

FFAR22L

20.18" x 17.38" x 19.0" (H x W x D)

Compact all-refrigerator with automatic defrost and front lock

Highlights:

Perfectly sized compact to fit tight spaces

Automatic defrost saves you time and maintenance

Factory-installed lock provides security you can depend on



Front-mounted lock	Keep contents secure with a key lock on the door
Automatic defrost	Reduced maintenance with auto defrost system
Door storage	Store items right on the door for easy access
Reversible door	User reversible door swing
Adjustable thermostat	Rear mounted to prevent accidental adjustments
Matching freezer available	Matches SUMMIT FS22L all-freezer
100% CFC	Environmentally friendly design without ozone-damaging chemicals

Specifications:

Height	20.18"
Width	17.38"
Depth	19.0"
Capacity	1.6 cu.ft.
Interior Height 1	16.5"
Interior Width 1	14.18"
Interior Depth 1	14.5"
Comp Step Height	6.75"
Comp Step Width	14.18"
Comp Step Depth	5.25"
Shipping Weight	55.0 lbs.
Weight	35.3 lbs.
US Electrical Safety	CSA
Energy Usage/Year	316.0 kWh/year
Voltage/Frequency	115 V AC/60 Hz
Canadian Electrical Safety	CSA
Amps	1.2
Reversible	Yes
Door Swing	RHD
Shelf Quantity	1
Shelf Type	Wire
Full Door Shelf Quantity	1
Half Door Shelf Quantity	1
Defrost Type	Automatic
Height to Hinge Cap	20.5"
Thermostat Type	Dial
High Side PSI	270.0
Freon Type	R134a
Level Legs Quantity	2
Freon Oz	1.67
Low Side PSI	103.0
Parts/Labor Warranty	1 Year
Compressor Warranty	5 Years

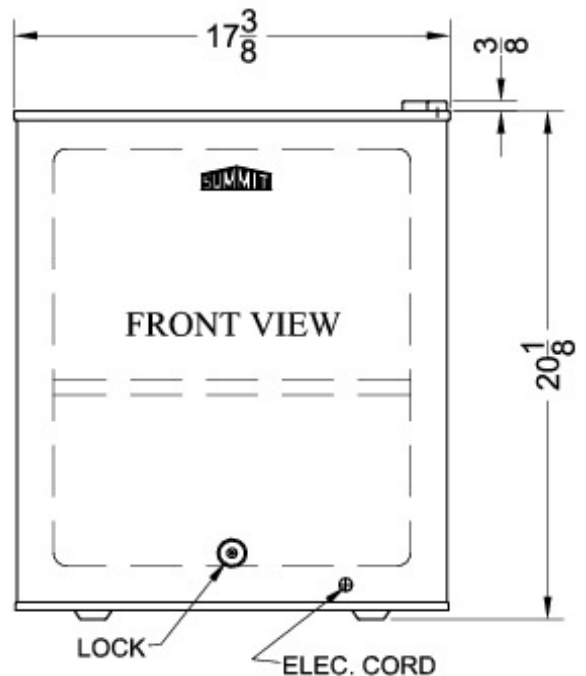
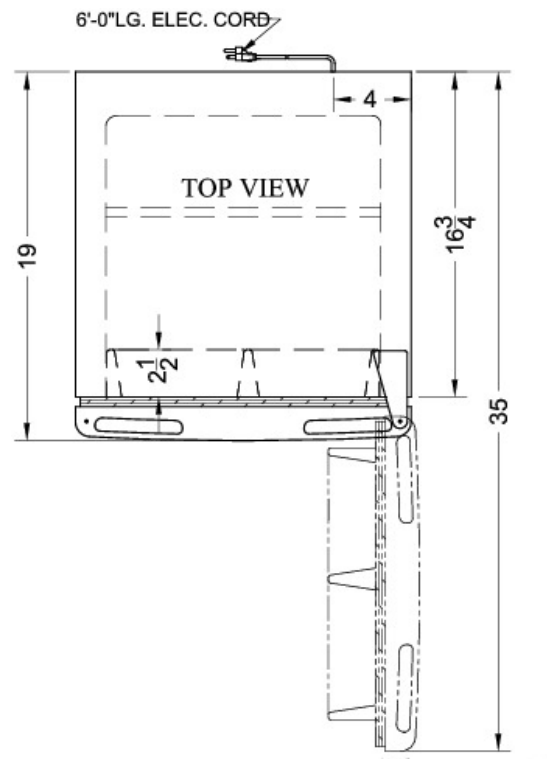

Summit Appliance Division, Felix Storch, Inc.
 770 Garrison Ave • Bronx, NY 10474
 Phone: 718-893-3900 • Fax: 718-842-3093
 Email: info@summitappliance.com