

HOTPOINT®

HTJ17CBT – Hotpoint® ENERGY STAR® 16.5 Cu. Ft. Top-Freezer Refrigerator

Front View

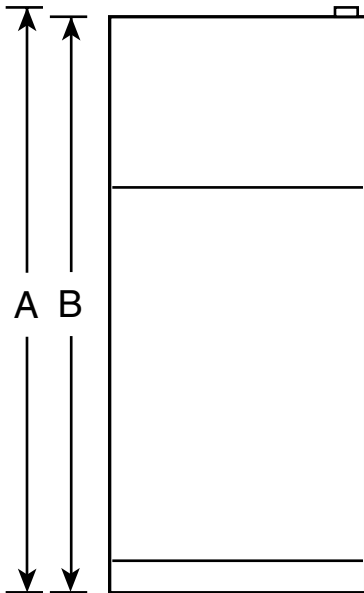

Top View

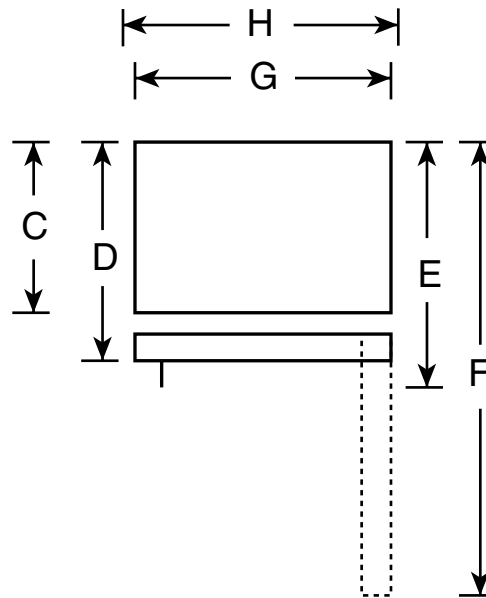

Overall Dimensions	Height to top of hinge (in.) A	64-3/4
	Height to top of case (in.) B	64-1/4
	Height to mid-freezer (in.)	54-3/8
	Case depth without door (in.) C	25-7/8
	Case depth less door handle (in.) D	29-1/8
	Case depth with door handle (in.) E	31
	Depth with fresh food door open 90° (in.) F	54-7/8
	Width (in.) G	28
Air Clearances	Width with door open 90° with door handle (in.) H	30-1/2
	Each side (in.)	3/4
	Top (in.)	1
	Back (in.)	1

Note: Before installing, consult installation instructions packed with product for current dimensional data.

Note: All Top-Freezer No-Frost Right-Hand Refrigerator Doors: As you face the front of the refrigerator, the handle is on your left and the hinges are on your right.

All Top-Freezer No-Frost Left-Hand Refrigerator Doors: As you face the front of the refrigerator, the handle is on your right and the hinges are on your left.



HOTPOINT®

HTJ17CBT – Hotpoint® ENERGY STAR® 16.5 Cu. Ft. Top-Freezer Refrigerator

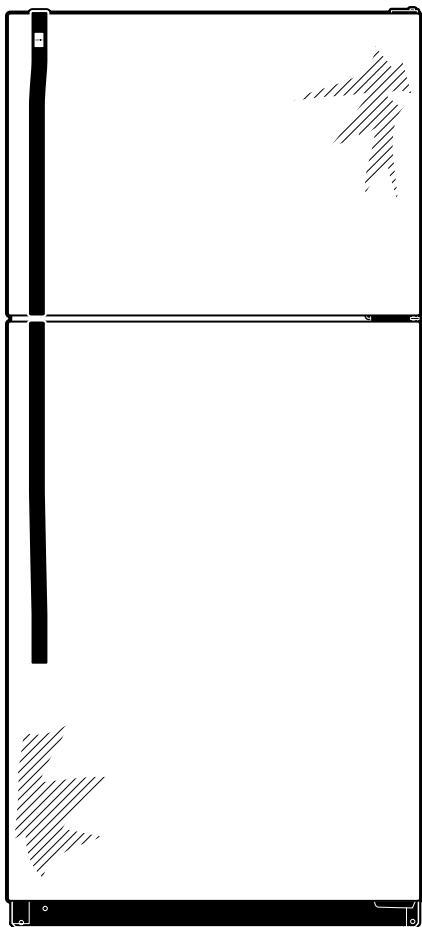

Features and Benefits

- Upfront temperature controls - Easy-to-use controls are located in an easy-to-reach position
- Adjustable wire shelves - Flexible shelving options can be arranged to handle a variety of foods
- Fixed gallon door shelves - Provides the ideal space for storing gallon containers in the door
- Crisper drawers - Provides the ideal environment for storing your fruits and vegetables
- Deluxe quiet design - Designed to reduce unnecessary sounds in the kitchen
- NeverClean™ condenser - Encased coils take the dirty work out of maintaining your refrigerator
- Model HTJ17CBTWW – Metallic Silver

