

CT959ST

GE Café™ 30" Built-In Double Convection Wall Oven

Dimensions and Installation Information (in inches)

KW Rating	
240V	7.6
208V	5.7
Breaker Size	
240V	40 Amps
208V	40 Amps

Most 30" Wall Cabinets can be used with this unit.

Note: These ovens are not approved for stackable installations. Cabinets installed adjacent to wall ovens must have an adhesion spec of at least a 194°F temperature rating.

Door handle protrudes 3" from door face. Cabinets and drawers on adjacent 45° and 90° walls should be placed to avoid interference with the handle.

Electric wall ovens are not approved for installation with a plug and receptacle. They must be hard wired in accordance with installation instructions.

Installation Information: Before installing, consult installation instructions packed with product for current dimensional data.

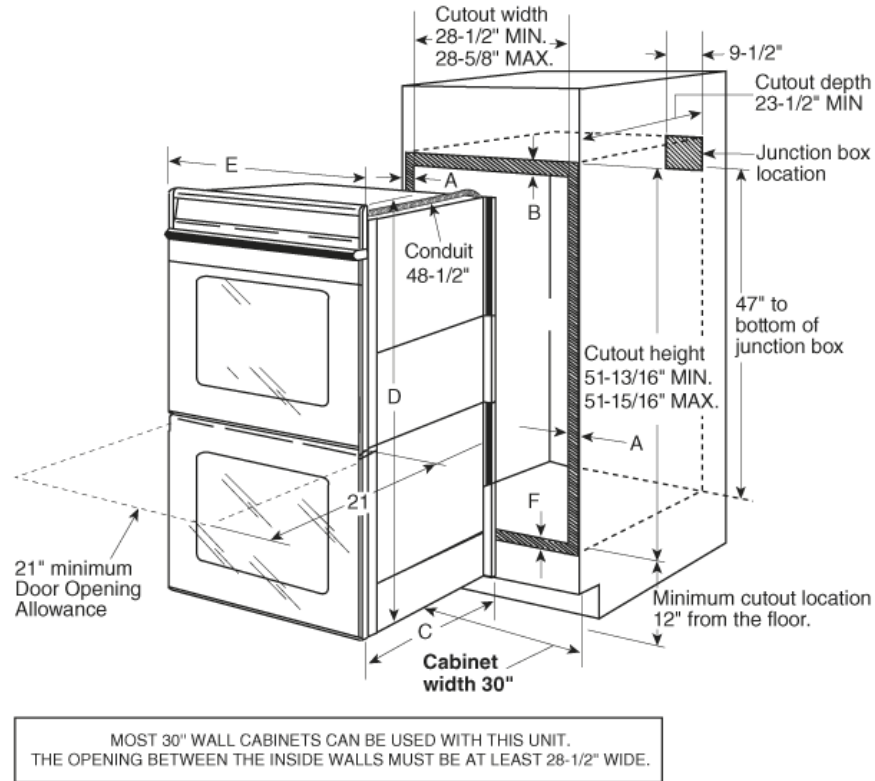

Cabinet	30"
A – Overlap of oven over side of edges of cutout	11/16"-3/4"
B – Overlap of oven at top of cutout	1"
Oven	
C – Overall depth with handle	27"
D – Overall height with trim	52-15/16"
Overall height without trim	52-7/16"
E – Overall width	29-11/16"
F – Overlap of oven at bottom of cutout	1-1/4"

For answers to your Monogram,® GE Profile™ or GE® appliance questions, visit our website at geappliances.com or call GE Answer Center® service, 800.626.2000.

Dimension and installation information are shown in inches.



Specification Created 5/11

220229

CT959ST

GE Café™ 30" Built-In Double Convection Wall Oven

Features and Benefits

- Glass touch controls - Smooth controls are easy to use and add a sophisticated style to the kitchen
- PreciseAir™ convection system (both ovens) - A reversing fan circulates heat and air for evenly browned and baked foods
- Convection Bake - This setting is optimal for baking casseroles or lasagnas, yeast breads, pies and pizzas with no need to turn the pan
- Convection Roast - Optimal for larger cuts of meat, this setting rotates the heat around all sides, sealing in the juices, producing rotisserie results at up to 25% faster than a conventional oven
- Heavy-duty roller racks - Racks provide easy access to items inside the oven by simplifying loading and unloading
- Black gloss oven interior - Black oven interior adds a stylish touch to any kitchen
- Model CT959STSS – Stainless steel

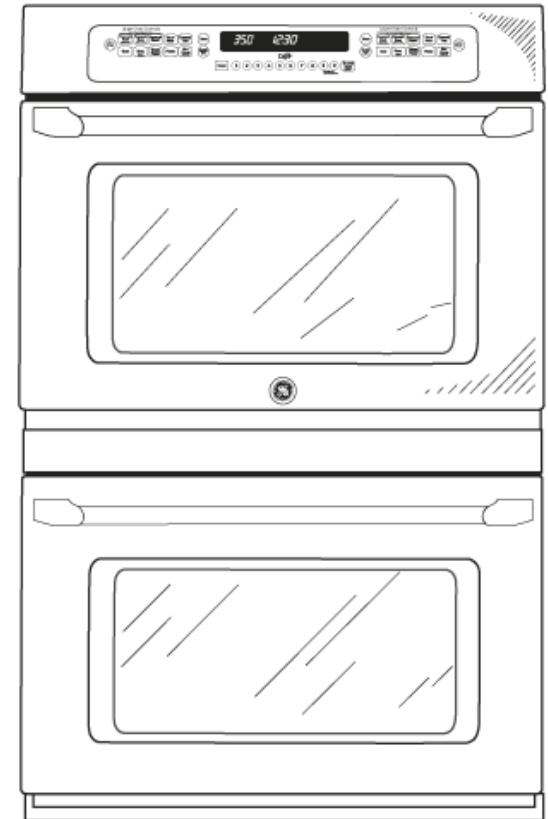

imagination at work