

OVEN CIRCUIT//CIRCUITO DE HORNO//CIRCUIT FOUR

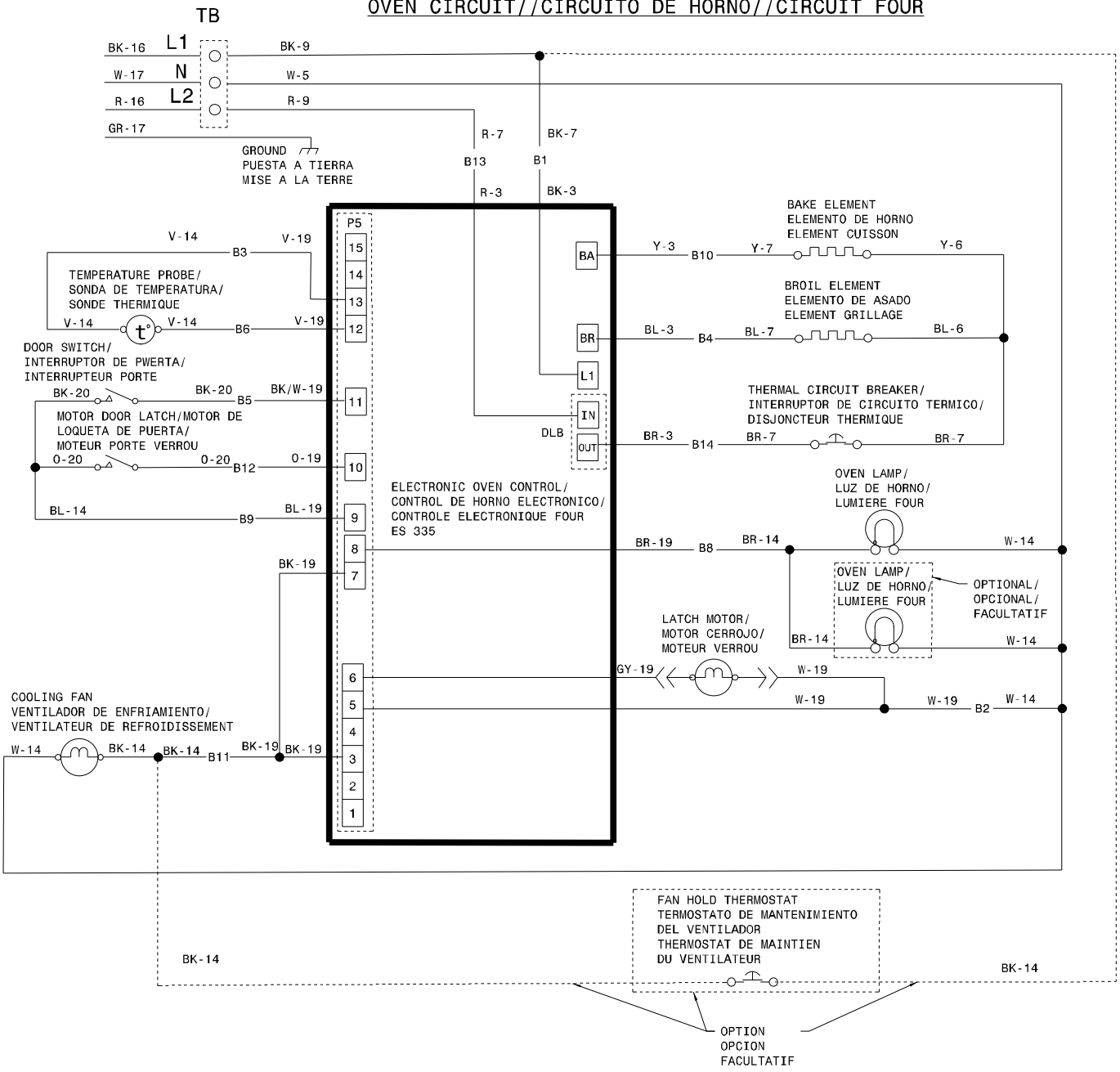

NOTE/NOTA/NOTE:
 COMPONENTS SHOWN ARE NOT NECESSARILY USED ON ALL MODELS.
 ESTOS COMPONENTES NO DEBEN DE APARECER EN TODOS LOS MODELOS.
 LES COMPOSANTES MONTREES NE SONT PAS NECESSAIREMENT UTILISEES SUR TOUS LES MODELES.

COLORS/CODIGOS DE COLORES/ CODE COULEUR

BK.	-BLACK/NEGRO/NOIR
G.	-GREEN/VERDE/VERT
W.	-WHITE/BLANCO/BLANC
R.	-RED/ROJO/ROUGE
O.	-ORANGE/NARANJA/ORANGE
Y.	-YELLOW/AMARILLO/JAUNE
BR.	-BROWN/MORENO/BRUN
BL.	-BLUE/AZUL/BLEU
GY.	-GRAY/GRIS/GRIS

CONNECTOR/ CONNECTOR/ CONNECTEUR A	CONNECTOR/ CONNECTOR/ CONNECTEUR B																														
<table border="1"> <tr><td>1</td><td>2</td><td>3</td></tr> <tr><td>4</td><td>5</td><td>6</td></tr> <tr><td>7</td><td>8</td><td>9</td></tr> <tr><td>10</td><td>11</td><td>12</td></tr> <tr><td>13</td><td>14</td><td>15</td></tr> </table>	1	2	3	4	5	6	7	8	9	10	11	12	13	14	15	<table border="1"> <tr><td>1</td><td>2</td><td>3</td></tr> <tr><td>4</td><td>5</td><td>6</td></tr> <tr><td>7</td><td>8</td><td>9</td></tr> <tr><td>10</td><td>11</td><td>12</td></tr> <tr><td>13</td><td>14</td><td>15</td></tr> </table>	1	2	3	4	5	6	7	8	9	10	11	12	13	14	15
1	2	3																													
4	5	6																													
7	8	9																													
10	11	12																													
13	14	15																													
1	2	3																													
4	5	6																													
7	8	9																													
10	11	12																													
13	14	15																													

CODE CODIGO	GAUGE MEDIDA	TEMP. °C	CSA	UL
1	18	125	CL1251	3173
2	16	125	CL1251	3173
3	14	125	CL1251	3173
4	12	125	CL1251	3173
5	18	150	EXL-150	3321
6	16	150	EXL-150	3321
7	14	150	EXL-150	3321
8	12	150	EXL-150	3321
9	10	150	EXL-150	3321
10	18	200	SEW-1	3122
11	16	200	SEW-1	3122
12	12	250		3252
13	16	250		3252
14	20	150	EXL-150	3321
15	8	150	EXL-150	3321
16	8	60		
17	10	60		
18	10	200	SEW-1	3122
19	20	125	CL1251	3173
20	20	200	SEW-1	3122
39	14	200	SEW-1	3122

CAUTION: DISCONNECT POWER BEFORE SERVICING UNIT.
 LABEL ALL WIRES PRIOR TO DISCONNECTION WHEN SERVICING CONTROLS.
 WIRINGS ERRORS CAN CAUSE IMPROPER AND DANGEROUS OPERATION.
 VERIFY PROPER OPERATION AFTER SERVICING.

ATENCIÓN: CORTAR LA CORRIENTE ANTES DE REALIZAR EL MANTENIMIENTO DEL ELECTRODOMESTICO.
 ETIQUETE TODOS LOS CABLES ANTES DE DESCONECTAR CUANDO HAGA EL SERVICIO A LOS CONTROLES.
 ERRORES AL VOLVER A ENSAMBLAR LOS CABLES PUEDE CAUSAR FALLAS U OPERACIONES PELIGROSAS.
 VERIFIQUE LA CORRECTA OPERACION DESPUES DEL SERVICIO.

ATTENTION: COUPEZ L'ALIMENTATION AVANT D'EFFECTUER LA REPARATION.
 IDENTIFIEZ TOUS LES FILS AVANT DE LES DEBRANCHER QUAND L'APPAREIL EST HORS SERVICE.
 LES ERREURS DE CONNECTION DE FILS PEUVENT CAUSER UN MAL FONCTIONNEMENT ET UN DANGER D'USAGE DE L'APPAREIL.
 VERIFIEZ LE BON FONCTIONNEMENT DE L'APPAREIL APRES LE SERVICE.

SURFACE-ELEMENT-CIRCUIT/CIRCUITO DE ELEMENTO DE SUPERFICIE
CIRCUIT DES ELEMENTS DE SURFACE
COIL/ESPIRAL/SPIRALE

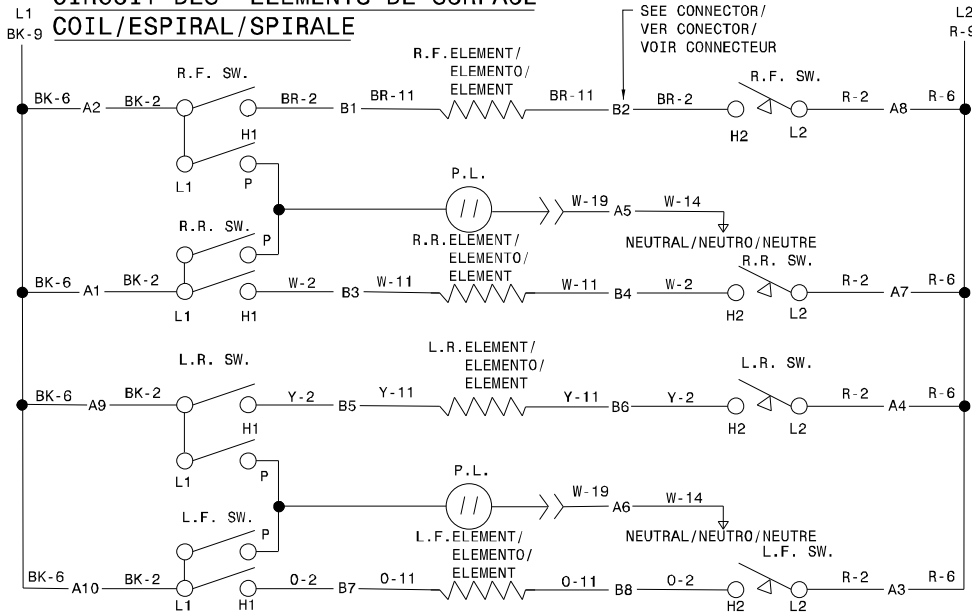

LEGEND/LEYENDA/LEGENDE

- SW. - SWITCH
INTERRUPTOR
INTERRUPTEUR
- P.L. - PILOT LIGHT
LAMPARA PILOTO
LAMPE TEMOIN
- R.F. - RIGHT FRONT
FRENTE DERECHO
AVANT DROIT
- R.R. - RIGHT REAR
TRASERO DERECHO
ARRIERE DROIT
- L.F. - LEFT FRONT
FRENTE IZQUIERDO
AVANT GAUCHE
- L.R. - LEFT REAR
TRASERO IZQUIERDO
ARRIERE GAUCHE
- H.S. - HOT SURFACE
SUPERFICIE CALIENTE
SURFACE CHAUDE
- LIM. - LIMITER/LIMITADOR/LIMITEUR

COLOR CODE/CODIGOS DE COLORES/CODE DE COULEUR

- BK. - BLACK/NEGRO/NOIR
- G. - GREEN/VERDE/VERT
- W. - WHITE/BLANCO/BLANC
- R. - RED/ROJO/ROUGE
- O. - ORANGE/NARANJA/ORANGE
- Y. - YELLOW/AMARILLO/JAUNE
- BR. - BROWN/CAFE/BRUN
- BL. - BLUE/AZUL/BLEU
- GY. - GRAY/GRIS/GRIS

SURFACE-ELEMENT-CIRCUIT/CIRCUITO DE ELEMENTO DE SUPERFICIE
CIRCUIT DES ELEMENTS DE SURFACE
GLASS COOKTOP/COBIERTA DE VIDRIO/TABLE DE CUISSON VITRIFIEE

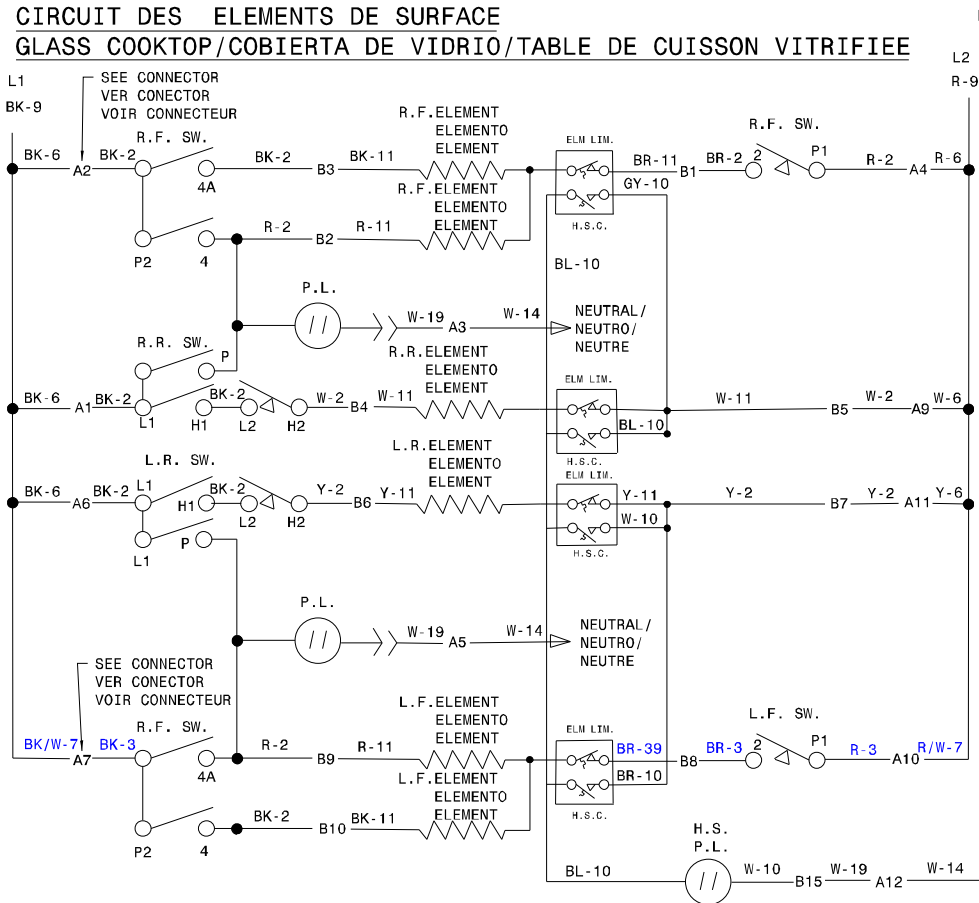

WIRE ALAMBRE FIL	GAUGE MEDIDA CALIBRE	TEMP. °C	CSA	UL
------------------	----------------------	----------	-----	----

1	18	125	CL1251	3173
2	16	125	CL1251	3173
3	14	125	CL1251	3173
4	12	125	CL1251	3173
5	18	150	EXL-150	3321
6	16	150	EXL-150	3321
7	14	150	EXL-150	3321
8	12	150	EXL-150	3321
9	10	150	EXL-150	3321
10	18	200	SEW-1	3122
11	16	200	SEW-1	3122
12	12	250		3252
13	16	250		3252
14	20	150	EXL-150	3321
15	8	150	EXL-150	3321
16	8	60		
17	10	60		
18	10	200	SEW-1	3122
19	20	125	CL1251	3173

LIMITER/LIMITOR/LIMITEUR
E.G.O./A.K.O.

LIMITER/LIMITOR/LIMITEUR
CERAMASPEED/EIKA

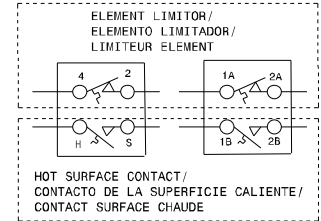

CONNECTOR/CONNECTOR/CONNECTEUR
B OR C

CONNECTOR/CONNECTOR/CONNECTEUR
A

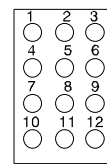
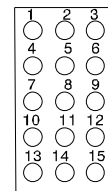

CAUTION: DISCONNECT POWER BEFORE SERVICING UNIT.
 LABEL ALL WIRES PRIOR TO DISCONNECTION WHEN SERVICING CONTROLS.
 WIRINGS ERRORS CAN CAUSE IMPROPER AND DANGEROUS OPERATION.
 VERIFY PROPER OPERATION AFTER SERVICING.

ATENCION: CORTAR LA CORRIENTE ANTES DE REALIZAR EL MANTENIMIENTO DEL ELECTRODOMESTICO.
 ETIQUETE TODOS LOS CABLES ANTES DE DESCONECTAR CUANDO HAGA EL SERVICIO A LOS CONTROLES.
 ERRORES AL VOLVER A ENSAMBLAR LOS CABLES PUEDE CAUSAR FALLAS U OPERACIONES PELIGROSAS.
 VERIFIQUE LA CORRECTA OPERACION DESPUES DEL SERVICIO.

ATTENTION: COUPEZ L'ALIMENTATION AVANT D'EFFECTUER LA REPARATION.
 IDENTIFIEZ TOUS LES FILS AVANT DE LES DEBRANCHER QUAND L'APPAREIL EST HORS SERVICE.
 LES ERREURS DE CONNECTION DE FILS PEUVENT CAUSER UN MAL FONCTIONNEMENT ET UN DANGER D'USAGE DE L'APPAREIL.
 VERIFIEZ LE BON FONCTIONNEMENT DE L'APPAREIL APRES LE SERVICE.