

**FF1410W**

69.5" x 26.0" x 26.0" (H x W x D)

Large capacity refrigerator-freezer with frost-free operation and unique 26" footprint

**Highlights:**

- Unique 26 inch footprint fits easily in tight kitchens
- Deluxe interior is fully featured for storage convenience
- True frost-free operation saves on maintenance by preventing icy buildup
- Generous storage capacity inside



Frost-free operation	No-frost convenience for reduced user maintenance
26" footprint	Perfectly sized for tight spaces
Large capacity	Over 12 cubic feet of storage inside
Factory reversible doors	Specify right or left hand door swing upon ordering
Interior light	Automatically illuminates when you open the door
Adjustable glass shelves	Rearrange your refrigerator space to accommodate all shapes and sizes or remove shelves for a simple clean-up
Fruit and vegetable crisper	Get the longest life and best taste out of produce by storing it in a convenient slide drawer
Door storage	Store large bottles right on the door for easy access
Adjustable thermostat	Control your food's temperature with ease and accuracy
Full freezer shelf	Allows you to better separate those TV dinners from your ice cream

## Specifications:

Height	69.5"
Width	26.0"
Depth	26.0"
Capacity	12.5 cu.ft.
Interior Height 1	40.0"
Interior Width 1	21.25"
Interior Depth 1	19.5"
Interior Height 2	16.0"
Interior Width 2	20.5"
Interior Depth 2	15.25"
Comp Step Height	8.0"
Comp Step Width	21.0"
Comp Step Depth	6.0"
Shipping Weight	190.0 lbs.
US Electrical Safety	UL
Voltage/Frequency	115 V AC/60 Hz
Energy Usage/Year	419.0 kWh/year
Canadian Electrical Safety	ULC
Reversible	Factory Reversible
Door Swing	RHD
Crisper Quantity	1
Shelf Quantity	2
Adjustable Shelf	true
Shelf Type	Glass
Crisper Cover Type	Glass
Crisper Finish	Transparent
Full Door Shelf Quantity	6
Defrost Type	Frost-Free
Depth with door at 90°	51.0"
Condensor Location	Rear of Unit
Light	true
Thermostat Type	Dial
Freon Type	R134a
Level Legs Quantity	2
Parts/Labor Warranty	1 Year
Compressor Warranty	5 Years

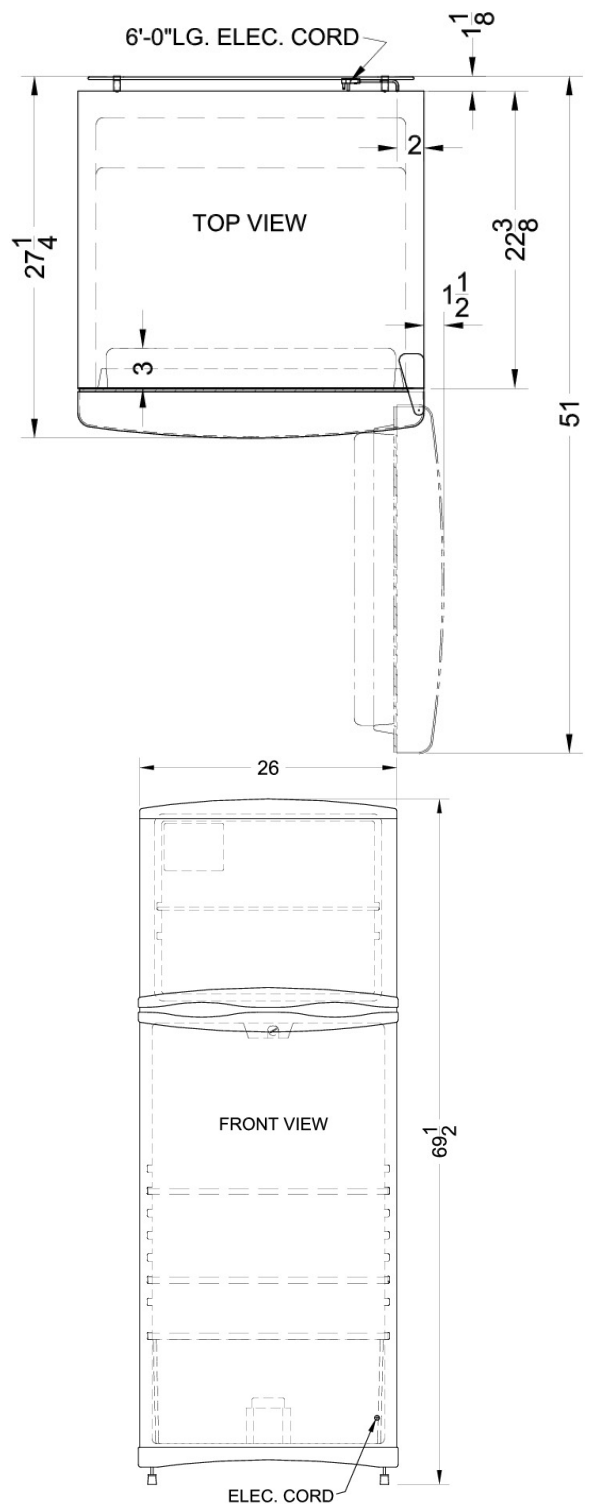

Summit Appliance Division, Felix Storch, Inc.  
 770 Garrison Ave • Bronx, NY 10474  
 Phone: 718-893-3900 • Fax: 718-842-3093  
 Email: info@summitappliance.com