

**FF41ESSS**

33.5" x 18.75" x 20.25" (H x W x D)

ENERGY STAR qualified auto defrost refrigerator-freezer, with a counter height white cabinet and reversible stainless steel door

**Highlights:**

- ENERGY STAR qualified with a more efficient system for lower energy use
- Compact size with a slim 19" width fits well in hotels and offices
- Door storage provides ample room for large bottles
- Reversible stainless steel door for convenient elegance



ENERGY STAR Qualified	Rated by the DOE to perform with more efficiency than federal standards require, saving your unit energy and you on higher utility costs and water waste
Automatic defrost	No-frost system simplifies maintenance in both refrigerator and freezer
Fully finished white cabinet	Allows the unit to be used freestanding
Stainless steel door	Durable elegance built to last
Reversible door	Keep your options flexible with a reversible door that is easy to switch when your arrangement changes
Adjustable thermostat	Manage the temperature with ease and accuracy
Crisper drawer	Get the longest life and best taste out of produce by storing greens in lower slide drawer
Door shelves	Store large bottles right on the door for easy access
Adjustable shelves	Rearrange the refrigerator space to fit any sized item or remove shelves for simple cleanup
Slim counter height dimensions	Less than 19 inches wide for easy placement in tight locations

## Specifications:

Height	33.5"
Width	18.75"
Depth	20.25"
Capacity	3.6 cu.ft.
Ext Depth with Handle	20.25"
Shipping Weight	95.0 lbs.
US Electrical Safety	UL
Energy Usage/Year	310.0 kWh/year
Voltage/Frequency	115 V AC/60 Hz
Canadian Electrical Safety	ULC
Amps	0.8
Reversible	Yes
Door Swing	RHD
Crisper Quantity	1
Shelf Quantity	2
Adjustable Shelf	true
Shelf Type	Wire
Crisper Cover Type	Glass
Crisper Finish	Transparent
Full Door Shelf Quantity	3
Defrost Type	Automatic
Depth with door at 90°	37.38"
Fan Type	Exterior
Thermostat Type	Dial
Condensor Location	Side of Unit
Freon Type	R134a
High Side PSI	235.0
Level Legs Quantity	2
Low Side PSI	140.0
Parts/Labor Warranty	1 Year
Compressor Warranty	5 Years

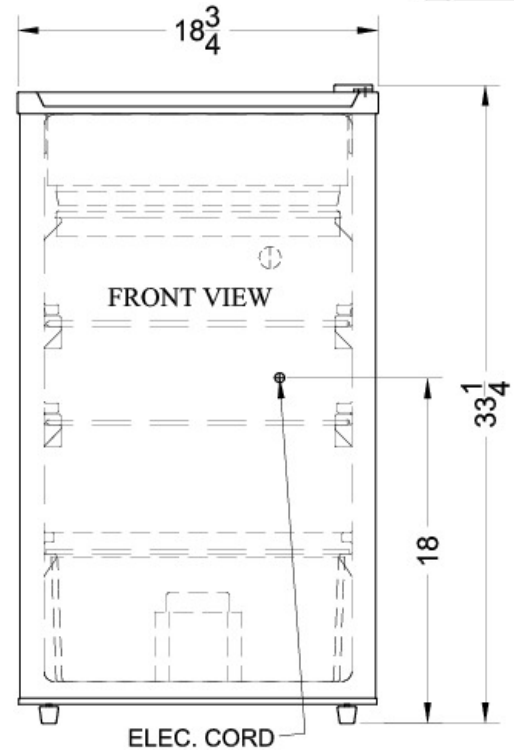
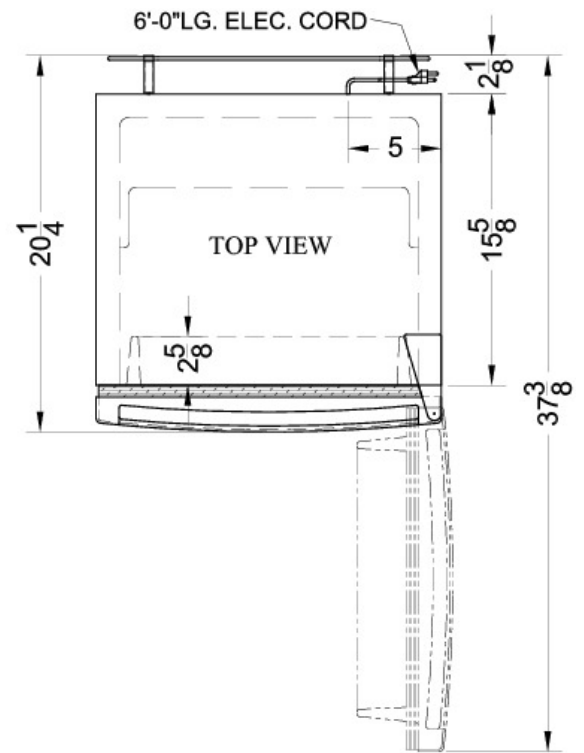

Summit Appliance Division, Felix Storch, Inc.  
 770 Garrison Ave • Bronx, NY 10474  
 Phone: 718-893-3900 • Fax: 718-842-3093  
 Email: [info@summitappliance.com](mailto:info@summitappliance.com)