

FF41SS

33.5" x 18.75" x 20.25" (H x W x D)

Compact refrigerator-freezer in slim 19 inch width, with auto defrost and stainless steel door

Highlights:

Save time and energy with automatic defrost

Fruit and vegetable crisper keeps your produce fresh and full-flavored

Door storage provides ample room for large bottles

Compact size fits great in offices and hotel rooms



Slim counterheight dimensions	Less than 20 inches wide to fit tight spots
Automatic defrost	Simplify appliance care by letting your refrigerator-freezer defrost itself
Adjustable thermostat	Control your food's temperature with ease and accuracy
Stainless steel wrapped door	Add a touch of luxury with stainless steel
Adjustable wire shelves	Rearrange your refrigerator space to accommodate all shapes and sizes or remove shelves for a simple clean-up
Fruit and vegetable crisper	Get the longest life and best taste out of produce by storing it in a convenient slide drawer
Door storage	Store large bottles right on the door for easy access
100% CFC free	Our North American-made refrigerator freezers are environmentally friendly because they do not run on ozone-damaging chemicals

Specifications:

Height	33.5"
Width	18.75"
Depth	20.25"
Capacity	3.6 cu.ft.
Ext Depth with Handle	20.25"
Shipping Weight	98.0 lbs.
US Electrical Safety	UL
Energy Usage/Year	371.0 kWh/year
Voltage/Frequency	115 V AC/60 Hz
Canadian Electrical Safety	ULC
Amps	0.8
Reversible	Yes
Door Swing	RHD
Crisper Quantity	1
Shelf Quantity	2
Adjustable Shelf	true
Shelf Type	Wire
Crisper Cover Type	Glass
Crisper Finish	Transparent
Full Door Shelf Quantity	3
Defrost Type	Automatic
Height to Hinge Cap	32.5"
Depth with door at 90°	37.38"
Thermostat Type	Dial
Fan Type	Exterior
Light	true
Condensor Location	Side of Unit
Freon Type	R134a
High Side PSI	235.0
Level Legs Quantity	2
Low Side PSI	140.0
Parts/Labor Warranty	1 Year
Compressor Warranty	5 Years

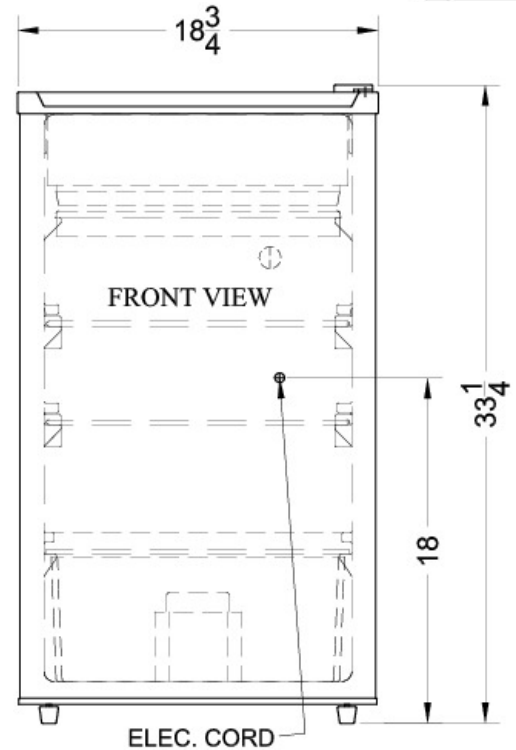
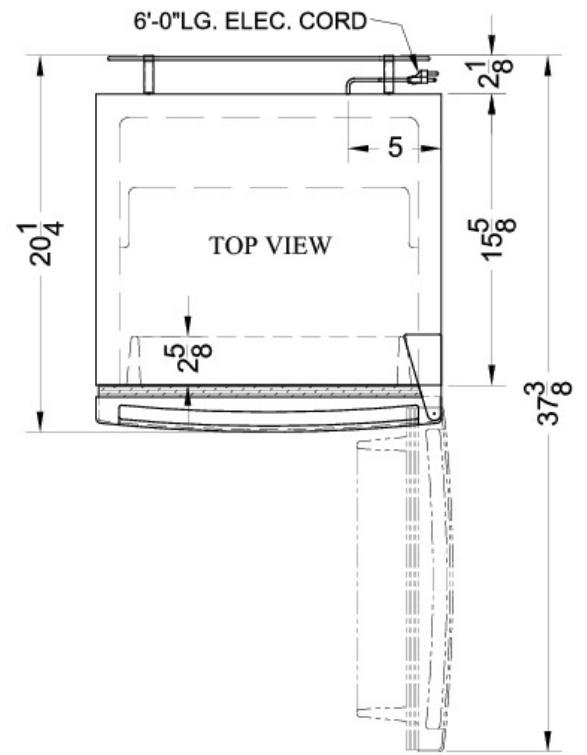

Summit Appliance Division, Felix Storch, Inc.
 770 Garrison Ave • Bronx, NY 10474
 Phone: 718-893-3900 • Fax: 718-842-3093
 Email: info@summitappliance.com