



SOU330X

classic

Single Oven, 76.2cm (30"),
Stainless Steel. Classic

EAN13: 8017709150242

- Finger-print proof stainless steel
- Ergonomic control knobs
- Touch control panel to access secondary menu
- Digital display
- Multifunction oven with 11 cooking modes
- True European Double Convection
- Fast Preheat Cycle (8 to 12 minutes)
- Min temp 86F
- Max temp 554F
- Automated oven switch-off when door is open
- Self cleaning
- Sabbath mode certified
- Control locks / Child Safety
- 6 Racks position
- 1 telescopic guide
- Oven capacity: 3.58 cu.ft.
- Usable oven capacity
- Interior dimensions: W 24" x H 16 1/8" x 16 5/16"
- Concealed bake element
- Broil element 3.5Kw
- Convection element with 1.3Kw per fan
- Voltage rating: 240/208V – 60Hz
- Connected load (nominal power):
- Amps @ 240/208V: 16.9/17.5
- Power supply location: center top

ACCESSORIES INCLUDED

- 1 Grid insert for tray
- 2 Grid top
- 1 Telescopic Guide
- 1 Enamelled Tray
- 1 Meat probe



Functions





Top and bottom heat:

This method is known as "conventional" cooking, and is suitable for dishes that require a more gentle heat, such as baking. The oven needs to be pre-heated to the required temperature, and is best suited for single items, such as large cakes. Best results are obtained by placing food in the centre of the oven.



European convection:

The combination of the fan and circular element around it, gives uniform heat distribution with no cold spots. This has benefits - no preheat if cook time is more than 20 minutes, no flavour transfer when cooking different foods the same time, less energy is needed, and it cooks at 10% quicker than a normal oven.



European convection with top and bottom heat:

The use of the fan with both elements allows food to be cooked quickly and effectively on a number of oven racks. Ideal for roasts that require thorough cooking. There is no transference of smells or flavours when using this function. This function offers a similar result to rotisserie, it moves the heat around the food, instead of moving the food itself, enabling any size or shape to be cooked, and not only items that will fit onto a rotisserie.



Circulaire with upper element:

The addition of the upper element adds extra heat at the top of the oven, where extra browning is required.



Intensive broil:

This allows rapid cooking and browning of foods. Best results can be obtained from using the top rack for small items, the lower racks for larger items, such as chops or sausages. Cooking using this method should be carried out with the door closed, unless instructed to do otherwise.



Pizza function:

The simultaneous operation of these three elements ensures an optimum cooking facility, ideal not only for pizza but also for cookies, quiches and flans.



Defrost:

The circulation of air at room temperature enables quicker thawing of frozen food, (without the use of any heat). Ideal for use prior to cooking of readymade dishes, or cream filled products etc.



Bread Proving:

Air at 104°F provides the perfect environment for proving yeast type dough mixes. Simply select the function and place dough in the oven for allotted time.



Pyrolytic:

Pyrolytic cleaning at 500°C destroys all the dirt deposits inside the oven. The process can be set from 1.5 hours to 3 hours, depending on the degree of dirt build up.



SOU330X

classic

multifunction thermo-ventilated
30"
antifingerprint st/steel

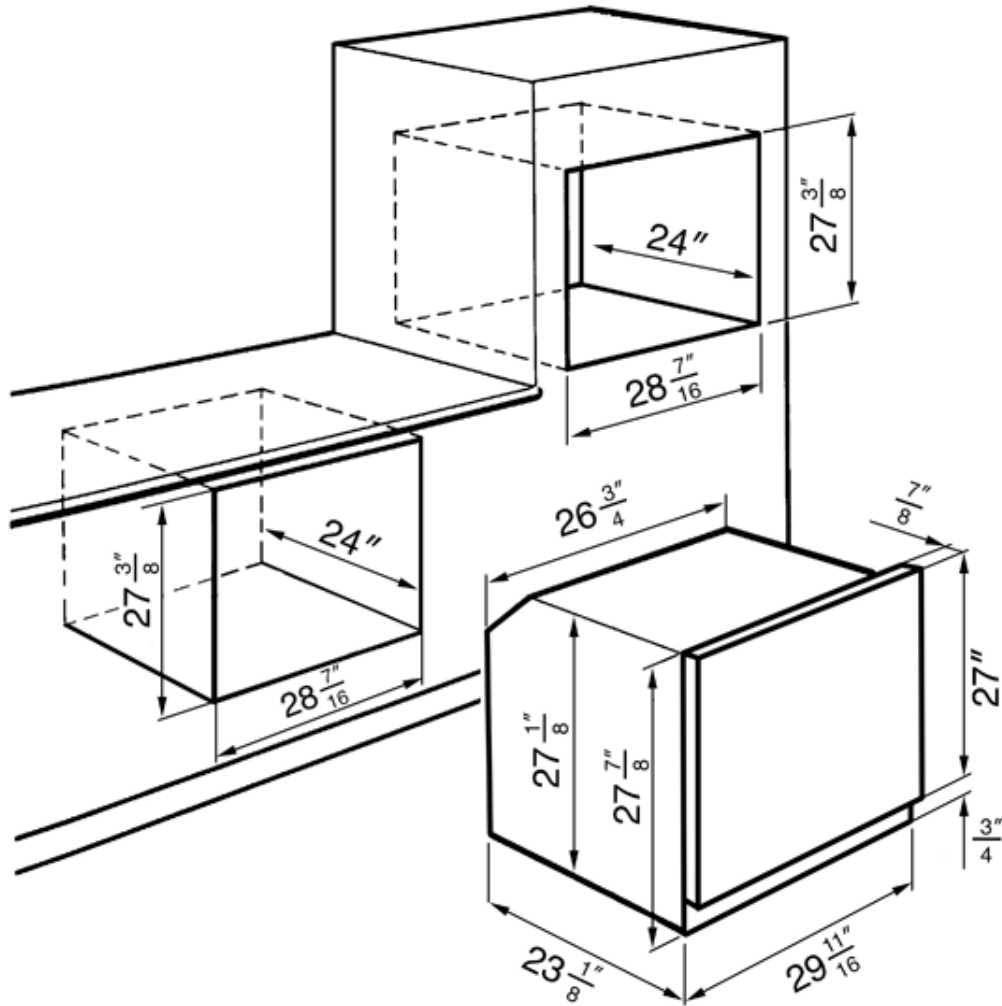

SMEG U.S.A. INC.
A&D BUILDING
150 EAST 58th STREET, 7th FLOOR
NEW YORK, NY, 10155
Tel. +1 212 265 5378
Fax +1 212 265 5945