

W757

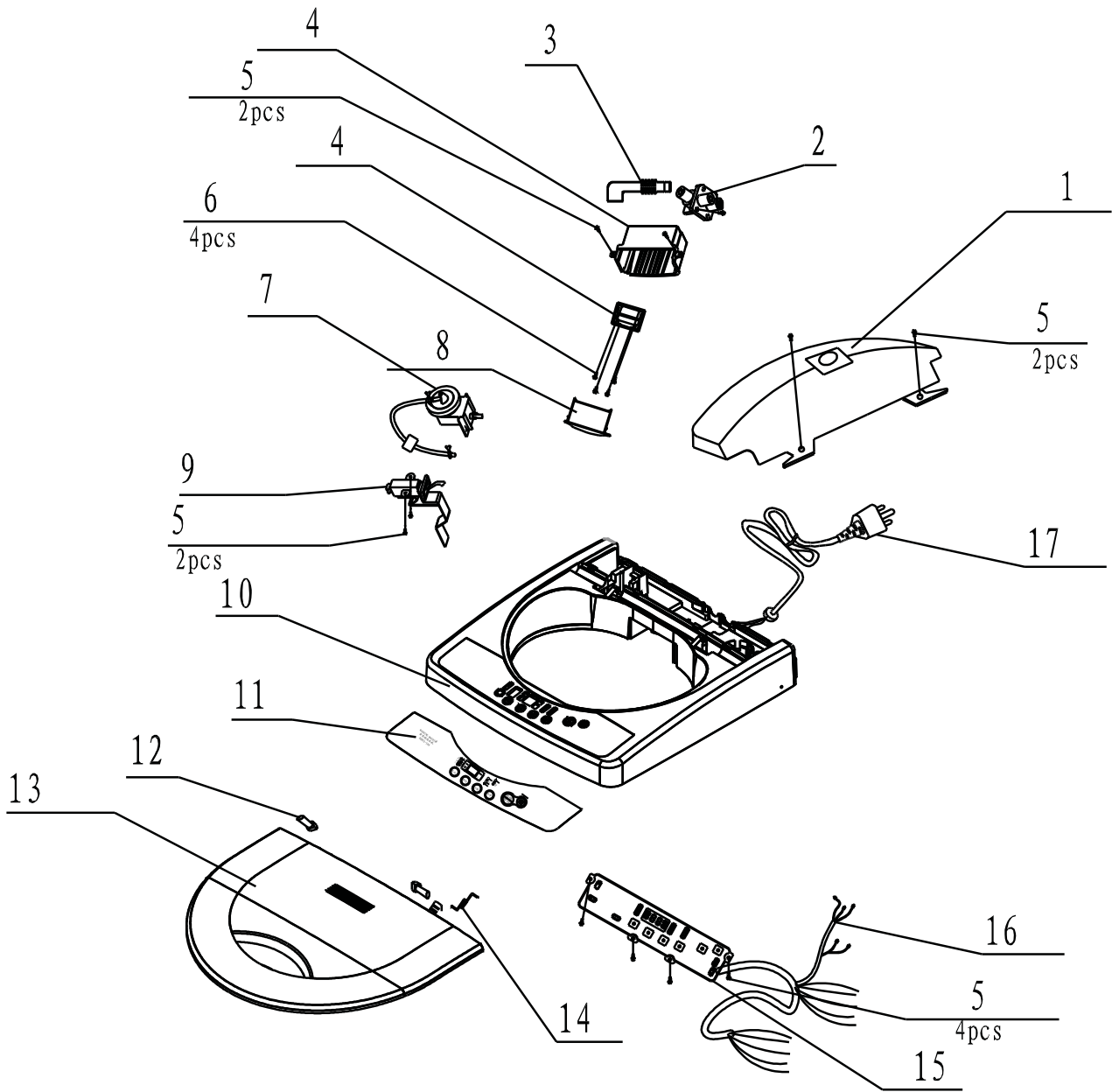

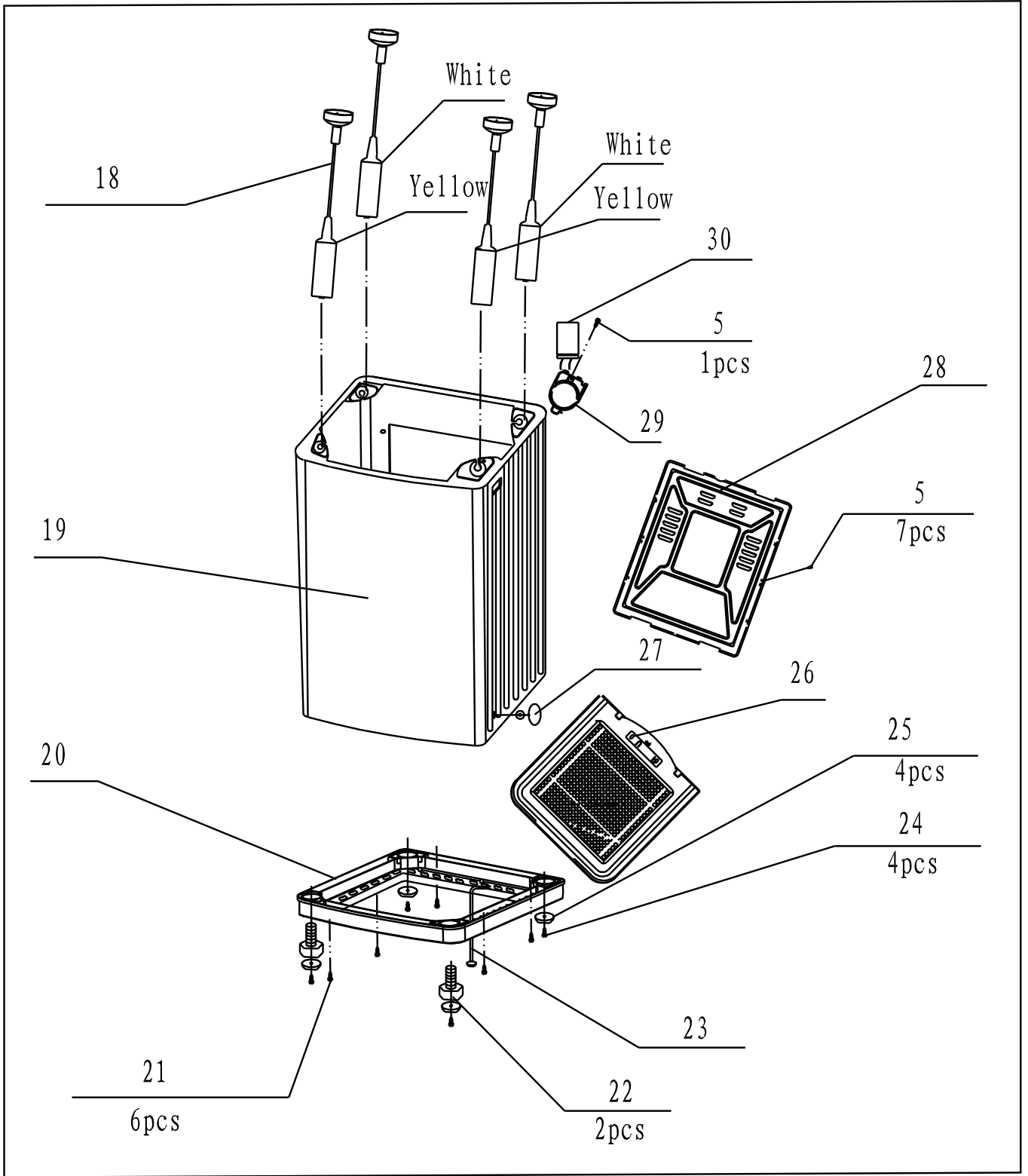

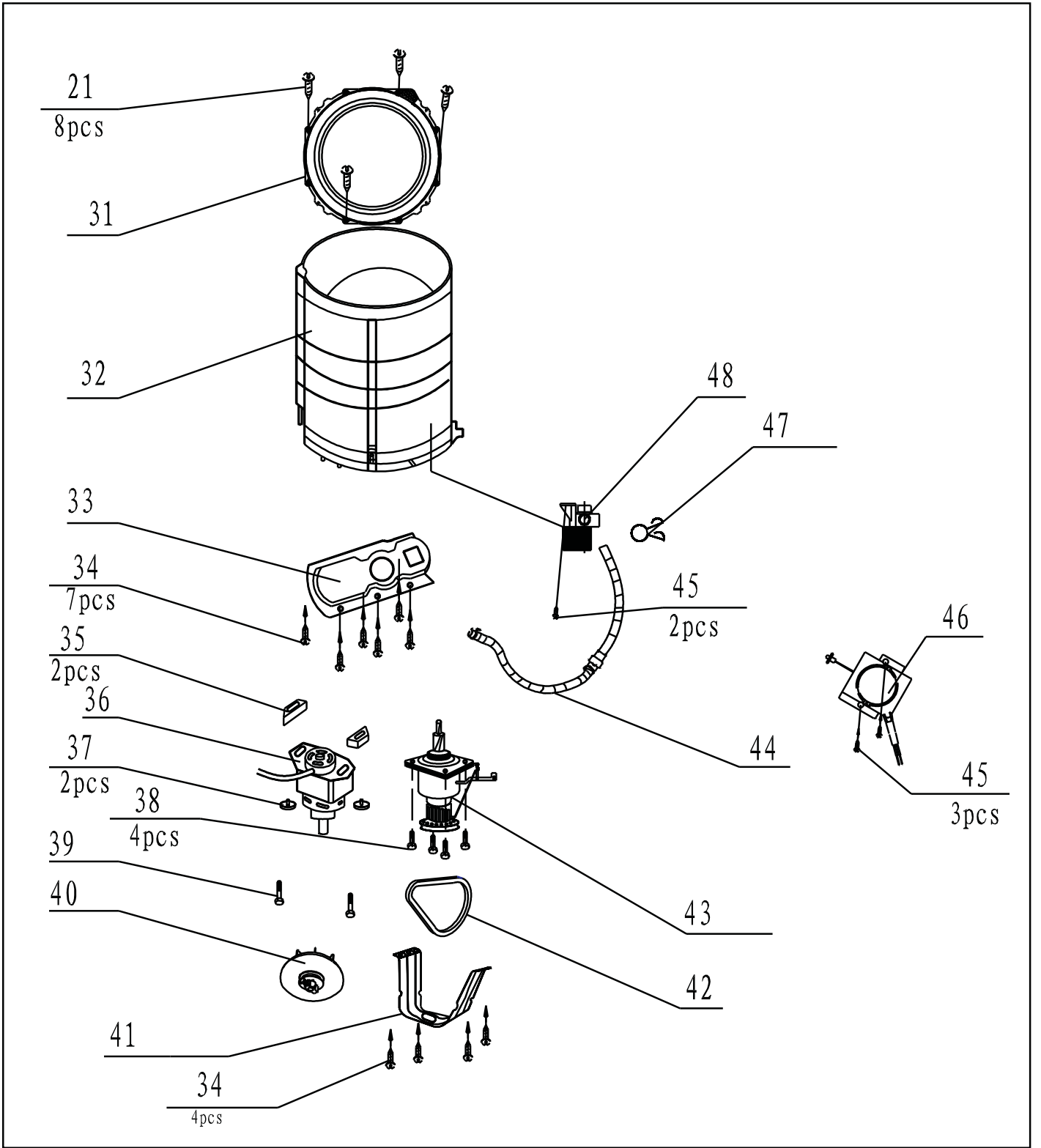

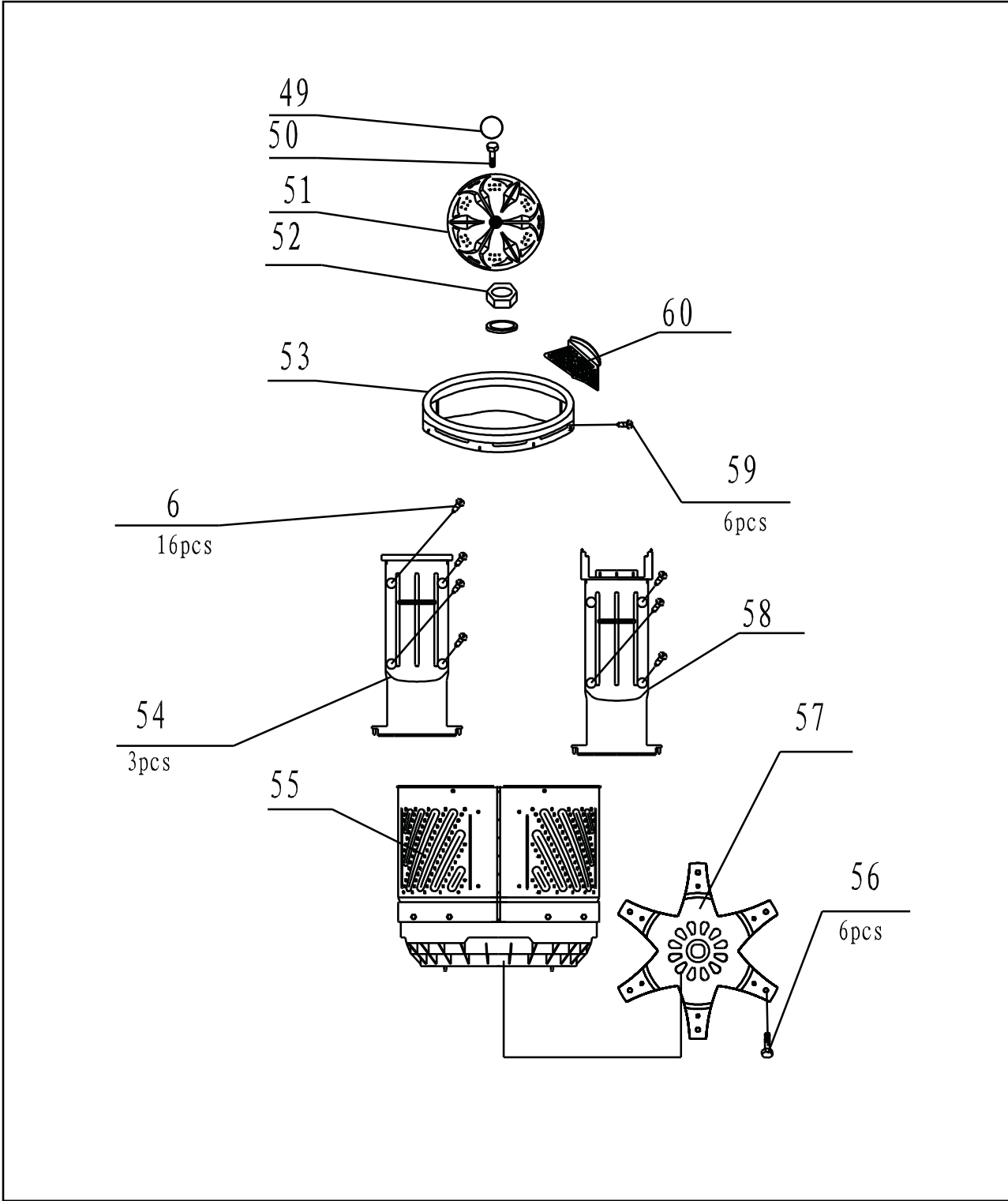

No	Part Code	Description
1	XQB50-168A-10-501	Back panel
2	XQB50-168-60-002	Water inlet valve
3	XQB50-168-10-511	Water inlet hose
4	XQB50-168-10-507	Water inlet bos
5	GB845-85	ST4.2x13 bolt
6	GB845-85	ST4.2x9.5 bolt
7	XQB50-188-60-006	Water lever switch
8	XQB50-168-10-506	Detergent box
9	XQB50-168-60-001	Safety switch
10	XQB50-168A-10-505	Control panel
11	XQB50-168-50-016	Decorative film
12	XQB50-168-10-509	Lid pin
13	XQB50-168G-10-502	Folding Lid
14	XQB50-168-40-001	Spring
15	XQB56-188-60-007	PCB board
16	XQB56-188-60-007	Internal wire
17	XQB50-168-60-009	Power Cord
18	XQB50-168-40-008	Suspension member assembly
19	XQB50-168-20-501	Cabinet
20	XQB50-168-30-501	Base
21	GB845-85	ST4.2x16 bolt
22	XQB50-168-30-502	Adjustable foot
23	XQB50-168-30-502	Level Adjustable foot
24	GB845-85	ST4.8x21 bolt
25	XQB50-168-50-007	Foot washer
26	XQB50-168-30-503	Mice proof plate
27		Level adjustable knob
28	XQB50-168-20-503	Back cover
29	XQB50-168-20-502	Capacitor clamp
30	XQB50-168-60-003	capacitor

31	XQB50-168-20-504	Outer tub ring
32	XQB50-168-20-505	Outer tub
33	XQB50-168-40-003	Mounting plate
34	GB9074.20-88	ST5.5x25 bolt
35	XQB50-168-20-515	Down mat for motor
36	XQB50-168-60-005	motor
37	XQB50-168-20-514	Up mat for motor
38	GB9074.17-88	M8x16 bolt
39	XQB50-168-40-021	Bolt for motor
40	XQB50-168-40-004	Motor pulley
41	XQB50-168-20-522	protective shelf
42		belt
43	XQB50-168-40-009	Clutch
44	XQB50-168-50-002	Drain hose
45	GB845-85	ST4.8x19 screw
46	XQB50-168-60-004	Drain motor
47	XQB50-168-40-005	φ 24 clip
48	XQB50-168-60-010	Drain Pump
49	XQB50-168-20-513	Cover of pulsator screw
50	GB9074.10-88	M6x20 bolt
51	XQB50-168-20-512	Pulsator
52	XQB50-168-40-017	M24x36
53	XQB50-168-20-506	Balance ring
54	XQB50-168-20-509	Waterfall Channel
55	XQB50-168-20-508	Drying tub
56	GB9074.20-88	ST4.8x22.5 bolt
57	XQB50-168-40-006	Tray
58	XQB50-168-20-510	Filter support channel
59	GB9074.20-88	ST4.8x16 bolt
60	XQB50-168-20-511	Filter