

# FRIGIDAIRE

affinity



## Front Load Dryers

FAQE701L B/W

6 Dry Cycles  
7.0 Cu. Ft. Electric



Optional SpaceWise® Pedestal Drawer Shown

### Product Dimensions

Height	36"
Width	27"
Depth	30-5/16"

### More Easy To Use Features

**SilentDesign™**  
for quiet operation.

**Moisture Sensor**

**Optional SpaceWise®  
Pedestal Drawer**

**Quick Dry Cycle - 25 Minutes**

**Reversible Door**

Available in:



Classic  
Black  
(B)



Classic  
White  
(W)

<sup>1</sup>Based on I.E.C. std. 60456 4th Edition for dryers 37" or less in height and 27" or less in width.

### Signature Features



#### Ultra-Capacity Dryer

The largest in its class<sup>1</sup>, so you can finish more laundry, even faster.



#### DrySense™ Technology

Dries your clothes more precisely, reducing wrinkles.

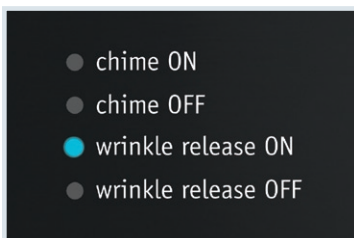

#### Wrinkle Release Technology



#### Express-Select® Controls

Easily select options with the touch of a button.

Features	
Total Capacity (Cu.Ft.)	7.0
Controls	Express-Select®
Dryer Drum Interior	Painted Steel
Interior Light	Yes
Door Trim	Color-Coordinated
Ready Steam™	
DrySense™ Technology	Yes
Wrinkle Release Technology	
TimeWise™ Technology	Yes
Moisture Sensor	Yes
Time Remaining Indicator	Yes
Cycle Status Lights	Yes
Cycle Signal	Chime
Cycle Signal "On/Off"	Yes
Cycle Signal Volume Control	Yes
Control Lock	Yes (Key Combination)
Start/Pause/Cancel Buttons	Yes
Energy Saver Option	
Delay Start	
Tumble Speed (RPM)	50
Reversible Door	Yes
Lint Screen	Yes
Sound Package	SilentDesign™
Adjustable Leveling Legs	Yes
Cycles	
Dry Cycles	6
Specialty Cycles	0
Options	
Temperature Selections	5
Dryness Level Selections	4
Timed Dry	15, 30, 60, 90
Optional Accessories	
Dryer Stacking Kit	PN # STACKIT4X
15" Frigidaire Affinity® Pedestal Drawers	
Classic Red (R)	
Classic Blue (N)	
Classic Silver (A)	
Classic Black (B)	(B) PN# CFPWD15B
Classic White (W)	(W) PN# CFPWD15W
Mobile Home Installation Kit	PN # 137067200
Drying Rack	PN # 137067300
Certifications	
NSF® Certified Sanitize	
Specifications	
Power Supply Connection Location	Right Bottom Rear
Voltage Rating	240V/60Hz/30A
Connected Load (kW Rating) @ 240 Volts	5.0
Amps @ 240 Volts	24
Heating Element @ 240 Volts (Watts)	4,500
Shipping Weight (Approx.)	140 Lbs.

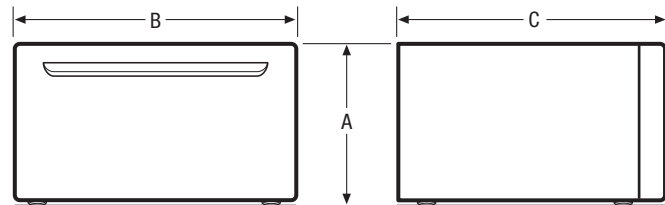
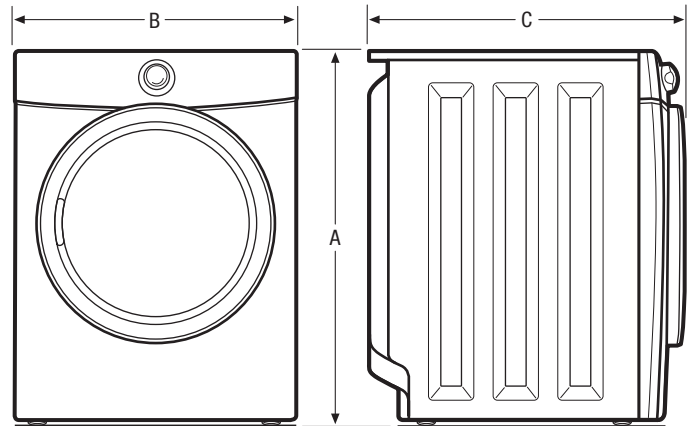

*NOTE: For planning purposes only. Always consult local and national electric and plumbing codes. Refer to Product Installation Guide for detailed installation instructions on the web at [frigidaire.com](http://frigidaire.com).*



Product Dimensions	
A - Height (Single)	36"
Height (Stacked)	71-1/2"
B - Width	27"
C - Depth	30-5/16"
Depth with Door Open 90°	51-7/16"
Pedestal Dimensions	
A - Height	15-1/4"
B - Width	27"
C - Depth	26-1/4"

Accessories information available on the web at [frigidaire.com](http://frigidaire.com)