

OVEN CIRCUIT // CIRCUITO DE HORNO

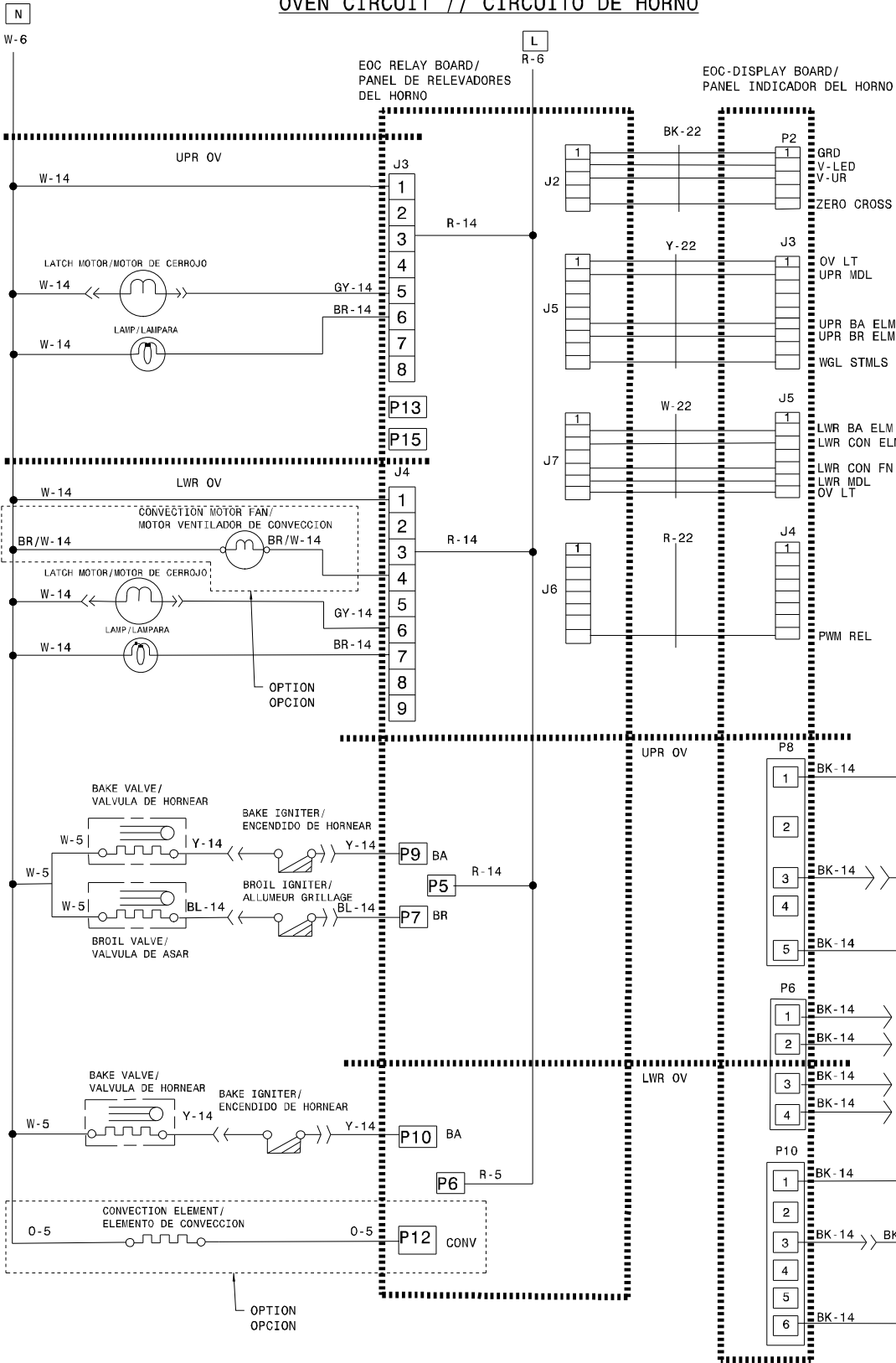

COLOR CODE/CODIGOS DE COLOR

- GY.-GREY/GRIS
- G.-GREEN/VERDE
- W.-WHITE/BLANCO
- R.-RED/ROJO
- O.-ORANGE/NARANJA
- Y.-YELLOW/AMARILLO
- BR.-BROWN/CAFE
- BL.-BLUE/AZUL
- BK.-BLACK/NEGRO
- V.-VIOLET/VIOLETA
- T.-TAN/CAFE CLARO
- BR/W.-BROWN STRIPES/WHITE // CAFE RAYAS BLANCO

LEGEND/LEYENDA

- THM.-THERMAL CIRCUIT BREAKER/INTERRUPTOR TERMICO
- UPR OV.-UPPER OVEN/HORNO SUPERIOR
- LWR OV.-LOWER OVEN /HORNO INFERIOR

CODE CODE	GAUGE CALIBRE	TEMP. °C	CSA	UL
1	18	125	CL1251	3173
2	16	125	CL1251	3173
3	14	125	CL1251	3173
4	12	125	CL1251	3173
5	18	150	EXL-150	3321
6	16	150	EXL-150	3321
7	14	150	EXL-150	3321
8	12	150	EXL-150	3321
9	10	150	EXL-150	3321
10	18	200	SEW-1	3122
11	16	200	SEW-1	3122
12	12	250		3252
13	16	250		3252
14	20	150	EXL-150	3321
15	8	150	EXL-150	3321
16	8	60		
17	10	60		
18	10	200	SEW-1	3122
19	20	125	CL1251	3173
20	20	200	SEW-1	3122
21	22	125	CL-1251	3173
22	22	150	EXL-150	3321
23	18	200		3573
24	20	450		5107
				5335
25	16	450		5107
34	16	200		3512

CAUTION:DISCONNECT POWER BEFORE SERVICING UNIT.
 LABEL ALL WIRES PRIOR TO DISCONNECTION WHEN SERVICING CONTROLS.
 WIRING ERRORS CAN CAUSE IMPROPER AND DANGEROUS OPERATION.
 VERIFY PROPER OPERATION AFTER SERVICING.

ATENCION:CORTAR LA CORRIENTE ANTES DE REALIZAR EL MANTENIMIENTO DEL ELECTRODOMESTICO.
 ETIQUETE TODOS LOS CABLES ANTES DE DESCONECTAR CUANDO HAGA EL SERVICIO A LOS CONTROLES.
 ERRORES AL VOLVER A ENSAMBLAR LOS CABLES PUEDE CAUSAR FALLAS U OPERACIONES PELIGROSAS.
 VERIFIQUE LA CORRECTA OPERACION DESPUES DEL SERVICIO.

COOKTOP CIRCUIT // CIRCUITO DE PLANCHA DE COCINAR

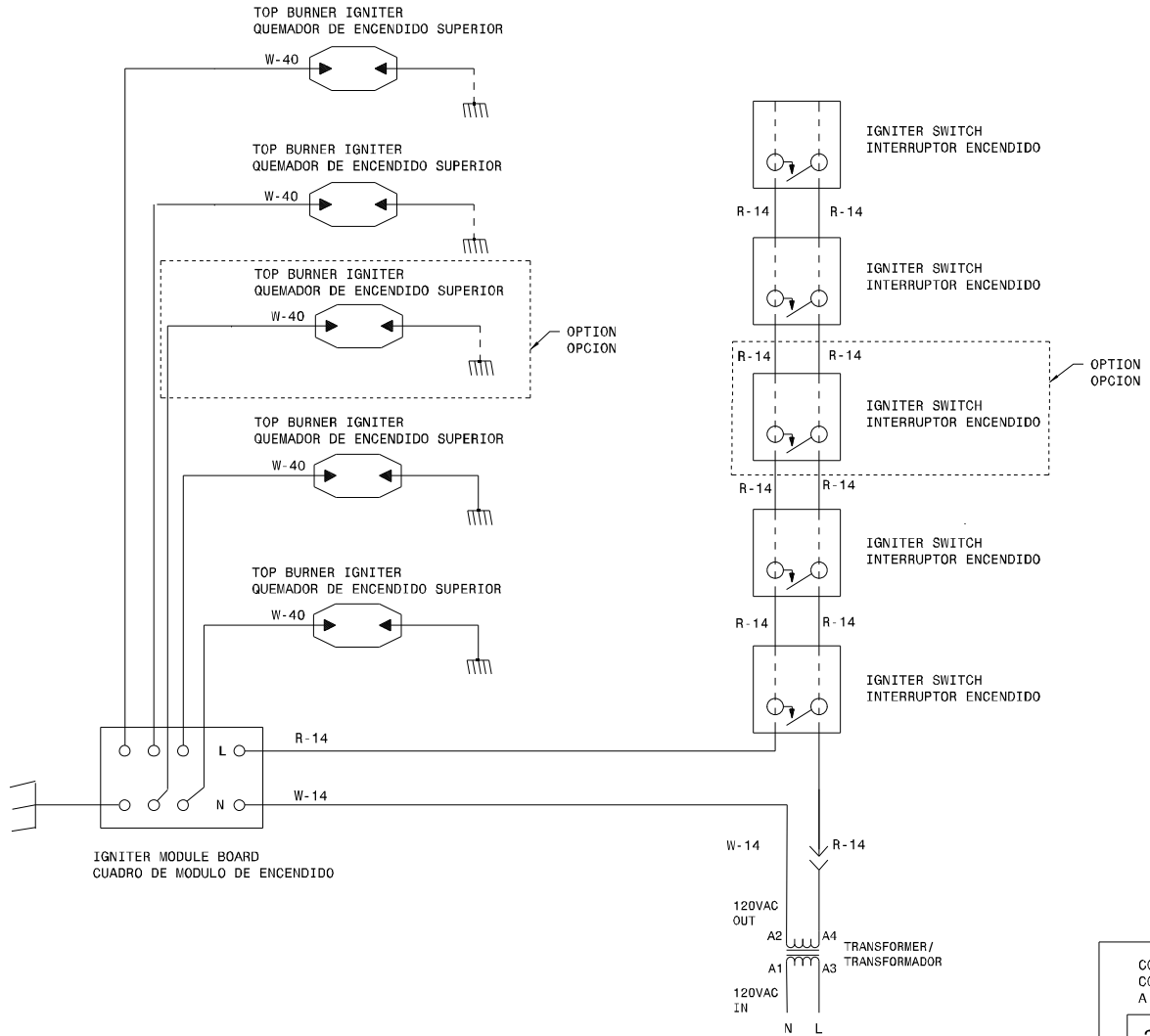

CONNECTOR
CONECTOR
A

2	4
1	3

CODE CODIGO	GAUGE MEDIDA	TEMP. °C	CSA	UL
1	18	125	CL1251	3173
2	16	125	CL1251	3173
3	14	125	CL1251	3173
4	12	125	CL1251	3173
5	18	150	EXL-150	3321
6	16	150	EXL-150	3321
7	14	150	EXL-150	3321
8	12	150	EXL-150	3321
9	10	150	EXL-150	3321
10	18	200	SEW-1	3122
11	16	200	SEW-1	3122
12	12	250		3252
13	16	250		3252
14	20	150	EXL-150	3321
15	8	150	EXL-150	3321
16	8	60		
17	10	60		
18	10	200	SEW-1	3122
19	20	125	CL1251	3173
20	20	200	SEW-1	3122
21	22	125		3266
22	22	150		10109
23	18	200		3573
34	16	200		3512
35	18	200		3512
37	14	200		3512
40	18	200	3204 OR/OU	10202
41	20	200		3512

CAUTION: DISCONNECT POWER BEFORE SERVICING UNIT.
 LABEL ALL WIRES PRIOR TO DISCONNECTION WHEN SERVICING CONTROLS.
 WIRINGS ERRORS CAN CAUSE IMPROPER AND DANGEROUS OPERATION.
 VERIFY PROPER OPERATION AFTER SERVICING.

ATENCION: CORTAR LA CORRIENTE ANTES DE REALIZAR EL MANTENIMIENTO DEL ELECTRODOMESTICO.
 ETIQUETE TODOS LOS CABLES ANTES DE DESCONECTAR CUANDO HAGA EL SERVICIO A LOS CONTROLES.
 ERRORES AL VOLVER A ENSAMBLAR LOS CABLES PUEDE CAUSAR FALLAS U OPERACIONES PELIGROSAS.
 VERIFIQUE LA CORRECTA OPERACION DESPUES DEL SERVICIO.