



48" Signature Series Refrigerator/Beverage Center Specification Sheet

Model Nos.
 HP48RB-B
 HP48RB-S



HP48RB

Features:

- Multi-zone, Multi-door undercounter refrigeration unit: Available in one or two temperature zones
- Designed with fully-integrated depth to allow flush fit with surrounding cabinetry (with 3/4" wood overlay)
- Zero-clearance hinging allows for abutment with surrounding cabinetry
- Perlick's exclusive Variable Speed Compressor
- Front-vented, forced-air refrigeration
- Industry Exclusive full-extension shelving
- Industry Exclusive stainless steel interior
- Two (2) year full warranty on complete unit – Additional four year limited warranty on the sealed refrigeration system
- Maintenance-free automatic defrost cycle
- Industry Exclusive Convertible Door Design allows all doors to be converted to wood overlay from stainless steel
- Low E, UV coated glass provides industry leading insulation and protection
- Doors lock available
- Interior digital display
- 12 cubic feet of capacity

48" refrigerator/beverage center features:

- Refrigerator zone features two (2) full-extension pullout shelves
- Beverage Center zone features two (2) full-extension wine racks and one (1) full extension shelf
- Refrigerator rated for both food and beverage storage
- Stainless steel ball bearing glides provide smooth movement of shelves
- Shelves are removable and adjustable to accommodate oversize (magnum) bottles
- Cabinet construction eliminates vibration transfer to reserve
- Refrigerator temperature 33 – 39 degrees F
- Beverage Center temperature 36 – 48 degrees F

Luxury YOU DESIRE.
INNOVATION YOU CAN'T LIVE WITHOUT.



8300 W. Good Hope Rd. • Milwaukee, WI 53223
1-800-558-5592 • Fax: (414) 353-7069 • www.Perlick.com

Perlick is committed to continuous improvement. Therefore, we reserve the right to change specifications without warning

Indoor Models	Refrigerator/Beverage Center
HP48RB-B	48" refrigerator/beverage center – built-in
HP48RB-S	48" refrigerator/beverage center – freestanding

Job _____
 Area _____
 Item No. _____
 Model No. _____

Beverage Center Door Options
1 – solid stainless door (Left or Right hinge)
2 – solid wood overlay door (Left or Right hinge)
3 – stainless glass door (Left or Right hinge)
4 – wood overlay glass door (Left or Right hinge)

Refrigerator Door Options
1 – solid stainless door (Left or Right hinge)
2 – solid wood overlay door (Left or Right hinge)
3 – stainless glass door (Left or Right hinge)
4 – wood overlay glass door (Left or Right hinge)
5 – solid stainless steel drawers (Left or Right hinge)
6 – solid wood overlay drawers (Left or Right hinge)

Overall Width: 47-7/8", 121.603 cm
Overall Height: 34-5/16", 87.154 cm
Overall Depth: 23-15/16", 60.801 cm
Capacity: 12 cubic ft.
Minimum Height Required: 34-3/8"
Door Swing Clearance: 24-25/32"
Electrical: 115V, 60 Hz., 1 phase AC, 2.3 amps
Plumbing: none required
Shipping Weight: 360 lbs.

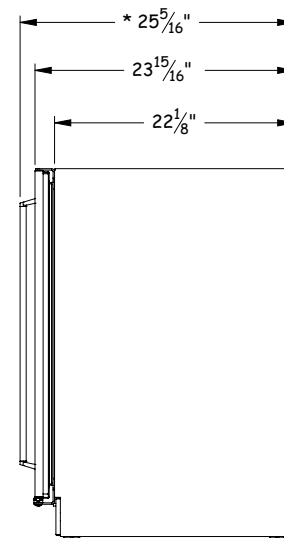
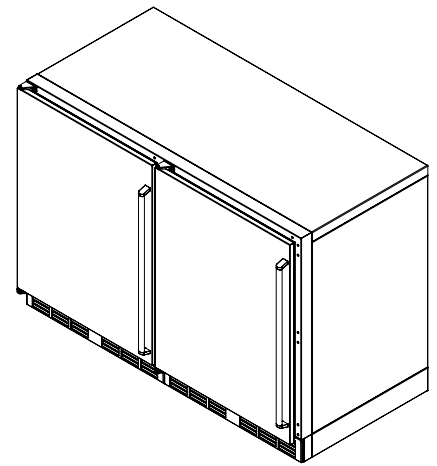
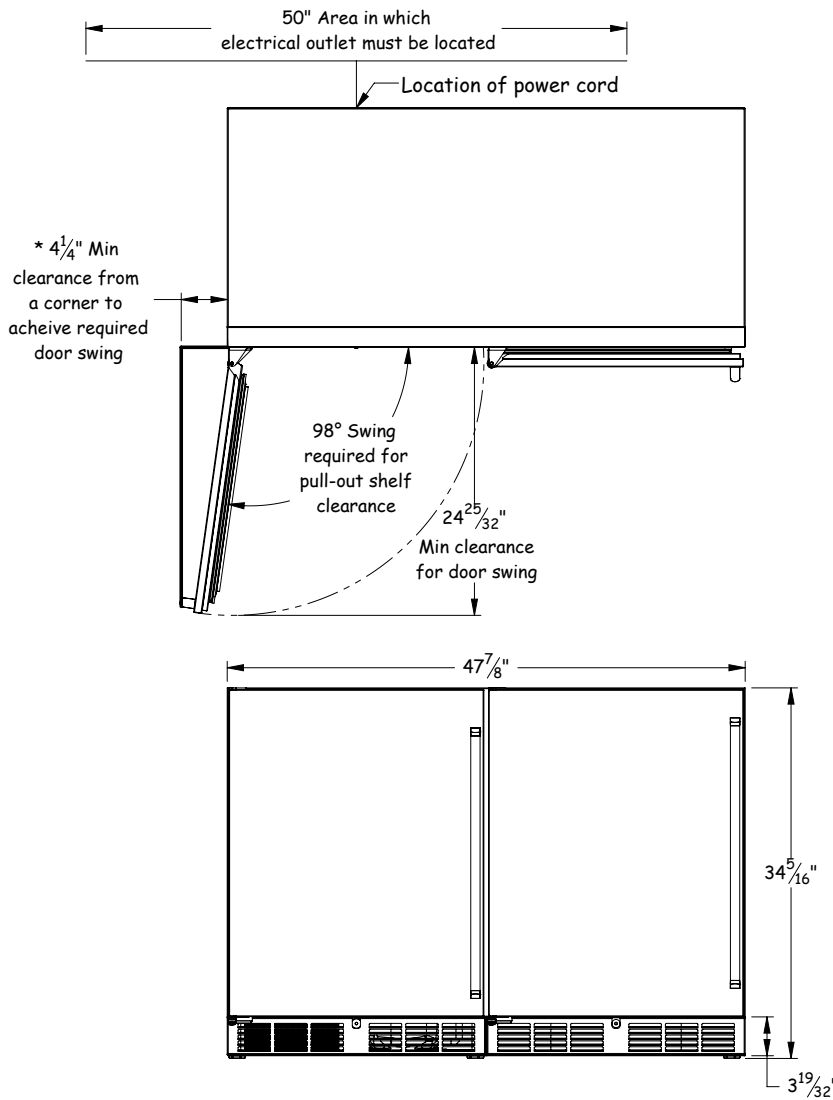

* - Values may change due to custom pull with a wood overlay door



8300 W. Good Hope Rd. • Milwaukee, WI 53223

1-800-558-5592 • Fax: (414) 353-7069 • www.Perlick.com

Perlick is committed to continuous improvement. Therefore, we reserve the right to change specifications without warning