

Maggiore



ISLAND HOOD

Maggiore offers a “minimalist” hood design that’s only 2.5” high and complements the many futuristic products and clean architectural lines often seen in today’s modern home. Maggiore features include a powerful 600 CFM blower, halogen lighting with 2 light intensities, dishwasher-safe anodized aluminum mesh filters and high-tech multi-functional LCD controls that deliver convenience and safety. Designed for standard ducted installation, Maggiore can also be installed as a recirculating system using the Recirculating Kit, available as an accessory.

FEATURES

• **Advanced Electronic Touch Controls**

State-of-the-art electronics deliver maximum user convenience and control. LCD function display with elegant blue illumination combined with low-profile, easy-to-clean touchpads is your interface with a multi-function control system, including...

- On/Off control
- Programmable timer and buzzer
- Four blower speeds
- Clock
- **HeatGuard™** automatically adjusts blower speed if heat exceeds 158°F for safety and convenience
- Two light intensities
- Filter Saturation Monitor detects excessive levels within both grease and charcoal filters



• **600 CFM 4-Speed Internal Blower**

• **4 Halogen Lamps** with two light intensities (12V 20W bulbs included)



Elica-Patented Stainless Steel Micro Hole Filter

Available as an optional upgrade
(see back for accessory details)

• **Dishwasher-Safe Anodized Aluminum Mesh Filter**

• **Telescopic Chimney Extension** – For ceiling heights 7' 2" to 9'11"

• **8" Round Duct Transition**

• **One-Way No Return Valve** eliminates outside air drafts.

elica

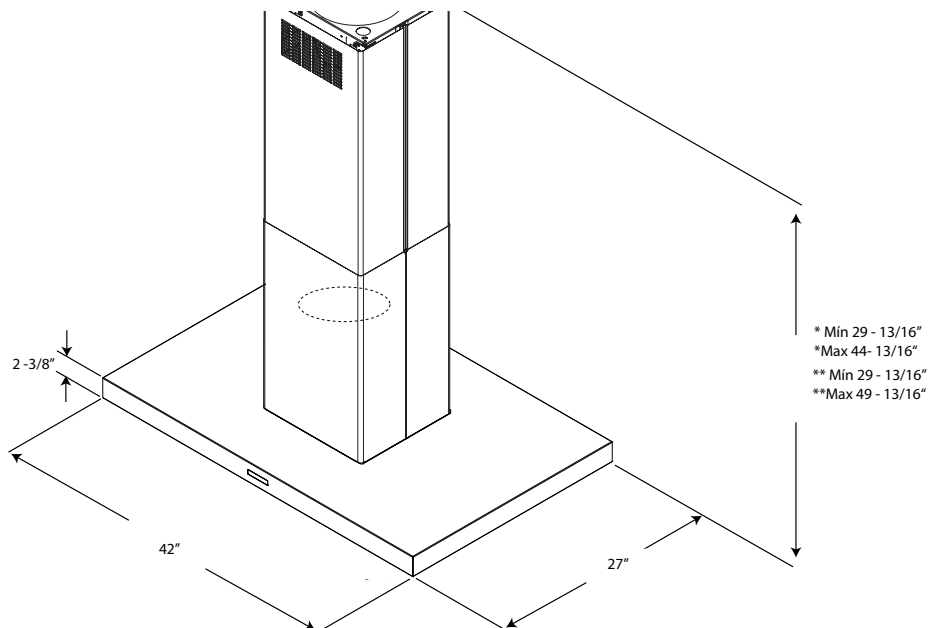

MODEL NUMBER	FINISH	DIMENSIONS			SHIPPING WEIGHT
		WIDTH	DEPTH	HEIGHT	
EMG642SS	Stainless Steel	42"	27"	2-3/8"	109 lbs

HOOD MOUNTING HEIGHT ABOVE COOKING SURFACE

GAS		ELECTRIC	
minimum	maximum	minimum	maximum
30"	34"	24"	30"

CHIMNEY HEIGHT (based on recommended mounting heights listed above)

DUCTED		RECIRCULATING	
Gas min./max.	Electric min./max.	Gas min./max.	Electric min./max.
8' - 9' 11"	7' 6" - 9' 7"	8' - 9' 6"	7' 2" - 9' 2"

BLOWER PERFORMANCE

SPEED LEVEL	AIRFLOW IN CFM (CUBIC FEET PER MINUTE)	SOUND LEVEL (IN SONES)
1	180	1.6
2	300	3.5
3	470	6.5
4	600	8.7

MAGGIORE ACCESSORIES

MODEL NUMBER	DESCRIPTION	SHIPPING WEIGHT
EXXRCK04	Recirculating Kit	8.8 lbs
EXXGFKMH	Stainless Steel Micro Hole Filter - One	5.5 lbs



ELECTRICAL:

AC Input: 120V - 60Hz, AC Power Max.: 530W at 4.4 Amps