

# Viking Use/Installation Guide



Viking Range Corporation

111 Front Street

Greenwood, Mississippi 38930 USA

(662) 455-1200

For product information,

call 1-888-VIKING1 (845-4641)

or visit the Viking Web site at

[vikingrange.com](http://vikingrange.com)



Undercounter/Freestanding Wine Cellars



**IMPORTANT - PLEASE READ AND FOLLOW**

- Before beginning, please read these instructions completely and carefully.
- Do not remove permanently affixed labels, warnings, or plates from the product. This may void the warranty.
- Please observe all local and national codes and ordinances.
- Please ensure that this product is properly grounded.
- The installer should leave these instructions with the consumer who should retain for local inspector's use and for future reference.

**A GFI shall be used if required by NFPA-70 (National Electric Code), federal/state/local laws, or local ordinances.**

- The required use of a GFI is normally related to the location of a receptacle with respect to any significant sources of water or moisture.
- Viking Range Corporation will NOT warranty any problems resulting from GFI outlets which are not installed properly or do not meet the requirements below.

**If the use of a GFI is required, it should be:**

- Of the receptacle type (breaker type or portable type NOT recommended)
- Used with permanent wiring only (temporary or portable wiring NOT recommended)
- On a dedicated circuit (no other receptacles, switches or loads in the circuit)
- Connected to a standard breaker of appropriate size (GFI breaker of the same size NOT recommended)
- Rated for Class A (5 mA +/- 1 mA trip current) as per UL 943 standard)
- In good condition and free from any loose-fitting gaskets (if applicable in outdoor situations)
- Protected from moisture (water, steam, high humidity) as much as reasonably possible

**⚠ WARNING**

To reduce the risk of fire, electric shock, or injury when using your unit, follow these basic precautions:

- Read all instructions before using the unit.
- Never allow children to operate, play with, or crawl inside the unit.
- Never clean unit parts with flammable fluids. The fumes can create a fire hazard or explosion.
- Always turn the power on/off switch (located behind the air grille on top right side) to the OFF position before attempting to change light bulbs, clean, or service the unit.

**FOR YOUR SAFETY**

DO NOT STORE OR USE GASOLINE OR OTHER FLAMMABLE VAPORS AND LIQUIDS IN THE VICINITY OF THIS OR ANY OTHER APPLIANCE. THE FUMES CAN CREATE A FIRE HAZARD OR EXPLOSION.

**It is your responsibility to be sure your wine cellar is:**

- located so the front is not blocked to restrict incoming or discharge air flow.
- properly leveled.
- located in a well ventilated area.
- connected to the proper kind of outlet, with the correct electric supply and grounding. A 115V, 60 Hz, 15 amp fused electrical supply is required. **NOTE: Time delay fuse or circuit breaker is recommended.**
- not used by anyone unable to operate it properly.
- used only for its intended purpose.
- properly maintained.

**•SAVE THESE INSTRUCTIONS•**

**PROPER DISPOSAL (OF OLD REFRIGERATION UNIT)**

**⚠ DANGER**

**RISK OF CHILD ENTRAPMENT**

Before You Throw Away Your Old Refrigeration Unit:

- Take off the doors.
- Leave the shelves in place so that children may not easily climb inside.

**IMPORTANT:** Child entrapment and suffocation are not problems of the past. Junked or abandoned refrigeration units are still dangerous... even if they will sit for "just a few days."

**IMPORTANT:**

Now that you have a new wine cellar, it is extremely important that you dispose of your old appliance in a way that minimizes the possibility that children will find it. There have been many cases in years past of children crawling inside junked and abandoned refrigeration units and becoming trapped or suffocated.

Contact your municipal waste disposal authority to find out the best and safest way to dispose of your old refrigeration unit.

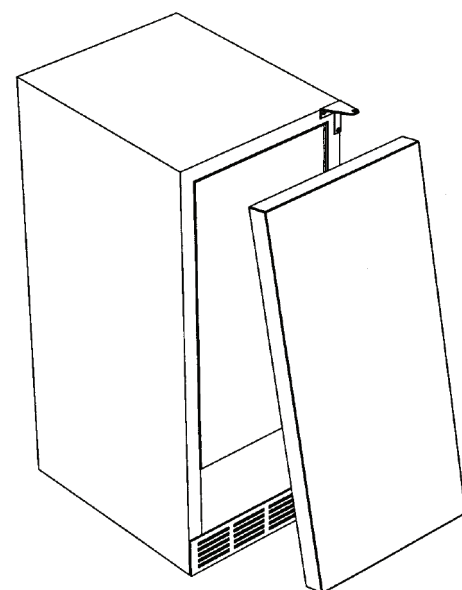

**GENERAL INFORMATION**

**Unpack**

1. Remove banding from bottom of carton. Lift carton up and off of the wine cellar
2. Remove all tape and packaging material from the outside and inside of the cabinet.
3. Keep all carton packaging until your wine cellar has been thoroughly inspected and found to be in good condition.

**AREA REQUIREMENTS**

1. Place unit so the front side will be completely unobstructed to provide proper air flow. The unit may be closed in on the top and three sides, but the front **MUST BE** unobstructed for air circulation and proper operation. Installation should be such that the cabinet can be moved for servicing if necessary.
2. Unit should be in a well ventilated area with temperature above 55°F (13°C) and below 110°F (43°C). Best results are obtained at temperatures between 65°F (18°C) and 80°F (27°C) for built-in models and 65°F (18°C) and 90°F (32°C) for freestanding models.
3. Provisions for electricity should be determined before placing unit in proper place.

**Units Certified for Outdoor Use - outdoor models contain a T after the base model number (ex. VUWC144T) and have a stainless steel outer cabinet.**

1. Place unit so the front side will be completely unobstructed to provide proper air flow. The unit may be closed in on the top and three sides, but the front **MUST BE** unobstructed for air circulation and proper operation. Installation should be such that the cabinet can be moved for servicing if necessary.
2. Unit should be in a well ventilated area with temperature above 40°F (4.4°C) and below 110°F (43°C). Best results are obtained at temperatures between 60°F (16°C) and 100°F (38°C).
3. Provisions for electricity should be determined before placing unit in proper place.

**UNDERCOUNTER CABINET CUTOUT**

**15" W. Models**

**24" W. Models**

	15" (38.1 cm)*	24" (61.0 cm)*
A	15" (38.1 cm)*	24" (61.0 cm)*
B	Min. 34-1/4" (87.0 cm) Max. 35" (88.9 cm)	Min. 34-1/4" (87.0 cm) Max. 35" (88.9 cm)
C	24" (61.0 cm)	24" (61.0 cm)

\*Add 1/4" (.64 cm) to cutout width if door is recessed between cabinets.

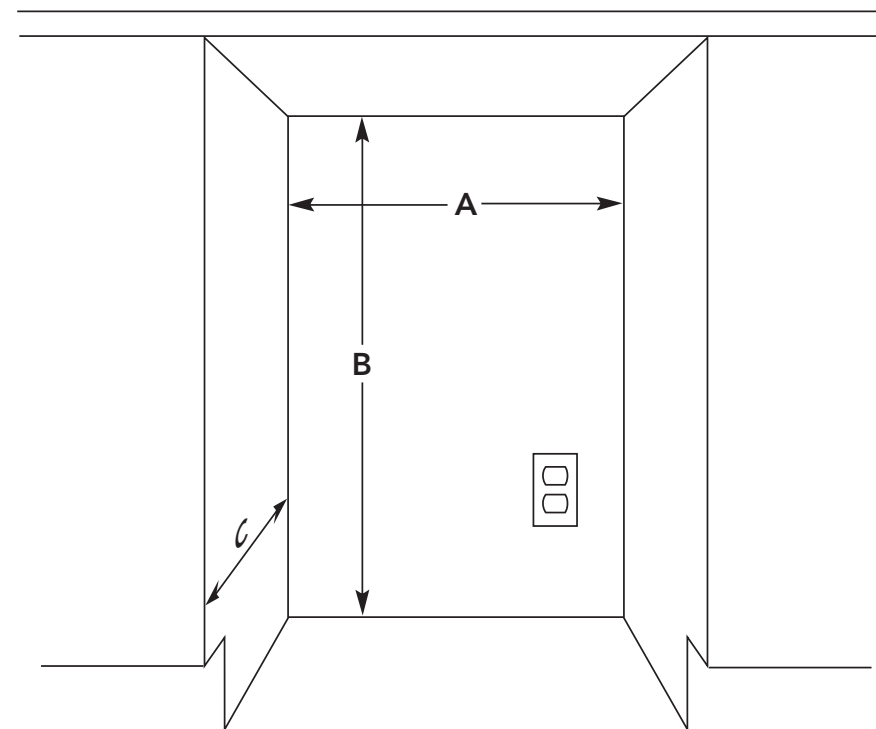

**SPECIFICATIONS/DIMENSIONS  
PROFESSIONAL - 15"W. Models**

**Basic Electric Data**

- 115 VAC/60 Hz
  - Maximum amps - 3.0
- Approximate Shipping Weight - 110 lbs. (49.5 kg)

**Dimensions  
VUWC 15"W.**

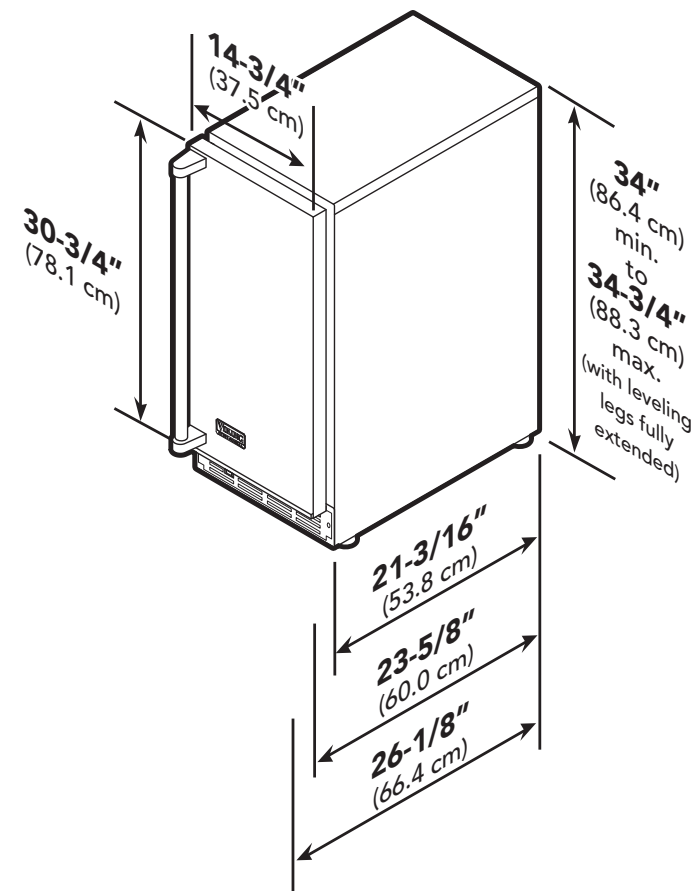

**Door Swing  
VUWC 15"W.**

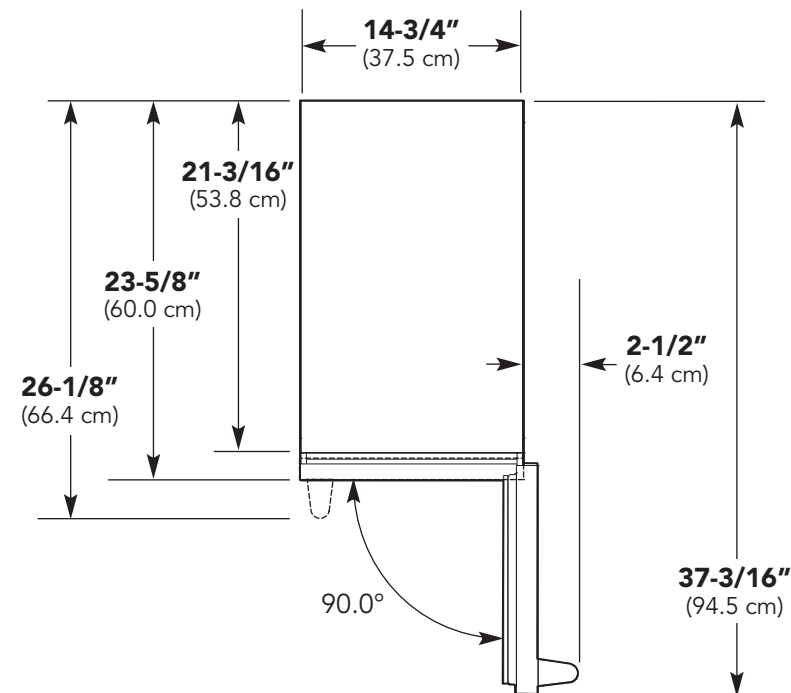

**SPECIFICATIONS/DIMENSIONS  
DESIGNER - 15"W. Models**

**Basic Electric Data**

- 115 VAC/60 Hz
  - Maximum amps - 3.0
- Approximate Shipping Weight - 110 lbs. (49.5 kg)

**Dimensions  
DUWC 15"W.**

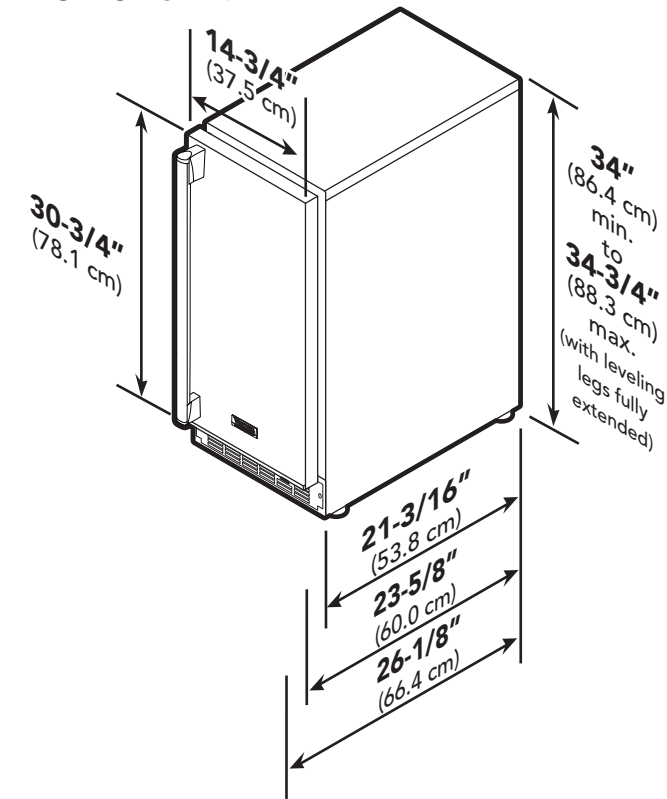

**Dimensions  
DFUW 15"W.**

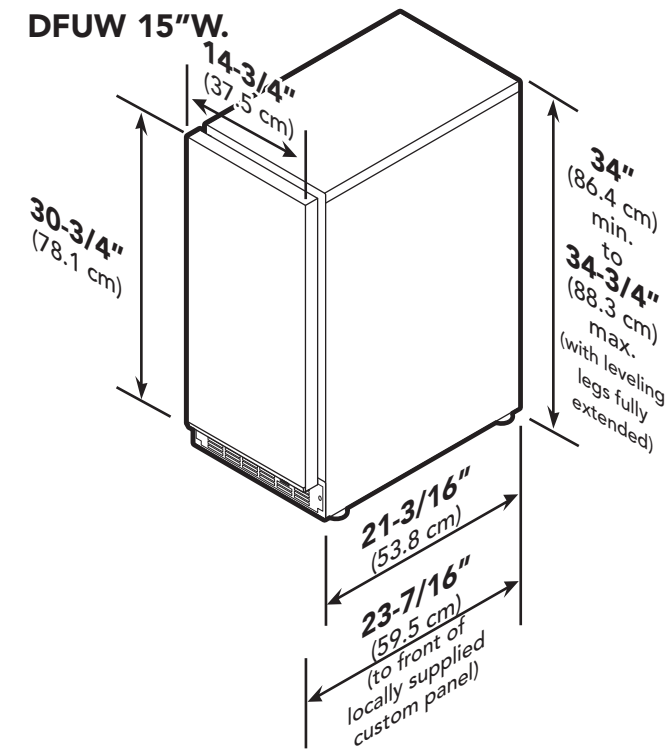

**Door Swing  
DUWC 15"W.**

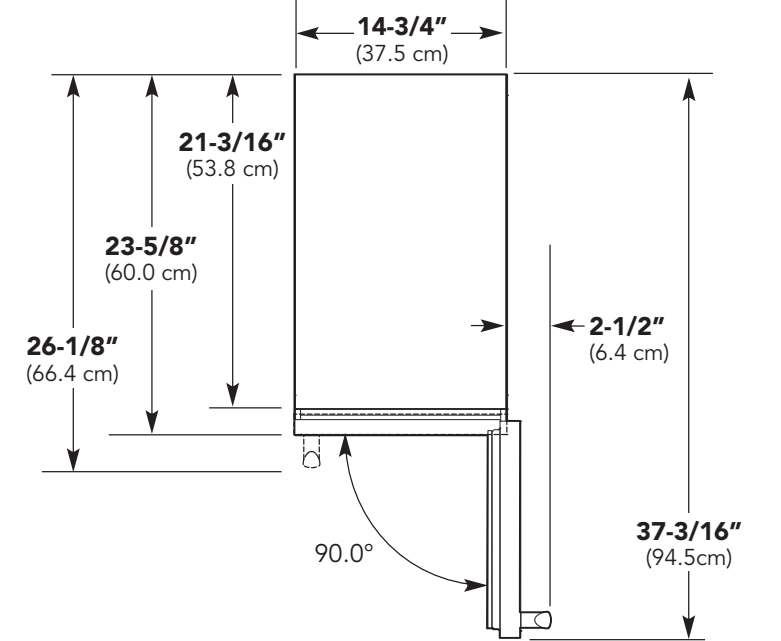

**Door Swing  
DFUW 15"W.**

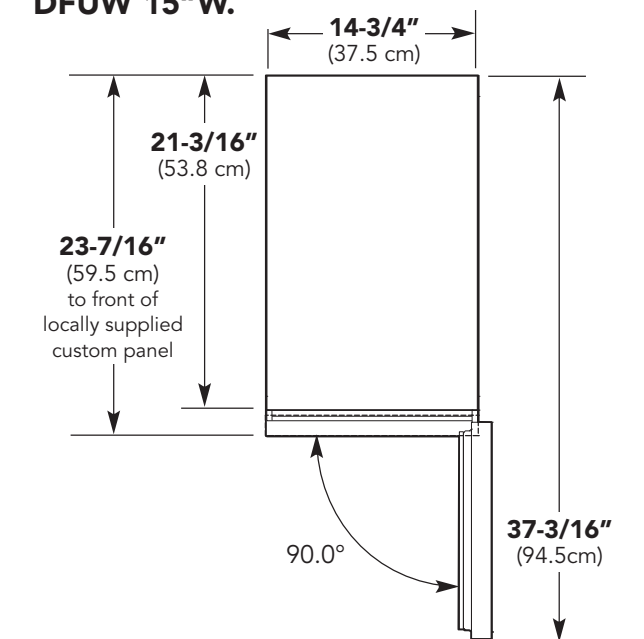

**SPECIFICATIONS/DIMENSIONS  
PROFESSIONAL - 24" W. Models**

**Basic Electric Data**

- 115 VAC/60 Hz
- Maximum amps - 3.3
- Approximate Shipping Weight  
Single Zone - 140 lbs. (63.2 kg)  
Dual Zone - 170 lbs. (76.5 kg)

**Dimensions VUWC 24"W. - Single Zone**

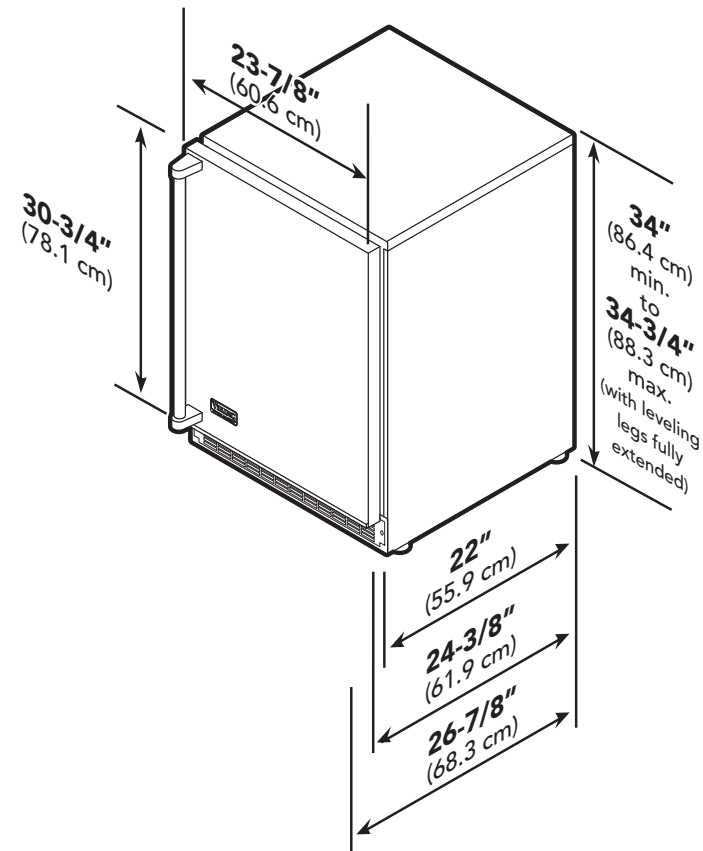

**Dimensions VUWC 24"W. - Dual Zone**

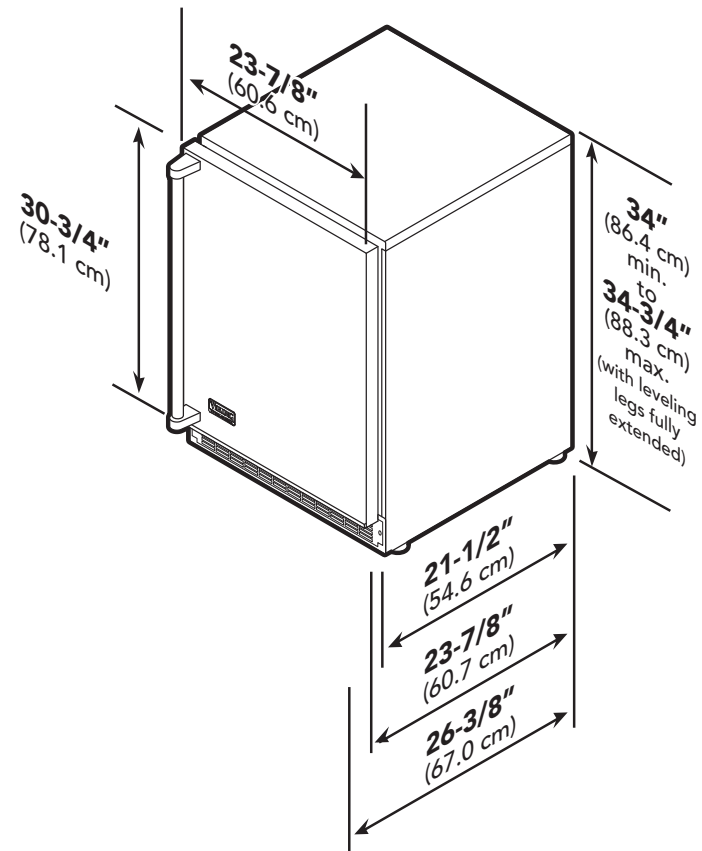

**Door Swing VUWC 24"W. - Single Zone**

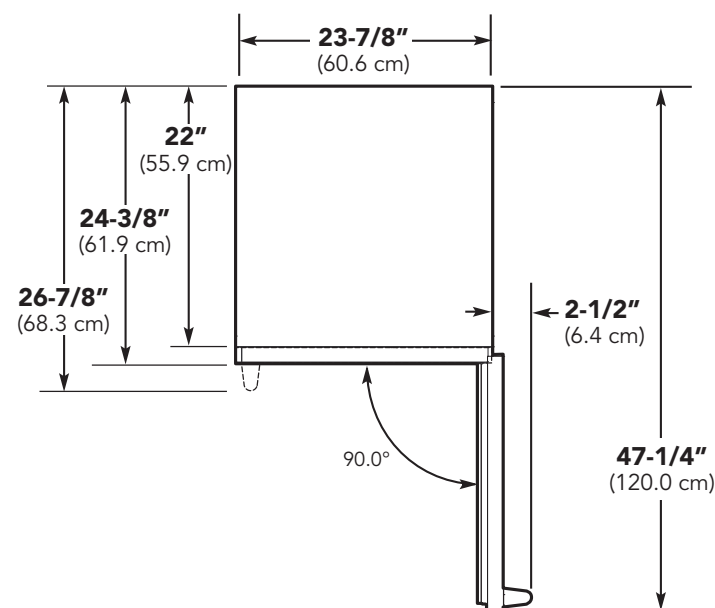

**Door Swing VUWC 24"W. - Dual Zone**

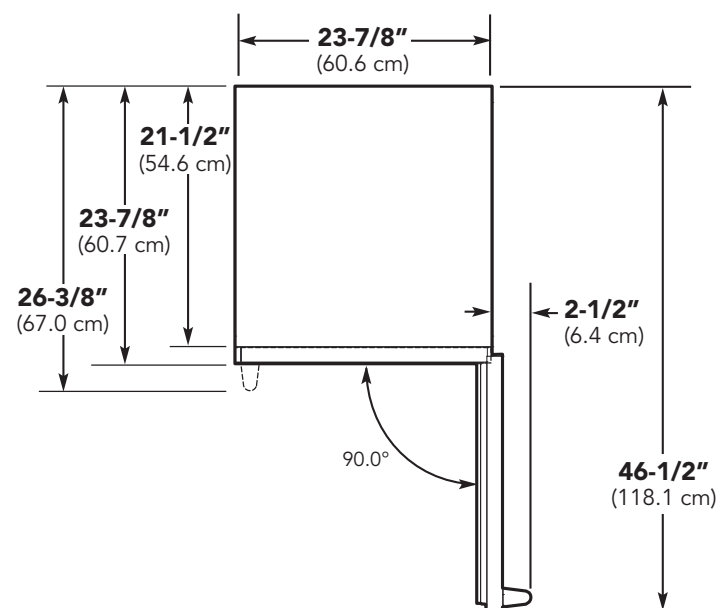

**SPECIFICATIONS/DIMENSIONS  
DESIGNER - 24" W. Models**

**Basic Electric Data**

- 115 VAC/60 Hz
- Maximum amps - 3.3
- Approximate Shipping Weight  
Single Zone - 140 lbs. (63.2 kg)  
Dual Zone - 170 lbs. (76.5 kg)

**Dimensions DUWC 24"W. - Single Zone**

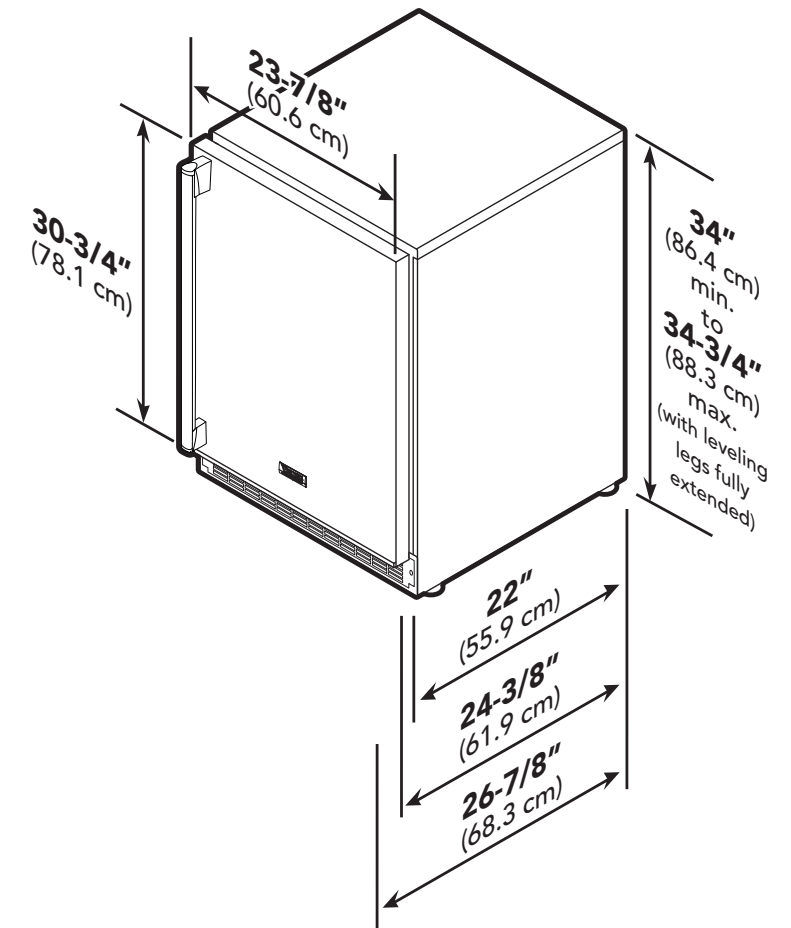

**Door Swing DUWC 24"W. - Single Zone**

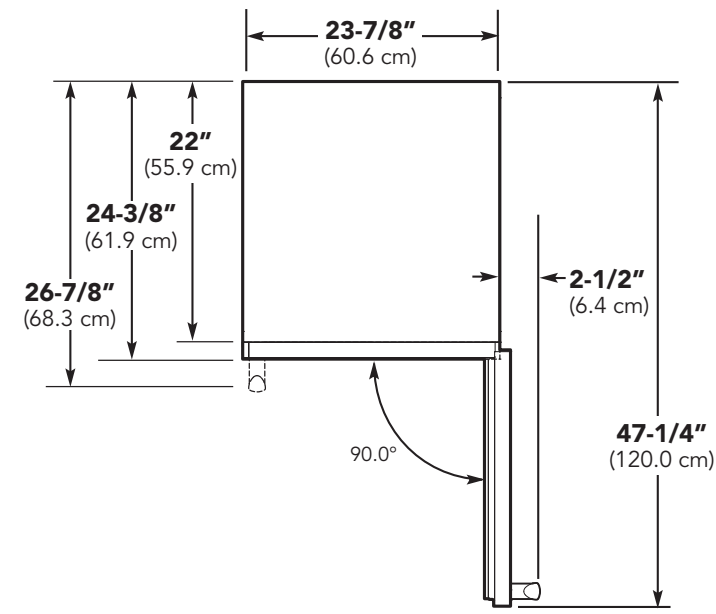

**Door Swing DFUW 24"W. - Single Zone**

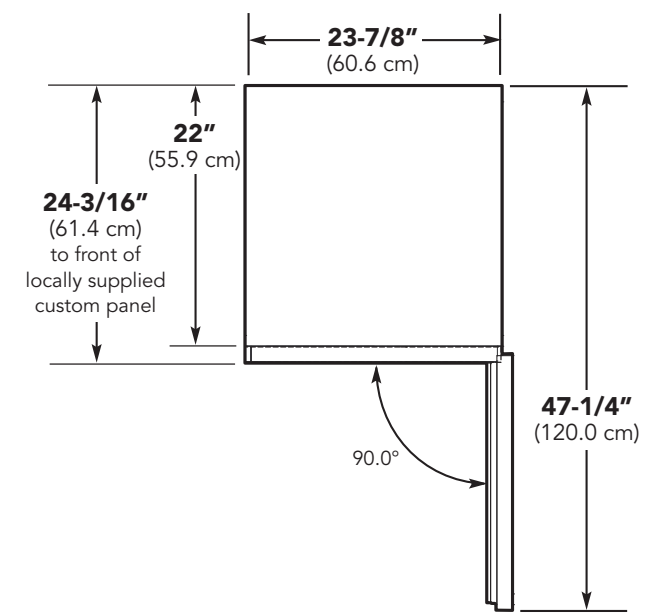

## SPECIFICATIONS/DIMENSIONS

### DESIGNER - 24" W. Models

#### Basic Electric Data

- 115 VAC/60 Hz
- Maximum amps - 3.3
- Approximate Shipping Weight  
Single Zone - 140 lbs. (63.2 kg)  
Dual Zone - 170 lbs. (76.5 kg)

#### Dimensions DFUW 24"W. - Dual Zone

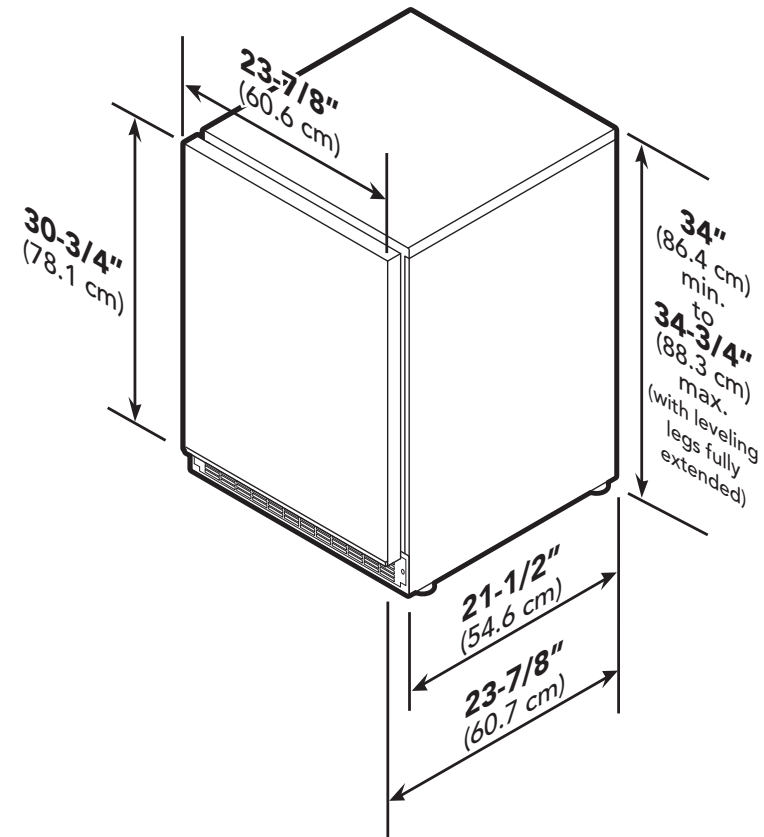

#### Door Swing DFUW 24"W. - Dual Zone

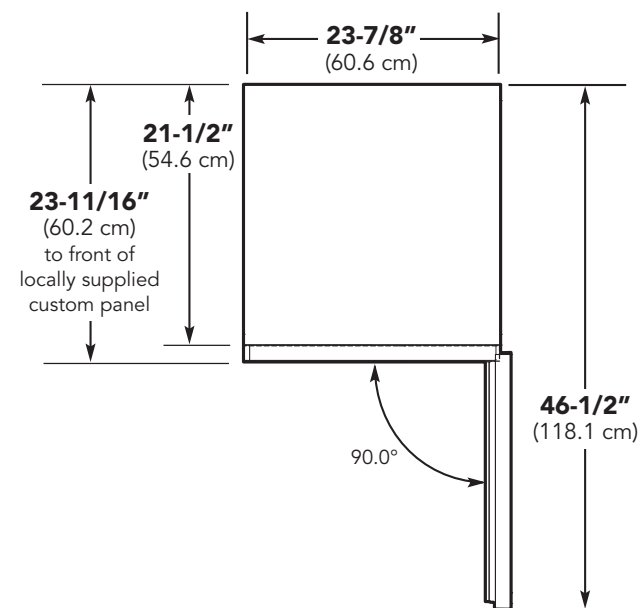

## CUSTOM WOOD FRAME INSTALLATION (DFUW Model)

**NOTE:** Weight of wood panel must not exceed 20 lbs.

### Step 1: Verify door alignment

The door should be parallel to the sides and top of the refrigerator. If alignment is necessary the door may be adjusted by loosening the 2 screws which secure the hinge adapter brackets to the door and adjusting the door side to side. Use a 5/32" allen wrench for this procedure. (See Figure 1 below).

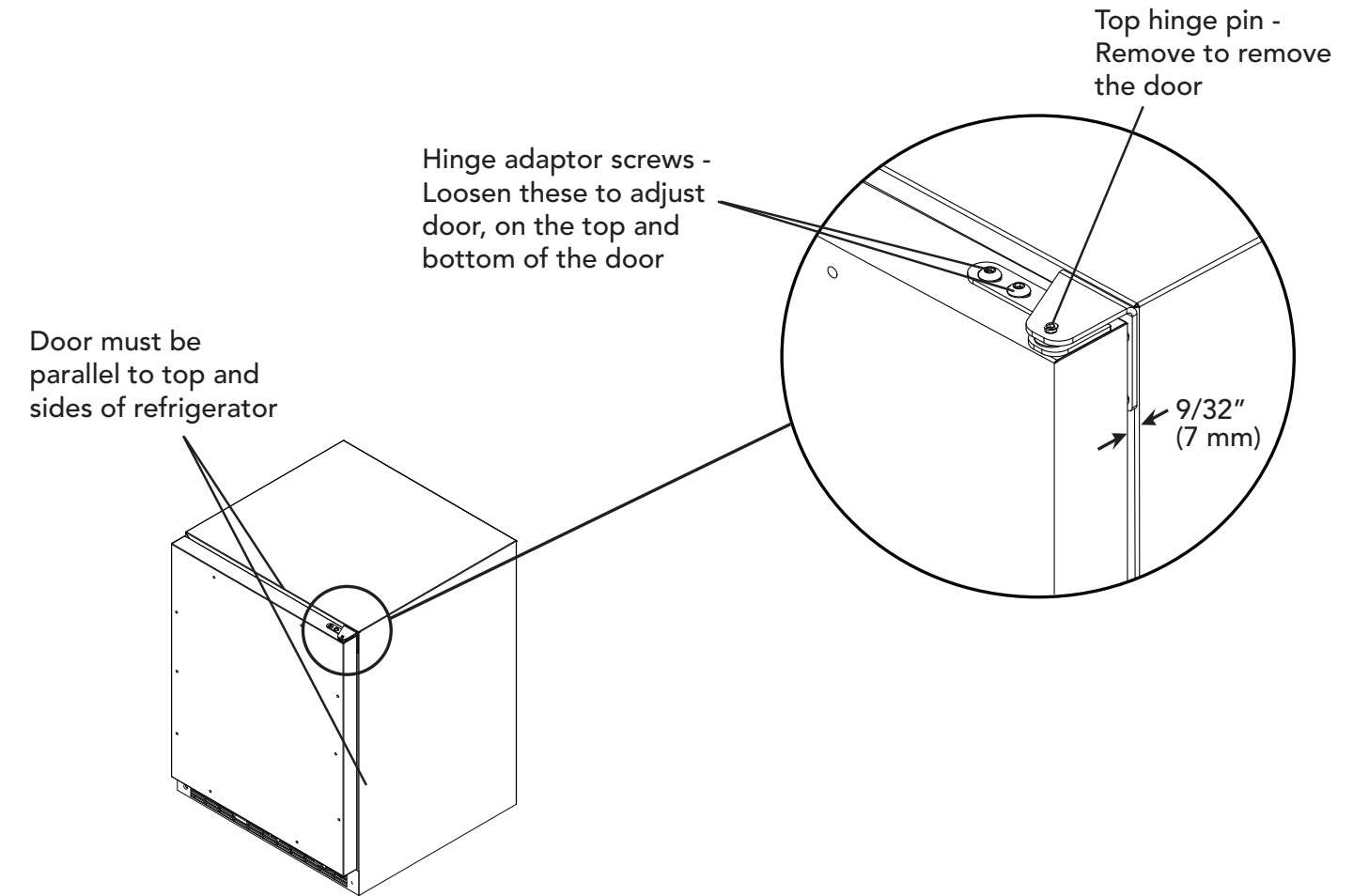

Figure 1

### Step 2: Remove door

Remove the top hinge pin from the hinge with an 1/8" allen wrench. Remove the door by angling the top of the door outward and lifting the door off the bottom hinge. (See detail in Figure 1).

### Step 3: Remove gasket

Lay the door on its front being careful not to scratch it. Remove the door gasket by peeling up and out of the channel.

### Step 4: Cut overlay panel

Depending on the refrigerator model cut the overlay panel to the dimensions shown. Use Figure 2 and Table A.

**Note:** For overlay with lock option, panel thickness to be 3/4" (19 mm) maximum to 5/8" (16 mm) minimum.

**Note:** For the door closer to work properly, it is necessary to maintain a minimum space of 9/32" (7mm) between the door and cabinet flange as shown. This space can be adjusted by adjusting the top and bottom hinge adapters.

**CUSTOM WOOD FRAME INSTALLATION (DFUW Model) (cont.)**

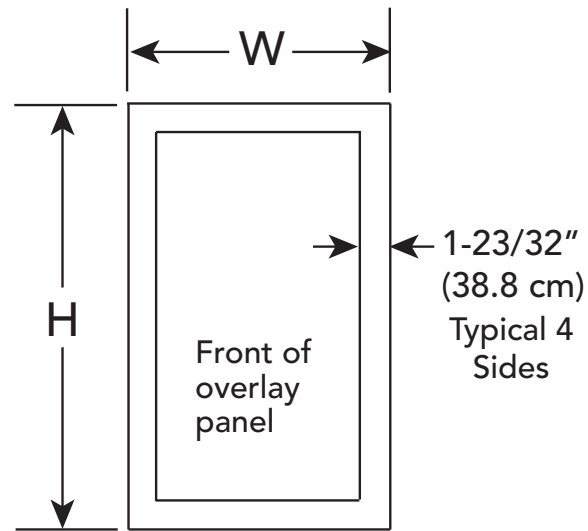

Figure 2  
Glass Door Models

Model	W	H
15"	14-5/16" (36.4 cm)	30-5/16" (76.9 cm)
24"	23-7/16" (59.5 cm)	30-5/16" (76.9 cm)

Table A  
Glass Door Models

**Step 5: Clamp panel to door**

Set the overlay panel on the door front, align the edges, and clamp together. Clamp the panel firmly but be careful not to crush the foam in the door or scratch the door.

**Step 6: Drill holes in overlay panel**

Remove the hinge adapter bushings from the top and bottom door hinge adapters. (See Figure 6). Using the holes in the hinge adapters drill 5/16" (8 mm) diameter clearance holes into the overlay panels 3/4" (20 mm) deep. These will be clearance holes for the top and bottom hinge pins.

Also, at this time, drill the screw pilot holes for attaching the overlay panel to the door. Select the size of the hole from Table B. Be careful not to drill the pilot holes through the overlay panel but only 1/2" (12.7 mm) deep.

Material Type	#8 Wood Screw
Hardwood	3/32" (2.4 mm) Diameter. Pilot Hole
Softwood	5/64" (2.0 mm) Diameter. Pilot Hole

Table B

**CUSTOM WOOD FRAME INSTALLATION (DFUW Model) (cont.)**

**Step 7: Mark and drill lock hole**

Locate and mark with a pencil the location of the lock hole on the overlay panel, this is the hole in the top corner of the handle side of the door. Remove the clamp and remove the overlay panel from the door. On the backside of the panel where you marked the lock location drill a 13/16" (20.5 mm) diameter counter bore 7/16" (11.0 mm) deep into the overlay panel. Drill a 15/32" (12.0 mm) diameter hole through the overlay panel centered on the counterbore being careful not to splinter the wood on the face side of the panel. (See Figure 3).

**Step 8: Assemble the lock parts**

Two (2) lock extensions are supplied with the lock. Use the longer extension for a 3/4" thick overlay panel and the shorter one for a 5/8" thick panel. Assemble the lock extension, cam stop washer, spring washer, and set screw to the lock as shown in Figure 3 and 4.

Install this assembly into the overlay panel and secure with the retaining nut using a 15mm socket. Make sure the key slot in the lock is vertical.

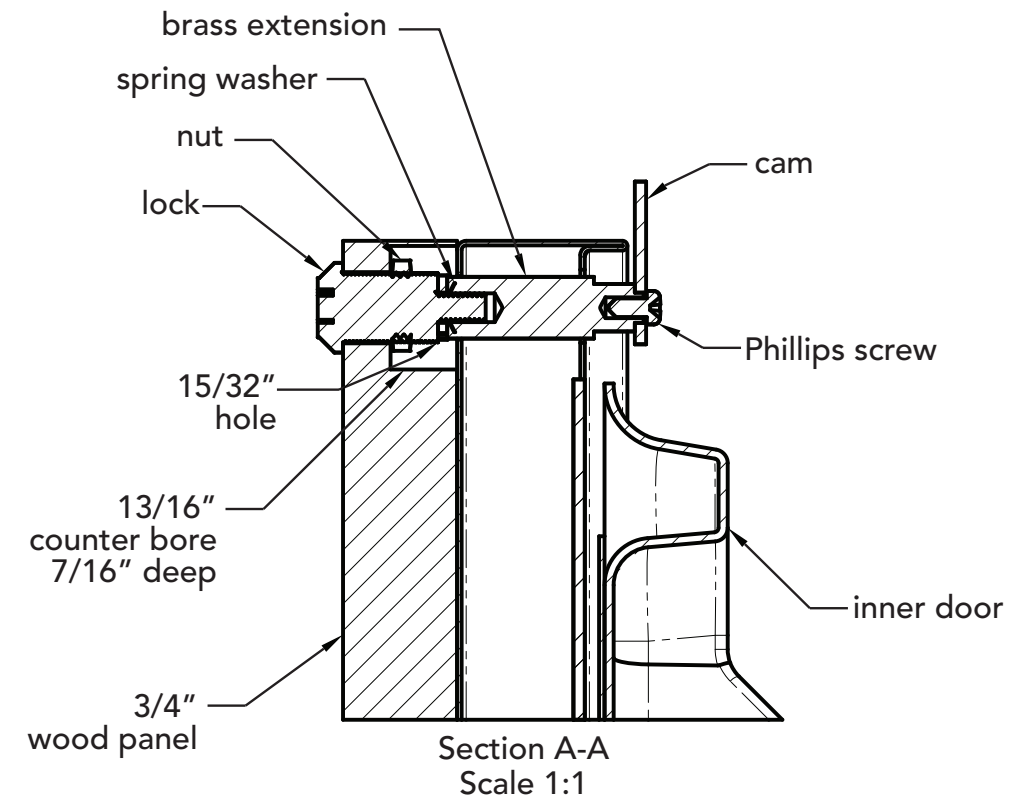

Figure 3

**CUSTOM WOOD FRAME INSTALLATION (DFUW Model) (cont.)**

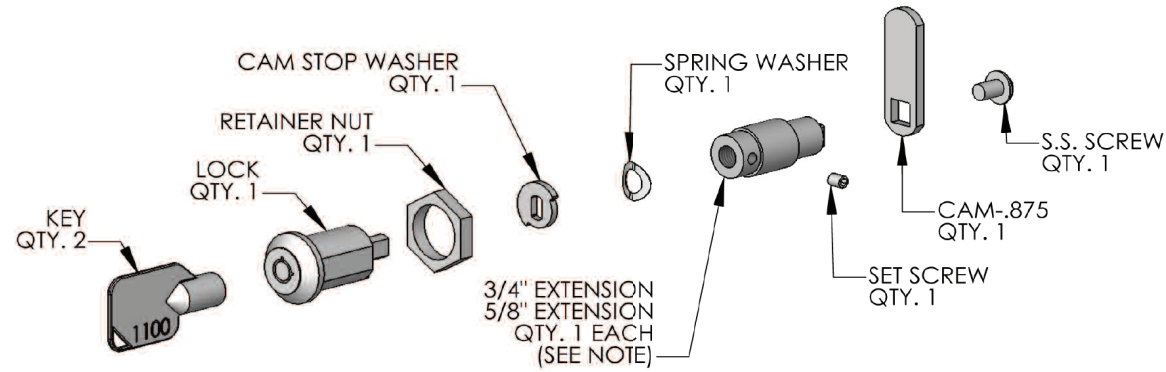

Figure 4

**Step 9: Secure overlay panel to the door**

With the #8 wood screws provided, fasten the overlay panel to the door. (See Figure 5).

**Step 10: Install lock cam**

Attach the lock cam to the back of the lock assembly with the Phillips head machine screw provided. Orient the lock cam vertically when installing on the lock.

**Step 11: Install door gasket**

Press the door gasket into the door channel. Make certain the gasket corners are fully inserted. If applicable insert the key into the lock and make certain the lock operates properly.

**Step 12: Install the door**

Install the top and bottom hinge adapter bushings back into the hinge adapters that were removed in Step 6. Install the door by reversing the procedure from Step 2. Install the top hinge pin so the screw head is flush with the top surface of the hinge. If applicable insert key into lock and verify the lock cam works properly with the catch bracket on the front of the refrigerator cabinet.

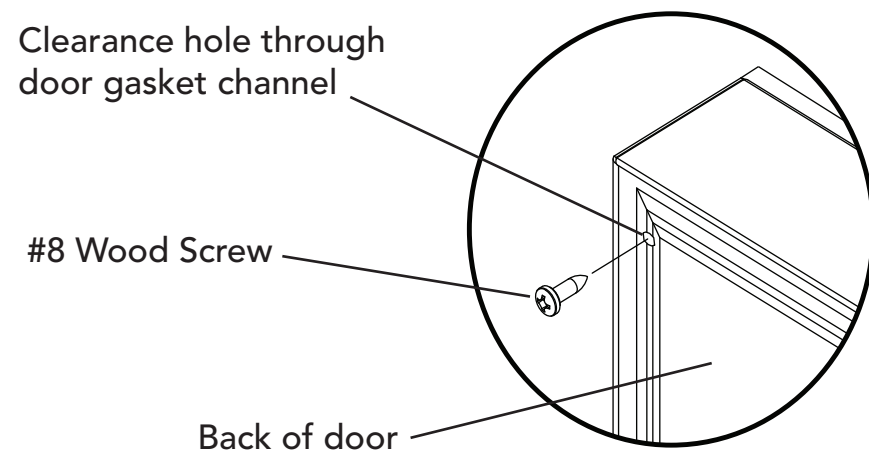

Figure 5

**CUSTOM WOOD FRAME INSTALLATION (DFUW Model) (cont.)**

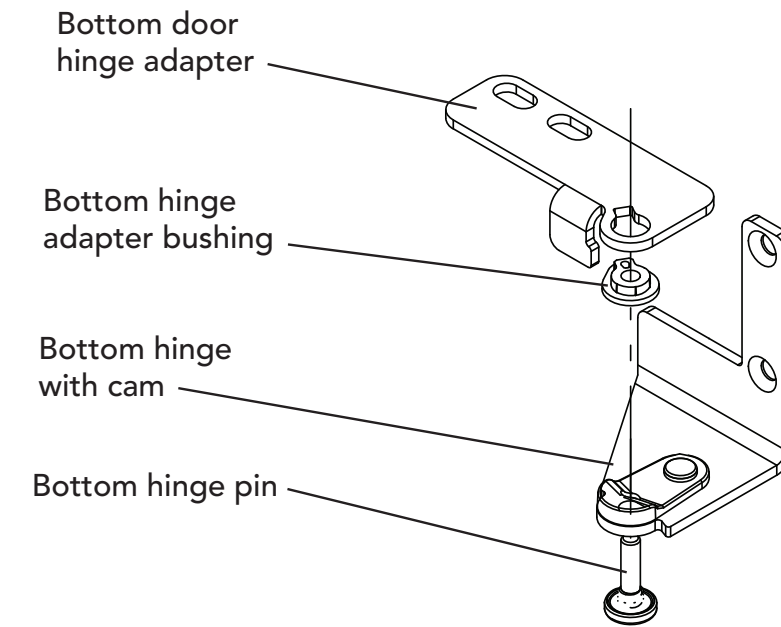
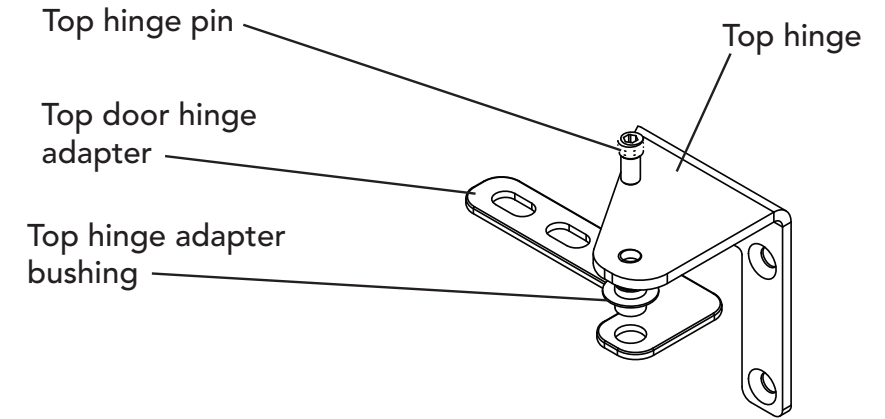

Figure 6  
Right Hand hinges shown

**LEG LEVELER INSTALLATION**

Read Before Installing Leg Levelers

**⚠ WARNING**

Do not lay unit on top, side, back, or front. If unit is accidentally laid in any position other than right side up, then the unit must remain in the upright position for at least 24 hours before plugging the unit in.

1. Four leveling legs are pre-installed in the base of the unit at the factory.
2. The unit should be leveled from front to back and side to side. If floor conditions do not allow the unit to sit level, adjust the leg levelers by turning the required leg leveler counter-clockwise to increase the height and clockwise to reduce the height.

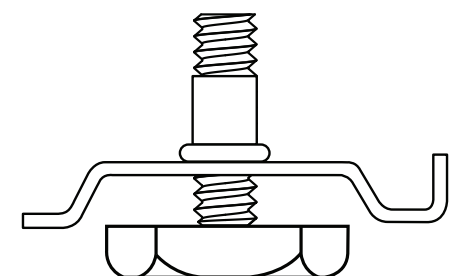

## ELECTRICAL CONNECTION

### ⚠ WARNING

#### ELECTRICAL SHOCK HAZARD

Failure to follow these instructions could result in fire or electrical shock.

#### Electrical Requirements

A 115 volt, 60 Hz, AC only 15 amp fused electrical supply is required. (A time delay fuse or circuit breaker is recommended.) It is recommended that a separate circuit, serving only this appliance, be provided.

- **ELECTRICAL GROUND IS REQUIRED ON THIS APPLIANCE.**
- **DO NOT UNDER ANY CIRCUMSTANCES REMOVE THE POWER SUPPLY CORD GROUND PLUG.**
- **DO NOT USE AN EXTENSION CORD.**

#### Recommended Grounding Methods

For your personal safety, this refrigeration product must be grounded. This appliance is equipped with a 5' power supply cord having a 3-prong grounding plug. To minimize possible shock hazard, the cord must be plugged into a mating 3-prong grounding type wall receptacle grounded in accordance with the National Electrical Code and local codes and ordinances. If the circuit does not have a grounding type receptacle, it is the responsibility and obligation of the customer to exchange the existing receptacle in accordance with the National Electrical Code and applicable local codes and ordinances. The third ground plug **SHOULD NOT**, under any circumstances, be cut or removed. All UL listed refrigerated products are equipped with this type of plug.

## FINAL PREPARATION

1. Some stainless steel parts may have a plastic protective wrap which must be peeled off. The interior of the wine cellar should be washed thoroughly with hot, soapy water, rinsed and wiped dry to remove film residue and any installation dust or debris before being used. Solutions stronger than soap and water are rarely needed.
2. All stainless steel parts should be wiped with hot soapy water. If buildup occurs, do not use steel wool, abrasive cloths, cleaners, or powders. If it is necessary to scrape stainless steel to remove encrusted materials, soak with hot, wet cloths to loosen the material, then use a wood or nylon scraper. Do not use a metal knife, spatula, or any other metal tool to scrape stainless steel; scratches are almost impossible to remove.

## LIGHT ASSEMBLY REPLACEMENT - 15" W. Models

### ⚠ DANGER

#### ELECTRICAL SHOCK HAZARD

Failure to to disconnect the power cord when changing the light tube, could result in fire or electrical shock.

**NOTE:** Please contact your local Viking Range Corporation parts distributor or dealer to order a new light assembly.

To replace the light, first disconnect the unit's power cord. Next, remove both the green ground wire screw located on the left of the light assembly and the other screw located on the right of the light assembly with a 5-16" hex head screwdriver. (See drawing). Unplug the light unit and remove complete light assembly.

To install the new light assembly, screw in the green ground wire screw and the screw located on the right with a 5/16" hex head screwdriver and plug the light unit in.

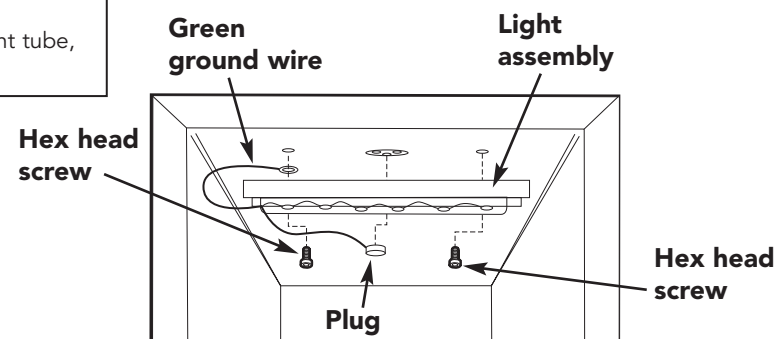

## LIGHT TUBE REPLACEMENT - 24" W. Single Zone Models

### ⚠ DANGER

#### ELECTRICAL SHOCK HAZARD

Failure to to disconnect the power cord when changing the light tube, could result in fire or electrical shock.

**NOTE:** Please contact your Viking Range Corporation parts distributor or dealer to order new light tubes. Use only approved replacement light tubes from your dealer or manufacturer.

This product uses two 6-watt light tubes to illuminate the interior of the wine cellar. The light tubes are very reliable electrical components, but should either or both light tubes not function properly, please call your local dealer for replacement light tubes. To replace the light tube:

- Use a small Phillips head screwdriver to remove the two screws holding the cover plate over the back section of the light tube. Set the screws and cover plate aside for re-assembly later.
- Using a small flat-blade screwdriver, gently lever the front section of the light tube down to allow it to be pulled clear of the light housing. Disconnect the two insulated electrical connectors from the cabinet's electrical cable and discard the old light tube.
- Reconnect the insulated electrical connector of the new light tube to the cabinet's electrical cable connectors. Make sure they are secure and fully inserted.
- Carefully realign the light tube's electrical terminals back into the rear of the light enclosure channel making sure not to crimp them. Gently insert the light tube along the length of the light enclosure channel. Press the light tube gently into the light enclosure channel. Only a small part of the light tube should project below the ceiling of the unit. **DO NOT USE A HAMMER TO FIT THE LIGHT TUBE.**
- Place the light tube terminal cover plate back in its original position on the light enclosure's flange. Re-use the original two screws to secure the cover in place. Plug the unit into the electrical socket. Check to see if the light tubes operate properly.

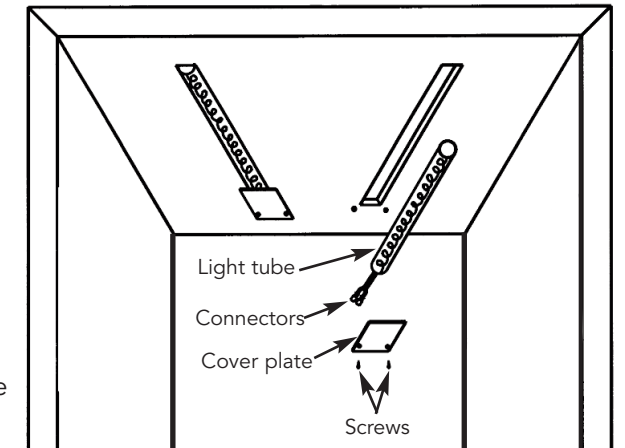

## LIGHT TUBE REPLACEMENT - 24" W. Dual Zone Models

### ⚠ DANGER

#### ELECTRICAL SHOCK HAZARD

Failure to to disconnect the power cord when changing the light tube, could result in fire or electrical shock.

**NOTE:** Please contact your Viking Range Corporation parts distributor or dealer to order new light tubes. Use only approved replacement light tubes from your dealer or manufacturer.

This product uses two light tubes to illuminate the interior of the wine cellar. There is one light tube located behind the control housing in the the upper compartment and one light tube attached to the underside of the cabinet divider in the lower compartment.

Use replacement instructions and drawing from the 15"W. Models for this Dual Zone product.



## SETTING THE CONTROLS - SINGLE ZONE

The temperature of the wine cellar ranges from 40°F (4°C) to 65°F (18°C).

# TruProtect™ "Basic" Function "Quick" Reference

### Solid Door Single Zone Models:

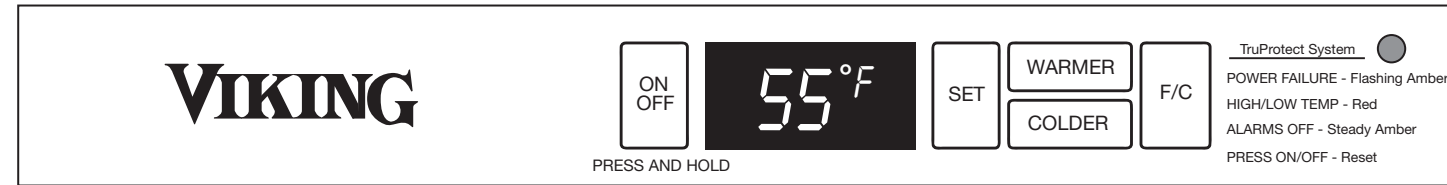

Function	Function Access
Turn Unit On & Off	Pressing and holding the  key for 5-seconds will turn the unit "ON" or "OFF".
Adjust Temperature Set-Point	To adjust temperature set-point, touch  keypad and current set-point will be displayed. Use the  or  keypads to adjust set-point temperature.
Display "Actual" Temperature	Display represents "real-time" monitoring of the compartments stored wine and/or contents. Some temperature fluctuation around your desired set-point is normal.
Select °F or °C Display	Pressing the  keypad will toggle the display between Fahrenheit and Centigrade temperature display.
Black-Out Mode	Display automatically shuts off when door is closed.
Display Lighting	Display Lighting can be enabled with the door closed by pressing the  keypad.
Sabbath Mode	Press and hold the  keypad while pressing the  keypad four (4) times.
TruProtect™ System	System monitoring is automatically enabled unless system has been disabled. (See below.)
Door Ajar Alarm	For Door Ajar Alarm, TruProtect must be Enabled, (See "Disable/Enable TruProtect", described below.)
High/Low Temp Alarm	<b>Note:</b> Alarm may occur when changing set-points in excess of 10°F, and/or high usage, this is normal. TruProtect must be Enabled, (See "Disable/Enable TruProtect", described below.)
Power Failure Alarm	<b>Note:</b> Alarm will occur upon initial installation, since unit was run at factory to verify quality, this is normal. TruProtect must be Enabled, (See "Disable/Enable TruProtect", described below.)
Reset Alarms	Close door to reset Door Ajar alarm. Press  keypad to reset all other alarms.
Disable/Enable TruProtect™ System	Press and hold the  keypad for 5-seconds to "disable" or "enable" TruProtect™ System.

### Glass Door Single Zone Models:

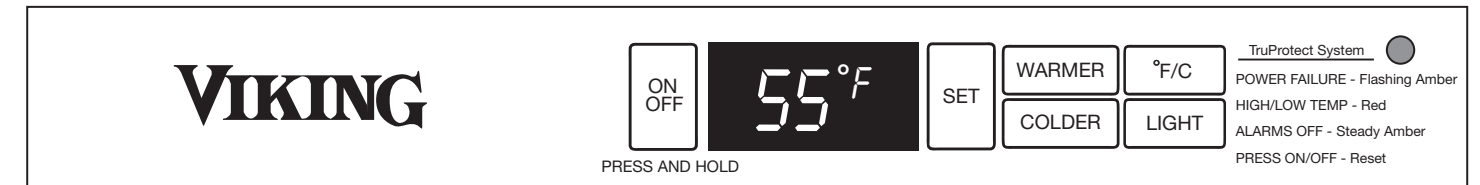

Control Confirmation/Comment
Display will be blank  when refrigeration system is off. Lights will still function, but will time-out 15 minutes after each activation, if door is left open or display lighting is on, to prevent overheating. "Set" will appear in display  when in set-point mode. "SET" mode will automatically time-out in 10 seconds if no keypad activity occurs, or you may exit "SET" mode by pressing the  keypad a second time.
Temperature variation in "compartment air", above and below set-point, is a normal effect of refrigeration system cycling on and off. Stored items will not experience the full temperature swing of the compartment air due to the dampening effect of their thermal mass. 
In addition, the control panel is hidden when door is closed.
Option available on Glass Door Models only.
Display will flash  to confirm your selection, then unit will enter Sabbath Mode. The display, audible alarms, LED and lights will be disabled. Sabbath Mode will automatically time-out in 36 hours, or can be exited by repeating the enable keypad routine.
LED displays steady green  when TruProtect™ is enabled.
Audible alarm will sound 3-times every 30-seconds, LED will flash green.
Alarm will sound 6-times every minute and LED will flash red  if product temperature excursions occur for a duration outside acceptable limits.
LED will flash amber  whenever power is interrupted to unit. No audible signal.
Note that although pressing the  keypad will reset the alarms, the alarm will resume if the "alarm condition" still exists.
LED displays steady green  when alarms enabled. LED displays steady amber  when disabled.

## SETTING THE CONTROLS - DUAL ZONE

The temperature of the wine cellar ranges from 40°F (4°C) to 65°F (18°C).

# TruProtect™ "Basic" Function "Quick" Reference

### Solid Door Dual Zone Models:

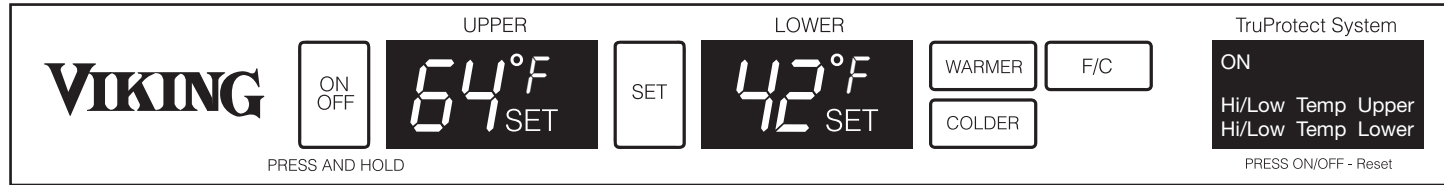

Function	Function Access
Turn Unit On & Off	Pressing and holding the  key for 5-seconds will turn the unit "ON" or "OFF".
Adjust Temperature Set-Point	To adjust temperature set-point, press the  key. When a compartment is in "SET" mode, a "SET" icon will be displayed. Pressing either the  or  keys located on the display pad will raise or lower the set temperature by one (1) °F or °C (depending on your setting).
Display "Actual" Temperature	Display represents "real-time" temperature of each compartment's stored wine and/or contents. Some minor temperature fluctuation around your desired set-point is normal.
Select °F or °C Display	Pressing the  key will toggle the display between Fahrenheit and Centigrade temperature display.
Black-Out Mode	Display automatically shuts off when the door is closed.
Display Lighting	Display lighting can be enabled with the door closed by pressing the  key.
Sabbath Mode	Press and hold the  key while pressing the  key four (4) times in seven (7) seconds.
TruProtect™ System	System monitoring is automatically enabled unless system has been shut off (see below).
Door Ajar Alarm	For Door Ajar Alarm, TruProtect must be Enabled, (See "Disable/Enable TruProtect", described below.)
High/Low Temp Alarm	NOTE: Alarm may occur when changing set-points in excess of 10°F, and/or high usage, this is normal. TruProtect must be Enabled, (See "Disable/Enable TruProtect", described below.)
Power Failure Alarm	NOTE: Alarm will occur upon initial installation, since unit was run at factory to verify quality, this is normal. TruProtect must be Enabled, (See "Disable/Enable TruProtect", described below.)
Reset Alarms	Close door to reset "DOOR AJAR" Alarm. Press the  key to reset all other alarms.
Disable/Enable TruProtect™ System.	Press and hold the  key for five (5) seconds to enable or disable the TruProtect™ System.

### Glass Door Dual Zone Models:

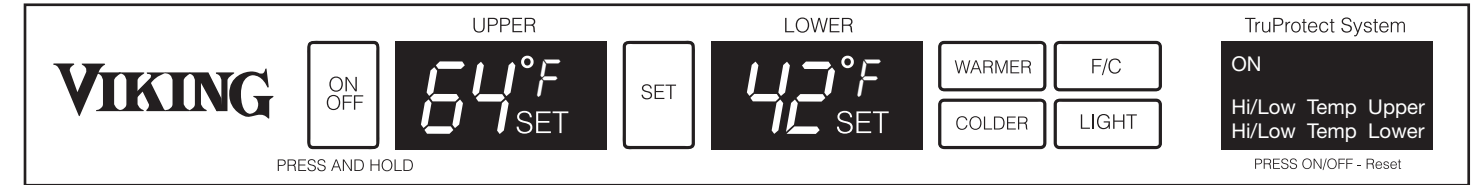

Control Confirmation/Comment
Display will be blank when the refrigeration system is off. Lights will still function, but will time-out in 15 minutes after each activation if door is left open or display lighting is on, to prevent overheating.
"SET" mode will automatically time-out in ten (10) seconds and default to actual content temperature if no keypad activity occurs, or you may exit "SET" mode by pressing the  key until "SET" icon disappears.
Temperature variation in "compartment" air, above and below set-point, is a normal effect of the refrigeration system cycling on and off. Stored items will not experience the full temperature swing of the compartment air due to the dampening effect of their thermal mass.
=
In addition, the control panel is hidden when the door is closed.
Display lighting stays on continuously.
The display will flash  to confirm your selection, then the unit will enter Sabbath Mode. The display, audible alarms, message center and lights will be disabled. Sabbath Mode will automatically time-out in 72 hours, or can be exited by repeating the enabling process.
TruProtect™ System message center displays a green "ON" when TruProtect™ is enabled and an amber "OFF" when TruProtect™ is disabled.
An audible alarm will sound 3 times every 30 seconds and the message center will display an amber "DOOR AJAR".
An audible alarm will sound 6 times every minute and the message center will display a red "HI/LOW TEMP UPPER" or a red "HI/LOW TEMP LOWER" if product temperature excursions occur for a duration outside acceptable limits.
The message center will display an amber "POWER FAILURE" whenever power is interrupted to the unit. There is no audible alarm with a power failure.
Although pressing the  key resets the alarms, the alarm will resume if the "alarm condition" still exists.
The message center displays a green "ON" when the alarms are enabled.

### LOADING RECOMMENDATIONS - 15" W. Models

Each of the six roll-out racks hold four bottles. The necks of the bottles alternate front to back. To aid in loading/unloading, the racks extend up to 14 inches (35.6 cm) to allow easier access to the rear bottles. Bottom racks may be removed for storing "jug" wines. Magnums and other large bottles may be stored by removing the rack directly above the intended storage rack. To remove a rack, first unlock the rack by pushing the lock backward. The lock is located on the bottom front of each rack. After reinserting the rack, push the lock forward to lock the rack back into place.

Bottles on the top rack directly under the light will be exposed to slightly higher temperature when the light is on. Store red wines on the upper racks where the temperature is higher and white wines on the middle or lower racks where the temperature is lower. **REMEMBER TO TURN OFF THE LIGHT WHEN IT IS NO LONGER NEEDED.**

Store wines intended for everyday use on the front half of the racks where labels are completely visible and place wines for aging or long term storage in the rear half of the rack. Pull wine racks out gently to minimize the unsettling of your wine collection. Avoid pulling out more than one rack at any time to maintain stability.

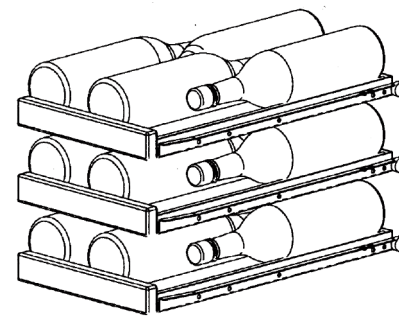
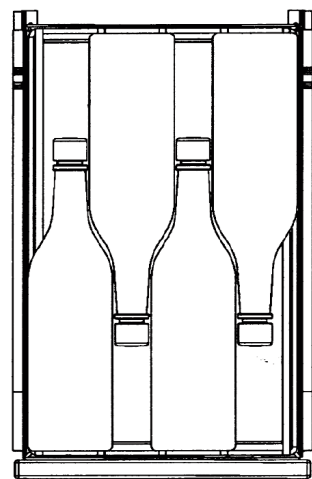
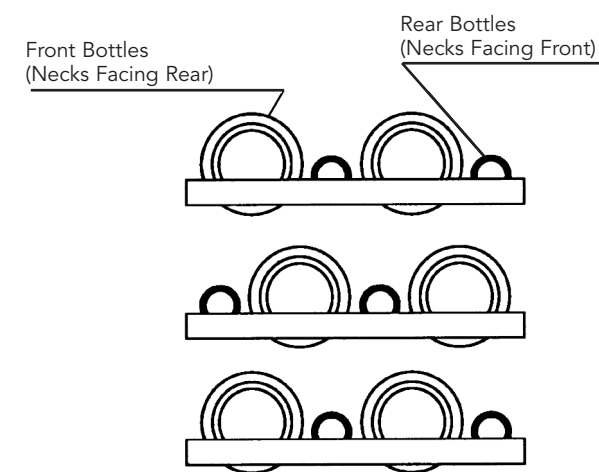

Roll-out Racks

Since the bottles are not stacked on top of each other, the single bottle rack allows easy view and access to your inventory without disturbing other bottles

### LOADING RECOMMENDATIONS - 24" W. Models

Each of the top five roll-out racks holds 8 bottles with necks alternating front to back. The bottom shelf holds four bottles for a total of 44 bottles. To aid in the loading and unloading, the racks extend up to 14 inches (35.6 cm) to allow easier access to rear bottles. Tall bottles should not be loaded on the bottom rack because they may prevent the door from closing. The bottom rack may be removed for storing "jug" wines. You may store magnum and other large bottles on the upper right and left positions of the cabinet shelving or on any of the middle racks by removing the rack directly above them. To remove a rack, first unlock the rack by pushing the lock backward. The lock is located on the bottom front of each rack. After reinserting the rack, push the lock forward to lock the rack back into place. Position white wines on the middle or lower racks and red wines on the upper racks.

Bottles on the top rack directly under the light will be exposed to a slightly higher temperature when the light is on. **REMEMBER TO TURN OFF THE LIGHT WHEN IT IS NO LONGER NEEDED.**

Store wines intended for everyday use on the front half of the racks where labels are completely visible and place wines for aging or long term storage in the rear half of the rack. Pull wine racks out gently to minimize the unsettling of your wine collection. Avoid pulling out more than one rack at any time to maintain stability.

### LOADING RECOMMENDATIONS - 24" W. Single Zone Models

Each of the top six roll-out racks holds 8 bottles with necks alternating front to back. The bottom wood cradle holds six bottles for a total of 54 bottles. To aid in the loading and unloading, the racks extend up to 14 inches (35.6 cm) to allow easier access to rear bottles. Tall bottles should not be loaded on the bottom rack because they may prevent the door from closing. The bottom rack may be removed for storing "jug" wines. You may store magnum and other large bottles on the upper right and left positions of the cabinet shelving or on any of the middle racks by removing the rack directly above them. To remove a rack, first unlock the rack by pushing the lock backward. The lock is located on the bottom front of each rack. After reinserting the rack, push the lock forward to lock the rack back into place. Position white wines on the middle or lower racks and red wines on the upper racks.

Bottles on the top rack directly under the light will be exposed to a slightly higher temperature when the light is on. **REMEMBER TO TURN OFF THE LIGHT WHEN IT IS NO LONGER NEEDED.**

Store wines intended for everyday use on the front half of the racks where labels are completely visible and place wines for aging or long term storage in the rear half of the rack. Pull wine racks out gently to minimize the unsettling of your wine collection. Avoid pulling out more than one rack at any time to maintain stability.

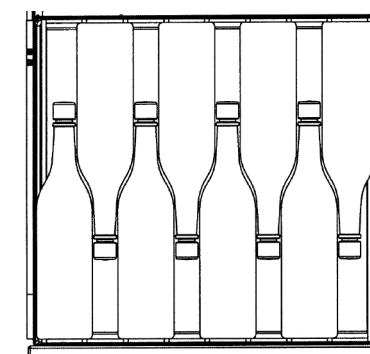
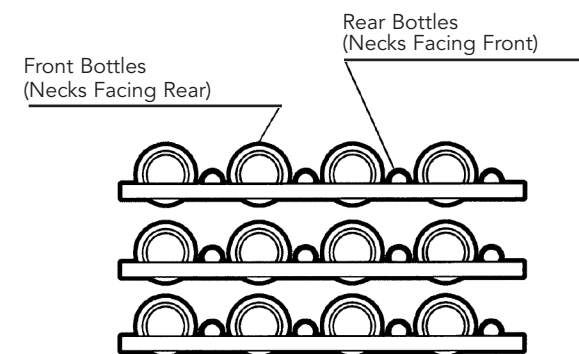

Since the bottles are not stacked on top of each other, the single bottle roll-out rack allows easy view and access of your inventory without disturbing other bottles.

### LOADING RECOMMENDATIONS - 24" W. Dual Zone Models

Both zones can be set for either temperature range, red or white, but for more efficient energy usage and functionality of the unit, it is better to use the top compartment for reds (warmer) and the bottom compartment for whites (cooler).

Each of the top five roll-out racks holds 8 bottles with necks alternating front to back. The bottom shelf holds four bottles for a total of 44 bottles. To aid in the loading and unloading, the racks extend up to 14 inches (35.6 cm) to allow easier access to rear bottles. Tall bottles should not be loaded on the bottom rack because they may prevent the door from closing. The bottom rack may be removed for storing "jug" wines. You may store magnum and other large bottles on the upper right and left positions of the cabinet shelving or on any of the middle racks by removing the rack directly above them. To remove a rack, first unload all wine bottles then pull the rack out and upward. Position white wines on the middle or lower racks and red wines on the upper racks.

Bottles on the top rack directly under the light and on the rack directly below the separator shelf will be exposed to a slightly higher temperature when the light is on. **REMEMBER TO TURN OFF THE LIGHT WHEN IT IS NO LONGER NEEDED.**

Store wines intended for everyday use on the front half of the racks where labels are completely visible and place wines for aging or long term storage in the rear half of the rack. Pull wine racks out gently to minimize the unsettling of your wine collection. Avoid pulling out more than one rack at any time to maintain stability.

## CLEANING AND MAINTENANCE

Any piece of equipment works better and lasts longer when maintained properly and kept clean.

### Condenser

The condenser underneath the cabinet does not require frequent cleaning; however, satisfactory cooling depends on adequate ventilation over this heat exchanger. It is recommended to annually clean the condenser by vacuuming and brushing. To access the condenser, the unit must be pulled out from the installation and the lower machine compartment access cover removed.

## ⚠ WARNING

Disconnect the power cord before removing the access cover.

Be sure that nothing obstructs the required air flow openings in front of the cabinet. At least once or twice a year, brush or vacuum lint and dirt from the front grille area.

### Cabinet

The cabinet can be washed with mild soap and water and thoroughly rinsed with clear water. **NEVER** use abrasive scouring powders.

### Interior

Wash interior compartment with mild soap and water. **DO NOT USE** abrasive powder, solvent, polish cleaner or undiluted detergent.

### Stainless Steel Parts

All stainless steel parts should be wiped regularly with hot soapy water. Use a liquid cleaner designed for stainless steel when soapy water will not do the job. **DO NOT USE** steel wool, abrasive cloths, cleansers, or powders. **DO NOT** permit citrus or tomato juice to remain on stainless steel surfaces, as citric acid will permanently discolor stainless steel.

### Brass Parts

**CAUTION:** All brass parts are coated with an epoxy coating. **DO NOT USE BRASS OR ABRASIVE CLEANERS ON THE BRASS PARTS.** All brass parts should be wiped regularly with hot soapy water. When hot soapy water will not do the job, use every day non-abrasive household cleaners.

### Glass Door

Use a glass cleaner or mild soap and water with a soft cloth to clean the glass door. **DO NOT USE** any abrasive powders. On full overlay models, use caution when cleaning near logo area.

### Painted Surfaces

Wash with warm soapy water. **DO NOT USE** steel wool, abrasive cleansers, ammonia, acids or commercial oven cleaners which may damage the finish.

### Door Gasket

The vinyl gasket may be cleaned with mild soap and water, a baking soda and water solution, or a mild scouring powder.

## ENERGY SAVING TIPS

The following suggestions will minimize the cost of operating your refrigeration appliance.

1. Do not install your appliance next to a hot appliance, (cooker, dishwasher, etc.), heating air duct or other heat sources.
2. Install product out of direct sunlight.
3. Assure the toe grille vents at front of unit beneath door are not obstructed. Keep toe grille vents clean to allow ventilation for the refrigeration system to expel heat.
4. Plug your appliance into a dedicated power circuit. (Not shared with other appliances.)
5. When initially loading your new product, or whenever large quantities of warm contents are placed within refrigerated storage compartment, minimize door openings for the next 12 hours to allow contents to pull down to compartment set-point temperature.
6. Maintaining a relatively full storage compartment will require less appliance run-time than an empty compartment.
7. Assure door closing is not obstructed by contents stored in your appliance.
8. Allow hot items to reach room temperature before placing in product.
9. Minimize door openings and duration of door openings.
10. Use the warmest temperature control set-point that meets your personal preference and provides the proper storage for your stored contents.
11. For wine storage products:
  - a. When serving temperatures are not required, return the compartment(s) set-point to the ideal red and white wine long term storage temperature of 13°C/55°F.
  - b. For Dual-Zone product with two (2) independent temperature controlled compartments, use the lower compartment for the coldest storage/serving temperature, (i.e. - red wines on top, white wines in lower).
12. Minimize use of display lighting option on glass door products, (light stays on with door closed).
13. When on vacation or away from home for extended periods, set the appliance to warmest acceptable temperature for the stored contents.
14. Set the control to the "OFF" position if cleaning the unit requires the door to be open for an extended period of time.
15. Annually clean condenser heat exchange coil located in machine compartment underneath unit, (see Cleaning and Maintenance section).

## TROUBLESHOOTING CHART

Problem	Possible Cause	Solution
Odor in cabinet	Unit interior needs cleaning	Clean inside of unit
Noisy operation	Unit not level	Adjust leveling legs
Unit vibrates	Unit not level	Adjust leveling legs
	Weak floor	Rebuild floor or move to a different location
Interior lighting not working	LED light burned out	Replace LED light
	No power at outlet	Test outlet with lamp
Appliance will not run	Control panel tuned "OFF"	Turn unit on with on/off pad on control panel
	Power cord not plugged into power source	Plug unit into power source
	House fuse blown	Reset house fuse
Appliance runs too long	Prolonged door openings	Reduce number and/or duration of openings
	Control panel set too cold	Raise temperature of unit via control panel
	Condenser needs cleaning	Clean condenser
Moisture collects inside of unit	Too many door openings	Reduce number of door openings
	Prolonged door openings	Reduce number of door openings
	Hot, humid weather increases condensation	Move unit to cooler location As humidity decreases, moisture will disappear
Moisture collects on outside surface of unit	Hot, humid weather increases	Move unit to cooler location
	Control improperly set	Reset to slightly warmer temperature
Interior too hot/too cold	Control improperly set	Reset control to desired temperature
	Faulty thermometer	Recheck with second thermometer

# TruProtect™ “Advanced” Function “Quick” Reference

## Solid Door Single Zone Models:

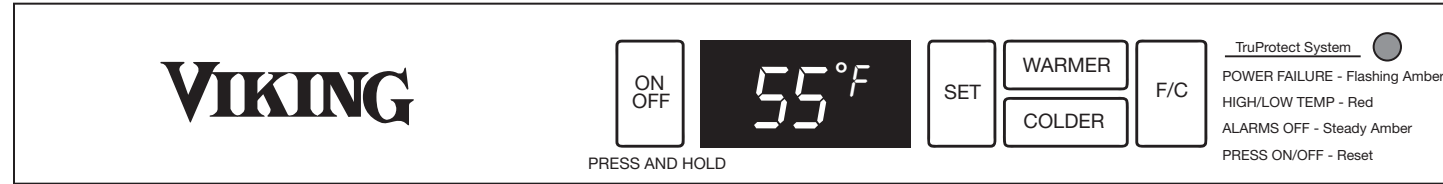

Function	Function Access
Show Room Mode	Enable the Show Room Mode by pressing and holding the  keypad while performing a “Power On Reset”, (POR), i.e. - disconnect and reconnect the power supply to unit. Exit Show Room Mode by initiating a POR only.
Service Diagnostics	<p>“Enter” and “Exit” Service Diagnostics mode by pressing and holding the  keypad while pressing the  keypad 4-times within 5-seconds. Service Diagnostics mode also will automatically exit after 5-minutes of no keypad entry.</p> <p><u>Display Error Code Reference:</u> The microprocessor in the control continually monitors critical refrigeration system components for proper operation. If component parameters exceed normal operating specifications, the display will automatically flash the respective error code as follows:</p> <ul style="list-style-type: none"> <li> ⇨ Compressor fault, (high/low amps).</li> <li> ⇨ Condenser fan motor fault, (high/low amps).</li> <li> ⇨ Evaporator thermistor “sensor B” fault, (out-of-range).</li> <li> ⇨ Display thermistor “sensor A” fault, (out-of-range).</li> </ul> <p>Power line fluctuations may cause an error code to be displayed with no product fault. Therefore, the first time an error code appears, please clear the code by holding  and pressing  4 times. If the product is at fault, the error code will appear again, and you should contact your Dealer or Viking Customer Service to schedule service by a qualified technician.</p>

## Glass Door Single Zone Models:

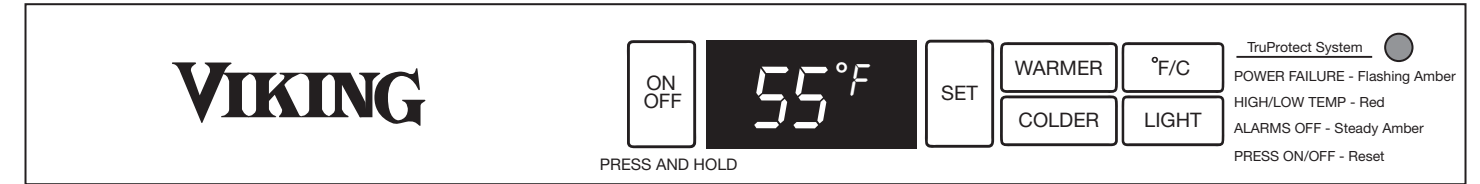

Control Confirmation/Comment				
Show Room Mode will disable the refrigerator system and fans while allowing the internal lights, display and user interface panel to function. Lights will time out after 15-minutes of continuous on-time while in Show Room Mode as a safety feature. The 15-minute light-on time can be reactivated by closing and opening the door or by pressing the keypad.				
Service Diagnostics Mode enables service technicians to identify the firmware and software versions, test status of “model specific” system components and sensors and change state of components where applicable, (i.e. - compressor on/off, etc...). While in Service Diagnostics Mode, tests are incremented by pressing the  keypad and specific component state can be changed to “on” and “off” by pressing the  and  keypads respectively. The following component tests are available:				
<u>Available Status Indicators</u>				
Test #	Component Description	OK	Off/Open	On/Shorted
0	Temp Sensor A			
1	Temp Sensor B			
2	Compressor	n/a		
3	Interior/Ice Maker Fan	n/a		
4	Reverse Gas Solenoid	n/a		
5	Condenser Fan	n/a		
6	Mullion Heater	n/a		
7	Door A Sense	n/a		
8	Door B Sense	n/a		
9	Door C Sense	n/a		
<b>Note:</b> Must use magnet to change state of Door C Sense.				

# TruProtect™ “Advanced” Function “Quick” Reference

## Solid Door Dual Zone Models:

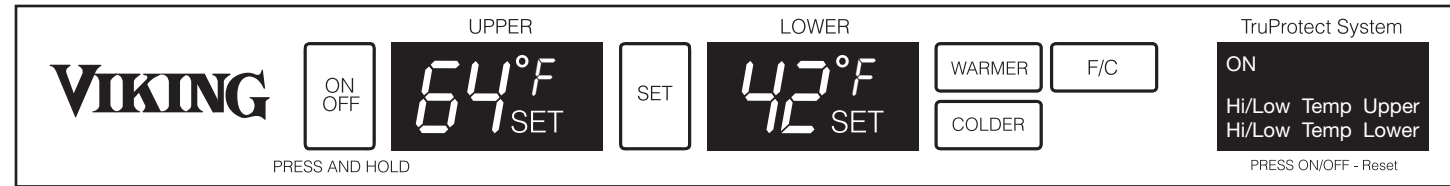

Function	Function Access
Service Diagnostics	To “Enter” and “Exit” Service Diagnostics mode, press and hold the <b>WARMER</b> keypad while pressing the <b>COLDER</b> keypad four (4) times in five (5) seconds. Service Diagnostics mode will automatically exit after five (5) minutes of no keypad entry.
	<u>Display Error Code Reference:</u> The microprocessor in the control continually monitors critical refrigeration system components for proper operation. If component parameters exceed normal operating specifications, the display will automatically flash the respective error code as follows:
	<p><b>E1</b> ⇨ Compressor Error, (High/Low Amps)</p> <p><b>E2</b> ⇨ Condenser Fan Error, (High/Low Amps)</p> <p><b>E3</b> ⇨ Upper Compartment “Sensor A” Error, (Out-of-Range)</p> <p><b>E1</b> ⇨ Lower Compartment “Sensor B” Error, (Out-of-Range)</p>
	Power line fluctuations may cause an error code to be displayed with no product fault. Therefore, the first time an error code appears, please clear the code by holding <b>SET</b> and pressing <b>ON/OFF</b> 4 times. If the product is at fault, the error code will appear again, and you should contact your Dealer or Viking Customer Service to schedule service by a qualified technician.

## Glass Door Dual Zone Models:

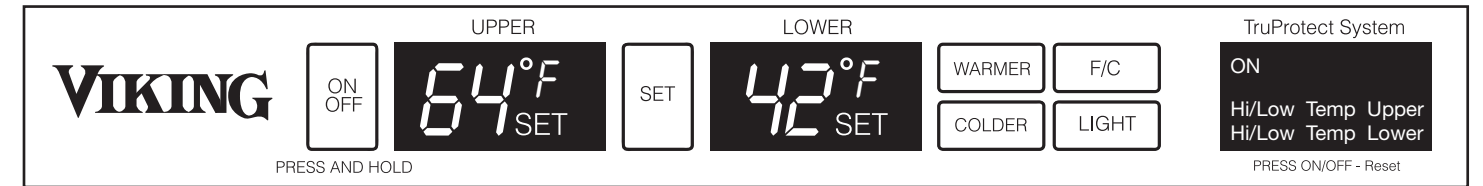

Control Confirmation/Comment				
Service Diagnostics Mode enables service technicians to identify the firmware and software versions, test status of “model specific” system components and sensors and change state of components where applicable, (i.e. - compressor on/off, etc...). While in Service Diagnostics Mode, tests are incremented by pressing the <b>SET</b> keypad and specific component states can be changed to “ON” and “OFF” by pressing the <b>WARMER</b> and <b>COLDER</b> keypads respectively. The following component tests are available:				
			<u>Available Status Indicators</u>	
Test #	Component Description	OK	Off/Open	On/Shorted
0	Temp Sensor, Upper	0-	00	01
1	Temp Sensor, Lower	1-	10	11
2	Compressor	n/a	20	21
3	Condenser Fan	n/a	30	31
4	Compartment Fan, Upper	n/a	40	41
5	Compartment Fan, Lower	n/a	50	51
6	Heater/Fan Assembly, Upper	n/a	60	61
7	Heater/Fan Assembly, Lower	n/a	70	71
8	Door Sense	n/a	80	81
<b>NOTE:</b> The Door Sense is located between the Upper Compartment display and the ON/OFF key and can be tested with any magnet.				

## SERVICE INFORMATION

If service is required, call your dealer or authorized service agency. The name of the authorized service agency can be obtained from the dealer or distributor in your area.

Have the following information readily available.

- Model number
- Serial number
- Date purchased
- Name of dealer from whom purchased

Clearly describe the problem that you are having. If you are unable to obtain the name of an authorized service agency, or if you continue to have service problems, contact Viking Range Corporation at 1-888-VIKING1 (845-4641), or write to:

**VIKING RANGE CORPORATION  
PREFERRED SERVICE  
1803 Hwy 82W  
Greenwood, Mississippi 38930 USA**

Record the information indicated below. You will need it if service is ever required. The model and serial number for your wine cellar are located on the front of the unit at the base of the door frame.

Model Number \_\_\_\_\_ Serial Number \_\_\_\_\_

Date of Purchase \_\_\_\_\_ Date Installed \_\_\_\_\_

Dealer's Name \_\_\_\_\_

Address \_\_\_\_\_

If service requires installation of parts, use only authorized parts to insure protection under the warranty.

**KEEP THIS MANUAL FOR FUTURE REFERENCE.**

## UNDERCOUNTER/FREESTANDING WINE CELLAR WARRANTY (Units Certified for Indoor Use)

### TWO YEAR FULL WARRANTY

Built-In/Freestanding Undercounter Wine Cellars and all of their components and accessories, except as detailed below, are warranted to be free from defects in material or workmanship under normal household use for a period of two (2) years from the date of original retail purchase. Viking Range Corporation, warrantor, agrees to repair or replace, at its option, any part which fails or is found to be defective during the warranty period.

\*Painted and decorative items are warranted to be free from defective materials or workmanship for a period of ninety (90) days from the date of original retail purchase. ANY DEFECTS MUST BE REPORTED TO THE SELLING DEALER WITHIN NINETY (90) DAYS FROM DATE OF ORIGINAL RETAIL PURCHASE.

### SIX YEAR FULL WARRANTY

Any sealed refrigeration system component, as listed below, is warranted to be free from defective materials or workmanship in normal household use during the third through the sixth year from the date of original retail purchase. Viking Range Corporation, warrantor, agrees to repair or replace, at its option, any part which fails or is found to be defective during the warranty period.

#### Sealed Refrigeration System Components:

Compressor, Evaporator,  
Condenser, Connecting Tubing, Dryer/Strainer

### TWELVE YEAR LIMITED WARRANTY

Any sealed refrigeration system component, as listed above, which fails due to defective materials or workmanship in normal household use during the seventh through the twelfth year from the date of original retail purchase will be repaired or replaced, free of charge for the part itself, with the owner paying all other costs, including labor.

**NINETY (90) DAY RESIDENTIAL PLUS WARRANTY** This warranty applies to applications where use of the product extends beyond normal residential use. Examples are, but not limited to, bed and breakfasts, fire stations, private clubs, churches, etc. This warranty excludes all commercial locations such as restaurants, food service locations and institutional food service locations.

This warranty extends to the original purchaser of the product warranted hereunder and to each transferee owner of the product during the term of the warranty.

This warranty shall apply to products purchased and located in the United States and Canada. Products must be purchased in the country where service is requested. Warranty labor shall be performed by an authorized Viking Range Corporation service agency or representative. Warranty shall not apply to damage resulting from abuse, accident, natural disaster, loss of electrical power to the product for any reason, alteration, improper installation, improper operation or repair or service to the product by anyone other than an authorized Viking Range Corporation service agency or representative. Warranty shall not apply to damage resulting from indoor units being used in outdoor situations. This warranty does not apply to commercial usage. Warrantor is not responsible for consequential or incidental damage whether arising out of breach of warranty, breach of contract, or otherwise. Some jurisdictions do not allow the exclusion or limitation of incidental or consequential damages, so the above limitation or exclusion may not apply to you.

Owner shall be responsible for proper installation, providing normal care and maintenance, providing proof of purchase upon request, and making the appliance reasonably accessible for service. If the product or one of its component parts contains a defect or malfunction during the warranty period, after a reasonable number of attempts by the warrantor to remedy the defects or malfunctions, the owner is entitled to either a refund or replacement of the product or its component part or parts. Replacement of a component part includes its free installation. Warrantor's liability on any claim of any kind, with respect to the goods or services covered hereunder, shall in no case exceed the price of the goods or service or part there of which gives rise to the claim.

**WARRANTY SERVICE:** Under the terms of this warranty, service must be performed by a factory authorized Viking Range Corporation service agent or representative. Service will be provided during normal business hours, and labor performed at overtime or premium rates shall not be covered by this warranty. To obtain warranty service, contact the dealer from whom the product was purchased, an authorized Viking Range Corporation service agent, or Viking Range Corporation. Provide model and serial number and date of original purchase. For the name of your nearest authorized Viking Range Corporation service agency, call the dealer from whom the product was purchased or Viking Range Corporation. **IMPORTANT:** Retain proof of original purchase to establish warranty period.

The return of the Owner Registration Card is not a condition of warranty coverage. You, however, should return the Owner Registration Card so that Viking Range Corporation can contact you should any question of safety arise which could affect you.

Any implied warranties of merchantability and fitness applicable to the above described undercounter wine cellar are limited in duration to the period of coverage of the applicable express written limited warranties set forth above. Some jurisdictions do not allow limitations on how long an implied warranty lasts, so the above limitation may not apply to you. This warranty gives you specific rights, and you may also have other rights which may vary from jurisdiction to jurisdiction.

Specifications subject to change without notice.

## UNDERCOUNTER/FREESTANDING WINE CELLAR WARRANTY (Units Certified for Outdoor Use)

### ONE YEAR FULL WARRANTY

Built-In/Freestanding Undercounter Wine Cellars and all of their components and accessories, except as detailed below\*, are warranted to be free from defects in material or workmanship under normal household use for a period of one (1) year from the date of original retail purchase. Viking Range Corporation, warrantor, agrees to repair or replace, at its option, any part which fails or is found to be defective during the warranty period.

\*Painted and decorative items are warranted to be free from defective materials or workmanship for a period of ninety (90) days from the date of original retail purchase. ANY DEFECTS MUST BE REPORTED TO THE SELLING DEALER WITHIN NINETY (90) DAYS FROM DATE OF ORIGINAL RETAIL PURCHASE.

### FIVE YEAR LIMITED WARRANTY

Any sealed refrigeration system component, as listed below, is warranted to be free from defective materials or workmanship in normal household use during the second through the fifth year from the date of original retail purchase. Viking Range Corporation, warrantor, agrees to repair or replace, at its option, any part which fails or is found to be defective during the warranty period.

**Sealed Refrigeration System Components:** Compressor, Evaporator, Condenser, Connecting Tubing, Dryer/Strainer

It is recommended that in temperatures above 100°F (37.8°C) and below 40°F (4.4°C) the unit be shut off. The normal operating range for the unit is between 60°F (15.6°F) and 100°F (37.8°C).

**NINETY (90) DAY RESIDENTIAL PLUS WARRANTY** This warranty applies to applications where use of the product extends beyond normal residential use. Examples are, but not limited to, bed and breakfasts, fire stations, private clubs, churches, etc. This warranty excludes all commercial locations such as restaurants, food service locations and institutional food service locations.

This warranty extends to the original purchaser of the product warranted hereunder and to each transferee owner of the product during the term of the warranty.

This warranty shall apply to products purchased and located in the United States and Canada. Products must be purchased in the country where service is requested. Warranty labor shall be performed by an authorized Viking Range Corporation service agency or representative. Warranty shall not apply to damage resulting from abuse, accident, natural disaster, loss of electrical power to the product for any reason, alteration, improper installation, improper operation or repair or service to the product by anyone other than an authorized Viking Range Corporation service agency or representative. Warranty shall not apply to damage resulting from indoor units being used in outdoor situations. This warranty does not apply to commercial usage. Warrantor is not responsible for consequential or incidental damage whether arising out of breach of warranty, breach of contract, or otherwise. Some jurisdictions do not allow the exclusion or limitation of incidental or consequential damages, so the above limitation or exclusion may not apply to you.

Owner shall be responsible for proper installation, providing normal care and maintenance, providing proof of purchase upon request, and making the appliance reasonably accessible for service. If the product or one of its component parts contains a defect or malfunction during the warranty period, after a reasonable number of attempts by the warrantor to remedy the defects or malfunctions, the owner is entitled to either a refund or replacement of the product or its component part or parts. Replacement of a component part includes its free installation. Warrantor's liability on any claim of any kind, with respect to the goods or services covered hereunder, shall in no case exceed the price of the goods or service or part there of which gives rise to the claim.

**WARRANTY SERVICE:** Under the terms of this warranty, service must be performed by a factory authorized Viking Range Corporation service agent or representative. Service will be provided during normal business hours, and labor performed at overtime or premium rates shall not be covered by this warranty. To obtain warranty service, contact the dealer from whom the product was purchased, an authorized Viking Range Corporation service agent, or Viking Range Corporation. Provide model and serial number and date of original purchase. For the name of your nearest authorized Viking Range Corporation service agency, call the dealer from whom the product was purchased or Viking Range Corporation. **IMPORTANT:** Retain proof of original purchase to establish warranty period.

The return of the Owner Registration Card is not a condition of warranty coverage. You, however, should return the Owner Registration Card so that Viking Range Corporation can contact you should any question of safety arise which could affect you.

Any implied warranties of merchantability and fitness applicable to the above described undercounter refrigerated beverage center are limited in duration to the period of coverage of the applicable express written limited warranties set forth above. Some jurisdictions do not allow limitations on how long an implied warranty lasts, so the above limitation may not apply to you. This warranty gives you specific rights, and you may also have other rights which may vary from jurisdiction to jurisdiction.

Specifications subject to change without notice.