

SCFU285

20.75" x 22.5" x 21.0" (H x W x D)

Commercially approved countertop impulse freezer with glass door, front lock, and self-closing door

Highlights:

Self-closing glass door saves energy and provides maximum visibility

Full fluorescent light illuminates items for a tempting view

Compact size perfect for placement above counters

Commercially approved for use in foodservice establishments



Commercially approved	ETL-S Listed to ANSI-NSF Standard 7 and CalCode Compliant
Compact dimensions	Sized for placement on top of counters
Glass door	Display products behind a solid glass door for an easy and tempting view
Wrap-around cooling	Frozen food stays frozen with a stable cold temperature throughout the freezer
Manual defrost	No temperature fluctuations with an energy efficient manual defrost system
Self-closing door	Save energy with a door that stays closed after use
Front-mounted lock	Keep contents secure with a key lock on the door
Full fluorescent lighting	Rear rocker switch controls this tube lamp for full interior lighting
Adjustable thermostat	Adjust the temperature using a screwdriver or tool on the back of the unit to prevent accidental temperature changes
Cantilevered shelves	Rearrange your freezer space to accommodate all shapes and sizes or remove shelves for a simple clean-up

Specifications:

Height	20.75"
Width	22.5"
Depth	21.0"
Interior Height 1	15.0"
Interior Width 1	17.75"
Interior Depth 1	16.5"
Comp Step Height	9.25"
Comp Step Width	8.25"
Comp Step Depth	17.75"
Shipping Weight	95.0 lbs.
Amps	2.1
Voltage/Frequency	115 V AC/60 Hz
Canadian Electrical Safety	ETL-C
US Electrical Safety	ETL
Door Swing	RHD
Reversible	No
Shelf Quantity	2
Adjustable Shelf	true
Shelf Type	Wire
Defrost Type	Manual
Depth with door at 90°	42.0"
Height to Hinge Cap	21.25"
Light	true
Thermostat Type	Dial
Condensor Location	Rear of Unit
Low Side PSI	105.0
Level Legs Quantity	4
High Side PSI	220.0
Freon Type	R134a
Freon Oz	3.88
Compressor Warranty	5 Years
Parts/Labor Warranty	1 Year
Sanitation	ETL-S

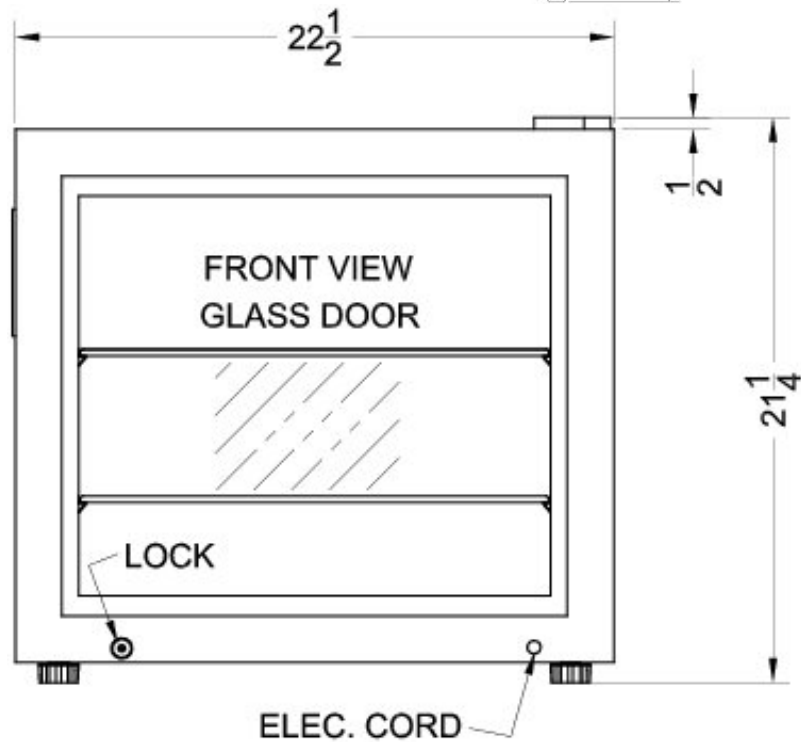
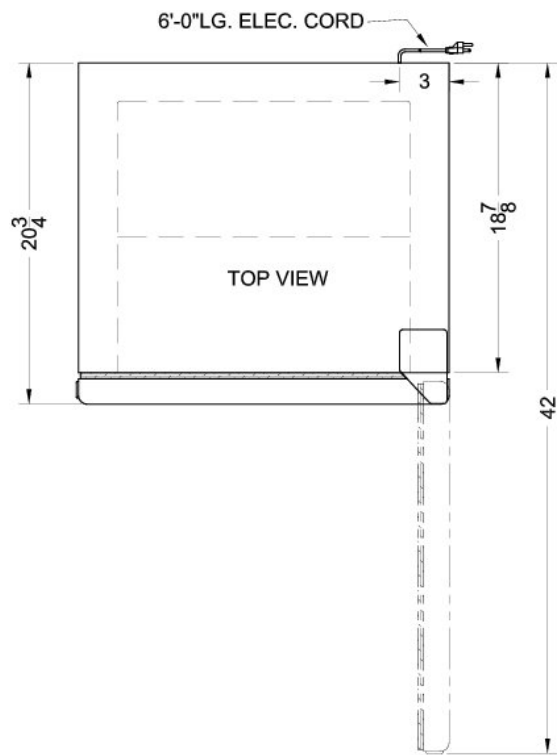

Summit Appliance Division, Felix Storch, Inc.
 770 Garrison Ave • Bronx, NY 10474
 Phone: 718-893-3900 • Fax: 718-842-3093
 Email: info@summitappliance.com