

CM420ES

33.38" x 19.5" x 21.25" (H x W x D)

ENERGY STAR qualified compact refrigerator-freezer in white, under 20 inches wide with front lock

Highlights:

ENERGY STAR qualified for higher efficiency and lower utility bills

Under 20 inches wide to fit even the tightest space

Factory-installed lock provides security you can count on

Door shelves and a clear crisper provide easy storage solutions



ENERGY STAR qualified	Rated to perform with more efficiency than federal standards require, using less energy and saving on utility bills
Thin-line design	Limited space is no problem for our thin-line models, designed specifically for those hard-to-fit spots
Factory installed lock	Keep contents secure with a key lock on the door
Clear crisper	Get the longest life and best taste out of produce by storing it in a convenient slide drawer
Door storage	Store large bottles right on the door for easy access
Two can dispensers	Stack cans for an easy grab in two handy door compartments
Adjustable shelves	Rearrange your refrigerator space to accommodate all shapes and sizes or remove shelves for a simple clean-up
Reversible door	Keep your options flexible with a reversible door that's easy to switch when your arrangement changes
Adjustable thermostat	Control your food's temperature with ease and accuracy
Manual defrost operation	Energy efficient operation for stable interior temperature

Specifications:

Height	33.38"
Width	19.5"
Depth	21.25"
Capacity	4.1 cu.ft.
Interior Height 1	22.0"
Interior Width 1	17.0"
Interior Depth 1	15.63"
Interior Height 2	7.5"
Interior Width 2	15.13"
Interior Depth 2	9.75"
Comp Step Height	8.0"
Comp Step Width	17.0"
Comp Step Depth	4.5"
Shipping Weight	80.0 lbs.
Amps	1.4
Canadian Electrical Safety	ULC
Energy Usage/Year	270.0 kWh/year
Voltage/Frequency	115 V AC/60 Hz
US Electrical Safety	UL
Door Swing	RHD
Reversible	Yes
Crisper Quantity	1
Shelf Quantity	2
Adjustable Shelf	true
Shelf Type	Wire
Crisper Cover Type	Glass
Crisper Finish	Transparent
Full Door Shelf Quantity	1
Can Storage	true
Defrost Type	Manual
Depth with door at 90°	39.63"
Height to Hinge Cap	33.75"
Thermostat Type	Dial
Condensor Location	Rear of Unit
Freon Oz	2.1
Freon Type	R134a
Level Legs Quantity	2
High Side PSI	238.0
Low Side PSI	103.0
Parts/Labor Warranty	1 Year
Compressor Warranty	5 Years

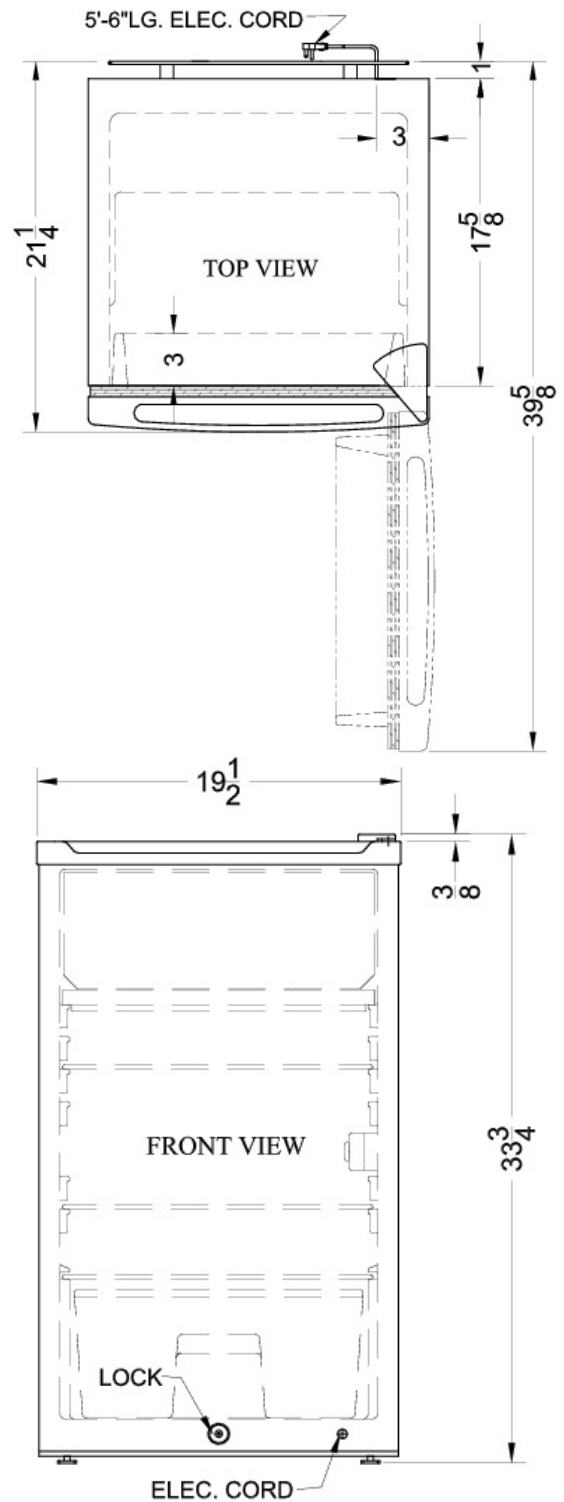

Summit Appliance Division, Felix Storch, Inc.
 770 Garrison Ave • Bronx, NY 10474
 Phone: 718-893-3900 • Fax: 718-842-3093
 Email: info@summitappliance.com