

ALB651

32.0" x 23.63" x 23.5" (H x W x D)

ADA compliant refrigerator-freezer for built-in undercounter use, with cycle defrost, white cabinet, and customizable door for overlay or slide-in panels

Highlights:

32 inch ADA compliant height fits under counters

Perfectly sized to fit in tight 24 inch spaces

Match your unit to its setting by customizing the door with a slide-in or full overlay panel

Flexible design allows built-in or freestanding use

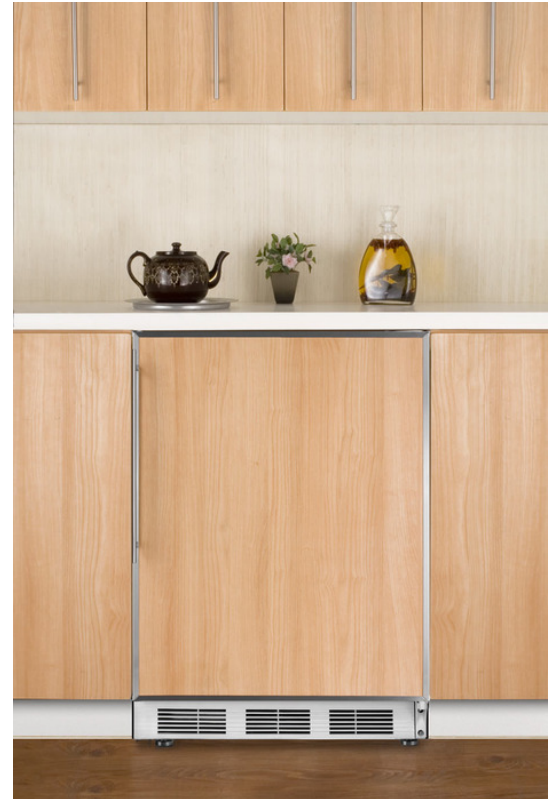

ADA compliant	32 inch height fits under standard ADA counters
Built-in capable	Make the best use of space by installing your refrigerator under the counter and flush with other cabinets
Fully finished white cabinet	Allows the refrigerator-freezer to be used as a freestanding model
Customizable door front	Choose option "IF" for our integrated door frame to mount full overlay panels over the door, or our "FR" option for a two-piece stainless steel frame with handle that accepts slide-in panels
Cycle defrost	Combines an automatic defrosting refrigerator with a manual defrosting freezer to save energy but protect food
Dual evaporator	SUMMIT's unique and efficient design separately cools the refrigerator while maintaining zero degrees in the freezer with two evaporators
Zero degree freezer	Keep ice cream frozen and freezer burn-free in a freezer that reaches and maintains zero degrees
Adjustable thermostat	Control your food's temperature with ease and accuracy
Interior light	Automatically illuminates when you open the door
Adjustable shelves	Rearrange your refrigerator space to accommodate all shapes and sizes or remove shelves for a simple clean-up

Specifications:

Height	32.0"
Width	23.63"
Depth	23.5"
Capacity	5.1 cu.ft.
Ext Depth with Handle	25.13"
Interior Height 1	19.5"
Interior Width 1	20.5"
Interior Depth 1	17.0"
Interior Height 2	5.0"
Interior Width 2	19.0"
Interior Depth 2	11.5"
Comp Step Height	7.0"
Comp Step Width	20.5"
Comp Step Depth	5.0"
Shipping Weight	107.0 lbs.
Weight	100.0 lbs.
Canadian Electrical Safety	ULC
US Electrical Safety	UL
Voltage/Frequency	115 V AC/60 Hz
Energy Usage/Year	434.0 kWh/year
Amps	1.3
Door Swing	RHD
Reversible	Yes
Crisper Quantity	1
Shelf Quantity	3
Adjustable Shelf	true
Shelf Type	Wire
Crisper Cover Type	Glass
Crisper Finish	Transparent
Full Door Shelf Quantity	3
Defrost Type	Cycle
Depth with door at 90°	45.63"
Height to Hinge Cap	32.25"
Fan Type	Exterior
Thermostat Type	Dial
Light	true
Condensor Location	Rear of Unit
High Side PSI	285.0
Level Legs Quantity	4
Freon Oz	2.6
Freon Type	R134a
Low Side PSI	70.0
Parts/Labor Warranty	1 Year
Compressor Warranty	5 Years

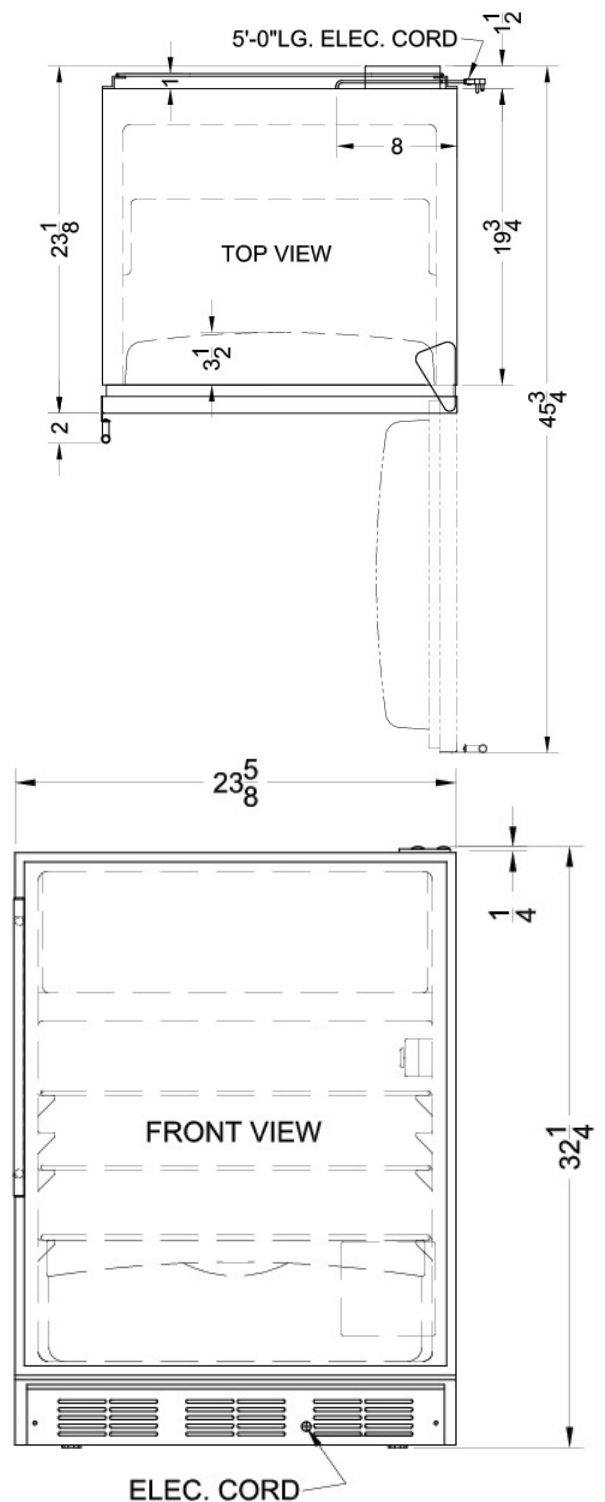

Summit Appliance Division, Felix Storch, Inc.
 770 Garrison Ave • Bronx, NY 10474
 Phone: 718-893-3900 • Fax: 718-842-3093
 Email: info@summitappliance.com