

FS20LGL7CSSVK

20.75" x 19.75" x 21.0" (H x W x D)

Commercially approved glass door stainless steel vodka freezer in compact size

Highlights:

- Commercially approved for use in foodservice establishments
- Factory-installed lock provides security you can count on
- Glass door highlights collection
- Stainless steel cabinet adds durable luxury to any setting



Commercially approved	ETL-S Approved to ANSI-NSF Standard 7 and CalCode Compliant
Compact dimensions	Square footprint for placement on top of counters
Fully wrapped stainless steel cabinet	Allows the unit to be used freestanding
Glass door	Display your collection with unique style
Ceiling racks	Hang martini glasses for a luxurious look
Front-mounted lock	Keep contents secure with a key lock on the door
Manual defrost	No temperature fluctuations with an energy efficient manual defrost system
Fluorescent lighting	Illuminate your collection by switching on the interior light
100% CFC free	Environmentally friendly design without ozone-damaging chemicals

Specifications:

Height	20.75"
Width	19.75"
Depth	21.0"
Capacity	1.6 cu.ft.
Interior Height 1	14.5"
Interior Width 1	15.5"
Interior Depth 1	15.0"
Comp Step Height	8.5"
Comp Step Width	15.5"
Comp Step Depth	7.0"
Shipping Weight	68.0 lbs.
US Electrical Safety	UL
Energy Usage/Year	277.0 kWh/year
Amps	1.43
Voltage/Frequency	115 V AC/60 Hz
Canadian Electrical Safety	ULC
Door Swing	RHD
Reversible	No
Shelf Quantity	1
Adjustable Shelf	true
Defrost Type	Manual
Depth with door at 90°	38.0"
Height to Hinge Cap	20.0"
Light	true
Thermostat Type	Dial
Condensor Location	Rear of Unit
Low Side PSI	88.0
Level Legs Quantity	2
High Side PSI	250.0
Freon Type	R134a
Freon Oz	3.17
Compressor Warranty	5 Years
Parts/Labor Warranty	1 Year
Sanitation	NSF

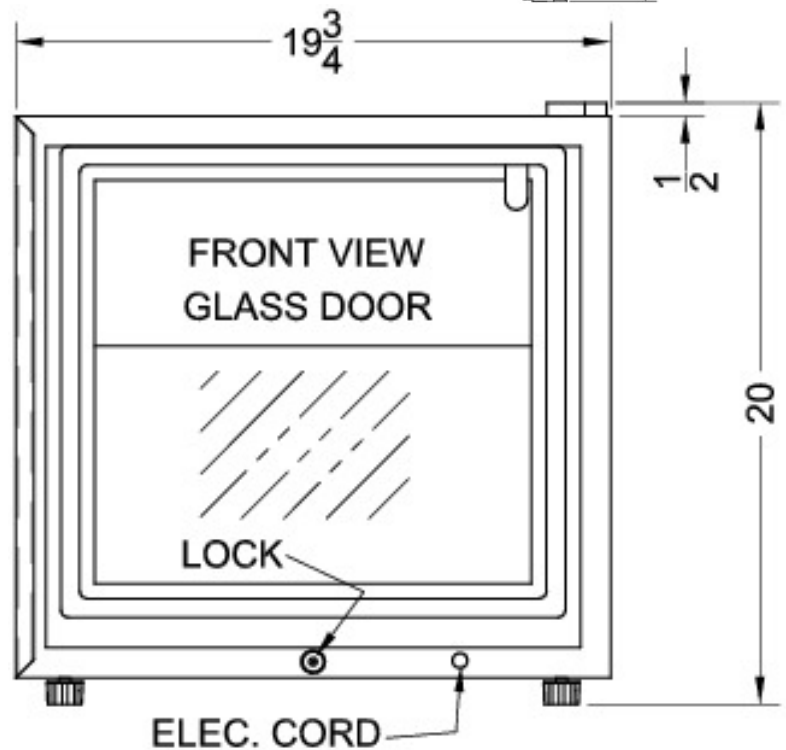
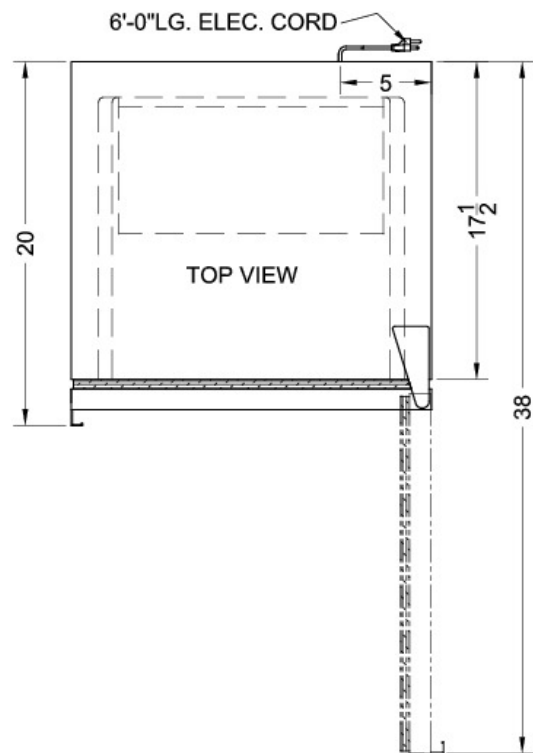

Summit Appliances Division, Felix Storch, Inc.
 770 Garrison Ave • Bronx, NY 10474
 Phone: 718-893-3900 • Fax: 718-842-3093
 Email: info@summitappliance.com