



Stainless



Overlay

## 2175WCC

**2000 SERIES**

### FEATURES

**PERFORMANCE**

- Wine bottle capacity of up to 48 bottles (.75L)
- Touch glass digital control featuring easy view command center manages key functions and provides user alerts such as an audible door open alarm
- Digital controlled single-zone convection cooling system provides a stable and consistent environment for optimum wine storage
- Temperature setting from 38 to 60° F allows for controlled storage of any wine varietal
- Convection cool technology and concealed evaporator create quicker chill down time
- Sabbath / Blackout mode turns off all lighting and controls display and automatically resets after 36 hours
- ENERGY STAR® / CEE Tier 1 rated makes this the first ever ENERGY STAR® wine preservation unit
- UL residential and commercial listings

**INTERIOR / EXTERIOR**

- Lighted black interior optimizes elegant display of wines and can be manually turned on for display with door closed; automatically shuts off after four hours
- Solid beech wood trimmed, full extension black vinyl coated wine racks allow for full access to stored wines and lower display rack allows for elegant wine presentation
- Standard commercial stainless steel handle is interchangeable with professional handle option on stainless steel model
- Self-closing door ensures a positive door seal and prevents door bounce back
- Full wrap stainless door on stainless model must be ordered right or left hand hinged
- LowE coated, argon gas filled thermopane glass door provides protection from potentially harmful UV rays and added insulating energy efficiency
- Overlay model door is field reversible
- Black vinyl clad textured cabinet is more resistant to scratching, peeling and flaking

**INTEGRATION**

- Solid beech wood trim on wine racks can be stained to match surrounding cabinetry
- Unit can be built-in or freestanding providing a custom aesthetic
- Overlay model accepts a full 3/4" overlay frame and can be fully integrated into all styles of cabinetry with zero clearance
- Allow a 2-1/2" clearance on hinged side for 90° door opening when installed adjacent to a wall (for stainless steel model)
- Allow 1/4" width overall for proper installation (see backside for details)
- No additional clearance around sides, top or rear of unit is needed for ventilation
- Durable, factory installed level legs provide a more precise undercounter fit
- Do not obstruct front grille air flow

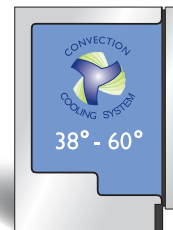

Single Zone Convection Cooling System featured in 2175WCC.



For elegant presentation of your wine collection, all U-Line Wine Captain® Models have an illuminated interior.



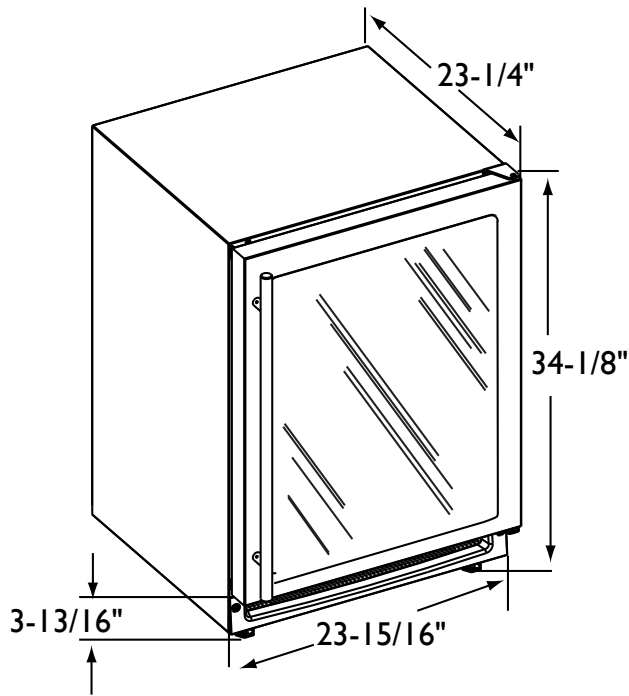

2175WCS Stainless Model

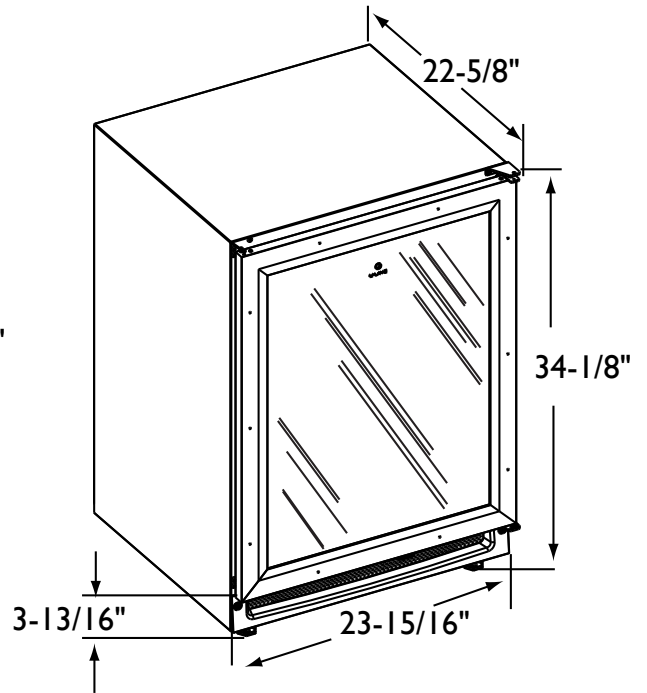

2175WCOL Overlay Model

\* Not including wood overlay frame

DIMENSIONS AND SPECIFICATIONS

OVERALL DIMENSIONS

Height	34-1/8" (86.6)
Width	23-15/16" (60.8)
Depth	23-1/4" (59.1)
With stainless steel handle	25-1/8" (63.8)
Shipping weight:	
Overlay model	144 lbs (65.4 kg)
Stainless model	144 lbs (65.4 kg)
Running amps	2.4
Maximum start-up amps	9.8
Amps pertain to voltage rating	110/115 volt, 60 Hz
ENERGY STAR® and CEE Tier I	

Capacities:	
Wine bottle storage (0.75L)	Up to 48

2175WCC

Stainless Right-hand	U-2175WCS-00
Stainless Left-hand	U-2175WCS-01
Overlay	U-2175WCOL-00

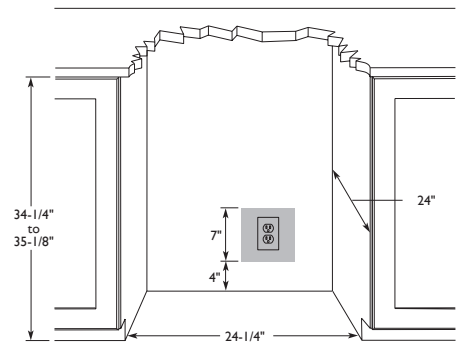

Please visit [www.u-line.com](http://www.u-line.com) for installation guide.  
All specifications are subject to change without notice.

