

PLANNING GUIDE  
GAS COOKTOPS

# GAS COOKTOPS

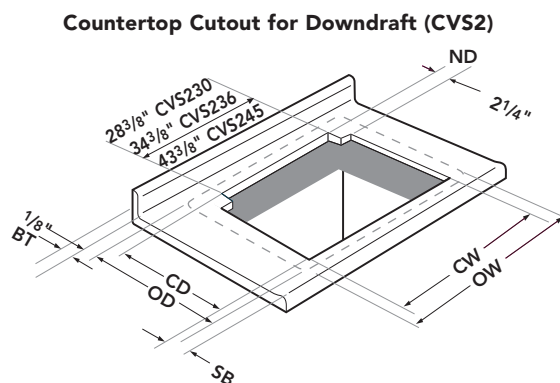
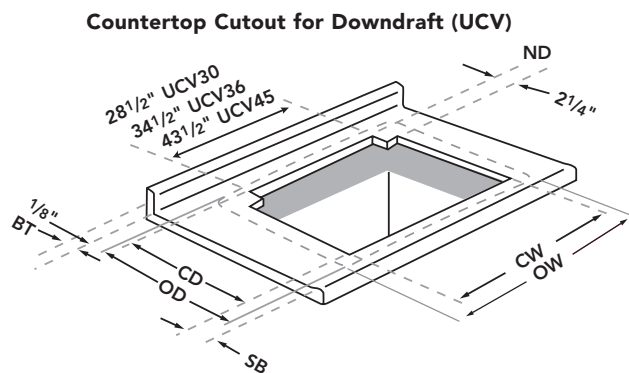
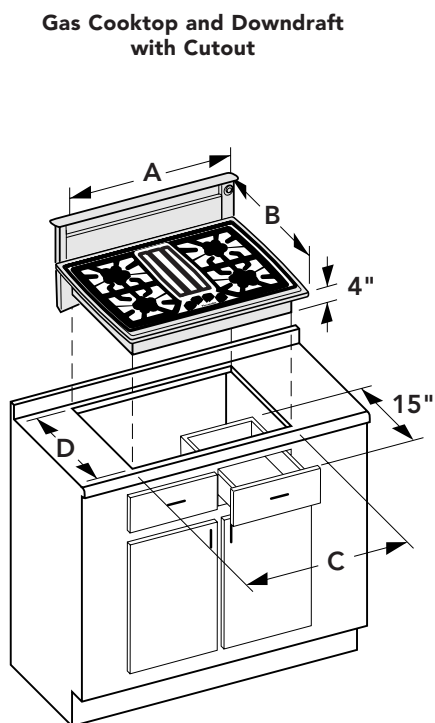

Model No.	Overall Dimensions		Cutout Dimensions*		Front		Burner BTU/hr Output		Center			
	A	B	C	D	Left	Right	Left	Right	Left	Right		
<b>Gas Cooktop Cutouts</b>												
SGSX304C	31	21 <sup>1</sup> / <sub>2</sub>	28 <sup>15</sup> / <sub>16</sub>	29 <sup>3</sup> / <sub>8</sub>	19 <sup>1</sup> / <sub>8</sub>	19 <sup>7</sup> / <sub>8</sub>	200-8,000	1,650-12,000	300-12,000	950-8,000	N/A	N/A
SGS304C	31	21 <sup>1</sup> / <sub>2</sub>	28 <sup>15</sup> / <sub>16</sub>	29 <sup>3</sup> / <sub>8</sub>	19 <sup>1</sup> / <sub>8</sub>	19 <sup>7</sup> / <sub>8</sub>	950-8,000	1,650-12,000	1,650-12,000	950-8,000	N/A	N/A
SGSX365C	37	21 <sup>1</sup> / <sub>2</sub>	34 <sup>15</sup> / <sub>16</sub>	35 <sup>3</sup> / <sub>8</sub>	19 <sup>1</sup> / <sub>8</sub>	19 <sup>7</sup> / <sub>8</sub>	200-8,000	1,650-12,000	300-12,000	950-8,000	2,150-15,000	N/A
SGS365C	37	21 <sup>1</sup> / <sub>2</sub>	34 <sup>15</sup> / <sub>16</sub>	35 <sup>3</sup> / <sub>8</sub>	19 <sup>1</sup> / <sub>8</sub>	19 <sup>7</sup> / <sub>8</sub>	950-8,000	1,650-12,000	1,650-12,000	950-8,000	2,150-15,000	N/A
SGSX456C	46	21 <sup>1</sup> / <sub>2</sub>	43 <sup>15</sup> / <sub>16</sub>	44 <sup>1</sup> / <sub>2</sub>	19 <sup>1</sup> / <sub>8</sub>	19 <sup>7</sup> / <sub>8</sub>	200-8,000	1,650-12,000	300-12,000	950-8,000	2,150-15,000	2,150-15,000

Model No.	CW Cutout Width		CD Cutout Depth		OW Overall Width		OD Overall Depth		SB Minimum Set Back		BT Maximum Back Splash		ND Notch Depth	
	CVS2	UCV	CVS2	UCV	CVS2	UCV	CVS2	UCV	CVS2	UCV	CVS2	UCV	CVS2	UCV
<b>Comprehensive Countertop Cutout with Downdraft</b>														
SGS304C, SGSX304C	28 <sup>15</sup> / <sub>16</sub>	28 <sup>15</sup> / <sub>16</sub>	22 <sup>1</sup> / <sub>4</sub>	22 <sup>1</sup> / <sub>4</sub>	31	31	23 <sup>3</sup> / <sub>4</sub>	23 <sup>3</sup> / <sub>4</sub>	11 <sup>1</sup> / <sub>2</sub>	11 <sup>1</sup> / <sub>2</sub>	3/4	3/4	2 <sup>1</sup> / <sub>4</sub>	2 <sup>1</sup> / <sub>4</sub>
SGS365C, SGSX365C	34 <sup>15</sup> / <sub>16</sub>	34 <sup>15</sup> / <sub>16</sub>	22 <sup>1</sup> / <sub>4</sub>	22 <sup>1</sup> / <sub>4</sub>	37	37	23 <sup>3</sup> / <sub>4</sub>	23 <sup>3</sup> / <sub>4</sub>	11 <sup>1</sup> / <sub>2</sub>	11 <sup>1</sup> / <sub>2</sub>	3/4	3/4	2 <sup>1</sup> / <sub>4</sub>	2 <sup>1</sup> / <sub>4</sub>
SGSX456C	43 <sup>15</sup> / <sub>16</sub>	43 <sup>15</sup> / <sub>16</sub>	22 <sup>1</sup> / <sub>4</sub>	22 <sup>1</sup> / <sub>4</sub>	46	46	23 <sup>3</sup> / <sub>4</sub>	23 <sup>3</sup> / <sub>4</sub>	11 <sup>1</sup> / <sub>2</sub>	11 <sup>1</sup> / <sub>2</sub>	3/4	3/4	2 <sup>1</sup> / <sub>4</sub>	2 <sup>1</sup> / <sub>4</sub>

## General Information

MODEL NUMBER	SGSX304C	SGS304C	SGSX365C	SGS365C	SGSX456C
60 Hz, Single Phase A.C.:	■	■	■	■	■
120V, 3 Wire, 20 Amps	■	■	■	■	■
Approx. Shipping Weight (lbs.)	45	45	49	49	58

Notes: 1) All height, width and depth dimensions are shown in inches. 2) Solid surface countertops require special cutout size.

\*Please refer to installation instructions prior to making cutout. Installation instructions are available at [www.thermador.com](http://www.thermador.com).



Cooktops are CGA and AGA approved.