

outdoor Liberty Collection



All-Grill Unit



BFG-30G 30" All-Grill with optional cart, side shelves, wood inserts and back bar

The All-Grill unit of the Liberty Collection is a fully featured grill, which delivers professional performance and delicious results. Precision ported, U-shaped 304 grade stainless steel burners rated at 25,000 BTU's per burner offer powerful performance and control.

Our patented Grease Management System® reduces flare-ups by effectively channeling oil and grease away from the flame while grilling. A 9-volt Battery Ignition ensures safe and efficient grill lighting every time and Double-Sided Cast 304 Grade Stainless Steel Grilling Grates feature one side with a gentle radius for support and handling while the other side is W-shaped for maximum grease capture while leaving perfect sear lines. Ceramic Radiant Technology provides intense, even heat.

ADDITIONAL FEATURES

- Large 525 sq. in. grilling surface
- Sear setting
- Patented Grease Management System® reduces flare-ups
- Ceramic Radiant Technology ensures a completely evenly heated cooking surface
- 2 x 25,000 BTU burners
- Flat stainless steel cover included

All-Grill Dimensions (with optional grill cart)

Grill Model: BFG-30G

Cart Model: CAD-30 (shown with optional side shelves)

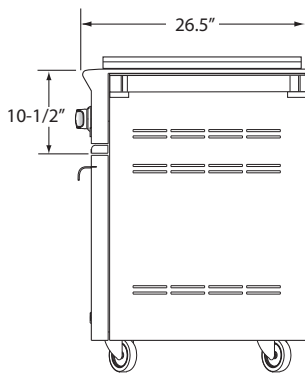
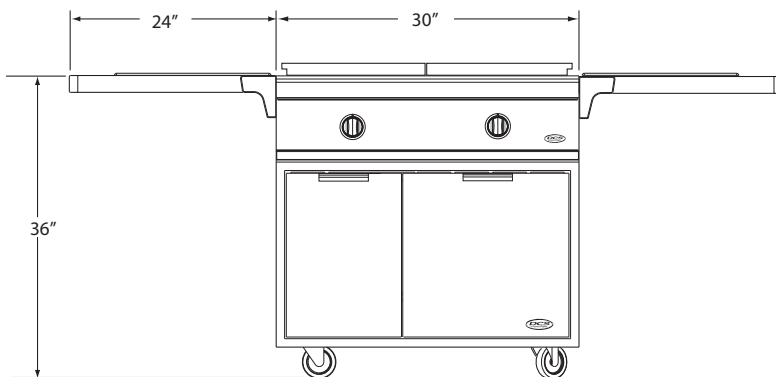

| MODEL NUMBER | BFG-30BG |
|---|-------------------|
| TOTAL COOKING AREA | 525 SQ. INCHES |
| GRILL BURNERS | 2 @ 25,000 BTU/HR |
| DOUBLE-SIDED GRILL GRATES | STAINLESS STEEL |
| GREASE MANAGEMENT SYSTEM® | ✓ |
| SHIPPING WEIGHT (GRILL HEAD) | 120 LBS. |
| SHIPPING WEIGHT (OPTIONAL CART) | 120 LBS. |
| SHIPPING DIMENSIONS (GRILL HEAD) (HEIGHT X WIDTH X DEPTH) | 32" X 32" X 16" |

All-Grill Island Preparation

Grill Model: BFG-30G

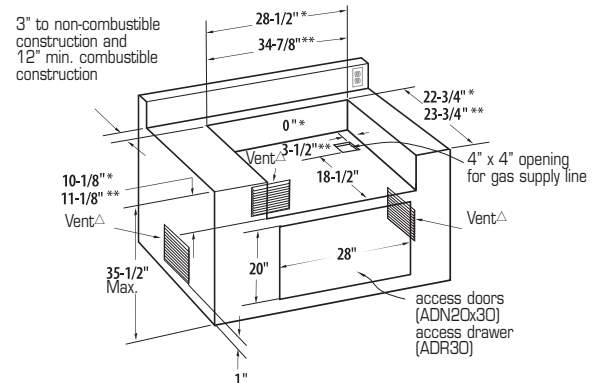

* Standard cut-out dimensions for non-combustible enclosure

** Insulated jacket cut-out dimensions for combustible enclosure

△ Island installation to use minimum of 3 vents providing 10 square inches per vent (typical)

Ordering Data:

Please specify gas type (natural or propane) when ordering

Gas Requirements:

Natural

- 1/2" NPT male with a 3/8" flare adapter
- Operational Pressure: 4" W.C.
- Supply Pressure: 6" to 9" W.C.

Propane

- 1/2" NPT male with a 3/8" flare adapter
- LP hose with a quick disconnect & fitting are shipped connected
- Operational Pressure: 11" W.C.
- Supply Pressure: 11" to 14" W.C.

Power Requirements:

- 9V battery

Island Ventilation Requirements:

It is recommended that adequate ventilation holes must be provided in the base of an enclosure in the event of a gas leak.

Grill Placement:

DO NOT build grill under overhead unprotected combustible construction. Use only in well-ventilated areas. These units are for outdoor use only. If located in a consistently windy area (oceanfront, mountaintop, etc.) a wind break will be required.

Conversion Kits:

NG to LP and LP to NG conversion kits are available from your dealer.

Accessories

- Stainless Steel Grill Cart (CAD-30)
- Single or double side burners for built-in application
- Stainless Steel Access Doors for built-in application
- Stainless Steel Access Drawers for built-in application
- Insulated Jacket for built-in application
- Grilling Tool Set
- Brazilian Cherry Chopping Board that fits in cart optional side-shelf
- Drop-on Griddle Plate
- Vinyl Grill Cover

We encourage you to find out more about these features and learn how they can make your cooking experience more enjoyable by visiting our learning page at: www.dcsappliances.com.

Because of continuing product improvement these specifications are subject to change without notice.