



Stainless

2115RSOD

OUTDOOR SERIES

FEATURES

PERFORMANCE

- 3.0 cubic feet overall capacity maximizes storage
- Touch glass digital control featuring easy view command center manages key functions and provides user alerts such as an audible door open alarm
- Digital controlled single-zone passive cooling system provides a stable and consistent environment for optimum food and beverage storage
- Temperature setting from 34° to 45° provides flexibility for preserving a wide variety of items
- Sabbath / Blackout mode turns off all lighting, controls display and automatically resets after 36 hours
- ENERGY STAR® / CEE Tier I rated
- UL residential, commercial and outdoor listing

INTERIOR / EXTERIOR

- Lighted white interior allows for easy viewing of contents
- Three 4mm full-depth tempered glass shelves with bullnose edge to provide maximum storage potential
- Standard professional stainless steel handle is 1-1/4" diameter and is interchangeable with commercial handle option
- Full wrap stainless door; unit must be ordered right or left hand hinged
- Standard door lock keeps items secure in an outdoor environment
- Full stainless steel cabinet and deemed suitable for outdoor use by UL

INTEGRATION

- Unit can be built-in or freestanding providing a custom aesthetic
- Allow a 2-1/2" clearance on hinged side for 90° door opening when installed adjacent to a wall
- Allow 1/4" width overall for proper installation (see backside for details)
- No additional clearance around sides, top or rear of unit is needed for ventilation
- Durable, factory installed level legs provide a more precise undercounter fit
- Do not obstruct front grille air flow



Durable outdoor units come fully wrapped in stainless with a 1-1/4" diameter professional handle. Refrigerators come standard with a door lock.



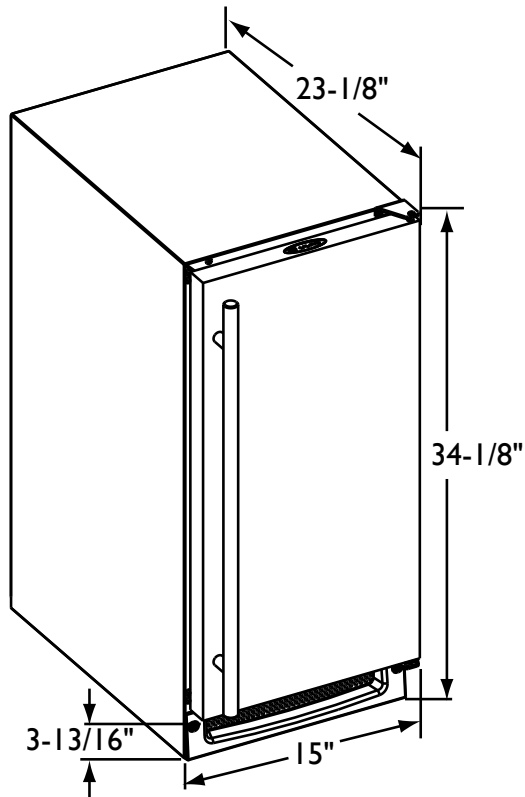

2115RSOD Stainless Model

DIMENSIONS AND SPECIFICATIONS

OVERALL DIMENSIONS

Height	34-1/8" (86.6)
Width	15" (38.1)
Depth	23-1/8" (58.7)
With stainless steel handle	25" (63.5)
Shipping weight:	86 lbs (39 kg)
Running amps	2.4
Maximum start-up amps	9.8
Amps pertain to voltage rating	110/115 volt, 60 Hz
ENERGY STAR® and CEE Tier I	
Capacities:	
Defrost technology	Automatic
Refrigerator volume	3.0 Cu. Ft

2115R

Stainless Left-hand	U-2115RSOD-01
Stainless Right-hand	U-2115RSOD-00

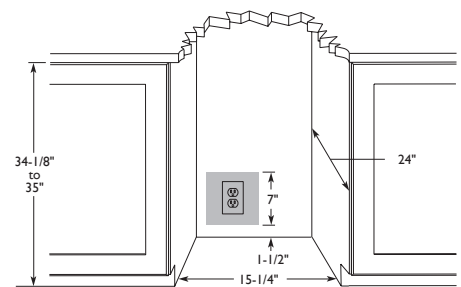

Please visit www.u-line.com for installation guide.

All specifications are subject to change without notice.

