



Stainless



Black



Overlay

2275DWRC

2000 SERIES

FEATURES

PERFORMANCE

- 5.3 cubic feet overall capacity maximizes storage
- Touch glass digital control featuring easy view command center manages key functions and provides user alerts such as an audible drawer open alarm
- Digital controlled convection cooling system provides a stable and consistent environment for optimum food and beverage storage
- Temperature setting from 34 to 45° F can be set independently for each drawer to provide flexibility in preserving a wide variety of items
- Sabbath / Blackout mode turns off all lighting, controls display and automatically resets after 36 hours
- Automatic defrost
- ENERGY STAR® / CEE Tier 2 rated
- UL residential and commercial listings

INTERIOR / EXTERIOR

- Lighted stainless steel drawer interior optimizes easy viewing of contents
- Clear organizing bin in top drawer holds wine, 2-liter bottles and other items and slides back and forth for access to items beneath
- Optional slide & divide organizing system must be ordered separately PN: U-26013
- Convenient crisper drawer for proper storage and humidity control of perishable items can be completely removed for storage of taller items
- Black vinyl clad textured cabinet is more resistant to scratching, peeling and flaking

INTEGRATION

- Due to the full extension of drawers, anchoring device included and required for all installations
- Overlay can be converted to a black model with purchase of a black handle kit P/N: 26070-01
- Overlay model accepts a full 3/4" overlay panel and can be fully integrated into all styles of cabinetry
- Allow 1/4" width overall for proper installation (see backside for details)
- No additional clearance around sides, top or rear of unit is needed for ventilation
- Durable, factory installed level legs provide a more precise undercounter fit
- Do not obstruct front grille air flow

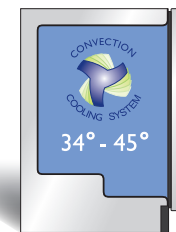

Single Zone Convection Cooling System featured in 2275DWRC.



2275DWRC – Clear top organizer bin accommodates food, wine and two-liter bottles within easy reach while the optional slide and divide organizer adjusts to keep items in place.

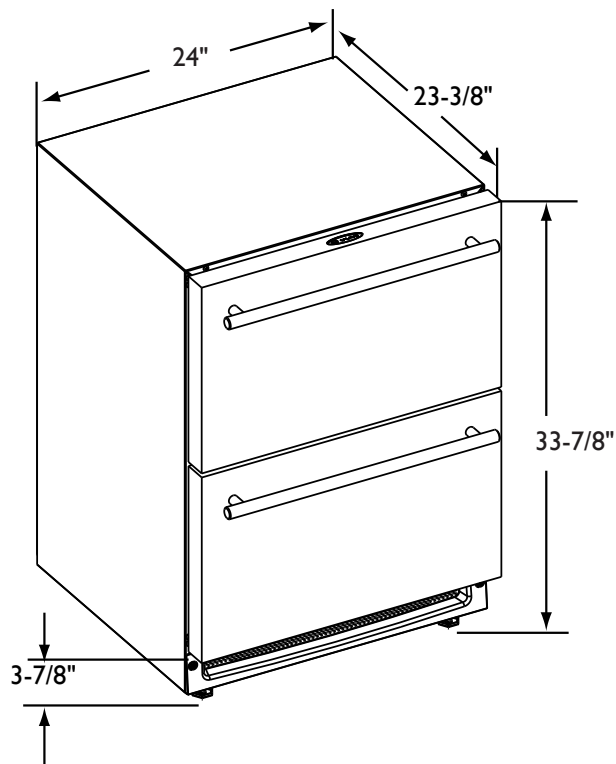

2275DWRCSS Stainless Model

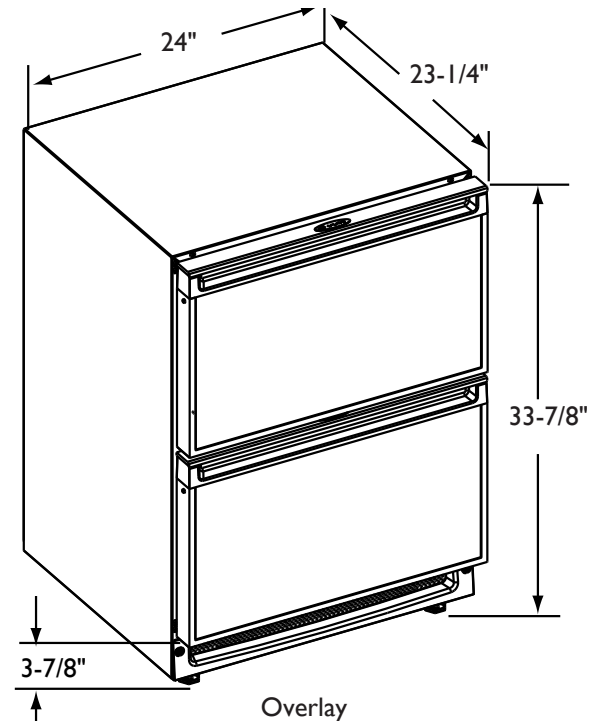

2275DWRCOL Overlay Model

DIMENSIONS AND SPECIFICATIONS

OVERALL DIMENSIONS

| | |
|-----------------------------|----------------|
| Height | 33-7/8" (86.0) |
| Width | 24" (60.8) |
| Depth | 23-1/4" (59.0) |
| With stainless steel handle | 25-1/8" (63.8) |

Shipping weight:

| | |
|--------------------------|-----------------|
| Black and overlay models | 152 lbs (69 kg) |
| Stainless model | 159 lbs (72 kg) |

| | |
|--------------------------------|---------------------|
| Running amps | 2.4 |
| Maximum start-up amps | 6.5 |
| Amps pertain to voltage rating | 110/115 volt, 60 Hz |
| ENERGY STAR® and CEE Tier 2 | |

Capacities:

| | |
|---------------------|------------|
| Refrigerator volume | 5.3 Cu. Ft |
|---------------------|------------|

2275DWRC

| | |
|-----------|--|
| Stainless | U-2275DWRCSS-00 |
| Black | U-2275DWROL-00 with Black Integrated handle 26070-01-S |
| Overlay | U-2275DWRCOL-00 |

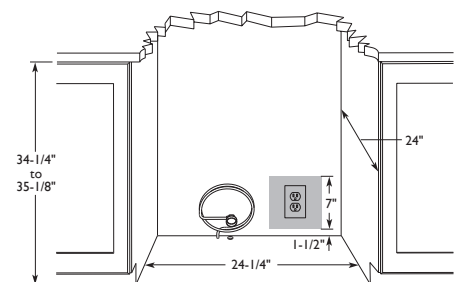

Please visit www.u-line.com for installation guide.

All specifications are subject to change without notice.

