



Stainless

Overlay

## 2175RCG

2000 SERIES

### FEATURES

#### PERFORMANCE

- 5.4 cubic feet overall capacity maximizes storage
- Touch glass digital control featuring easy view command center manages key functions and provides user alerts such as an audible door open alarm
- Digital controlled single-zone convection cooling system provides a stable and consistent environment for optimum food and beverage storage
- Temperature setting from 34 to 45° F
- Sabbath / Blackout mode turns off all lighting, controls display and automatically resets after 36 hours
- Automatic defrost
- ENERGY STAR® / CEE Tier 1 rated
- UL residential and commercial listings

#### INTERIOR / EXTERIOR

- Dual lighted black interior optimizes elegant and easy viewing of contents
- Three 6mm tempered glass shelves with bullnose edge to maximize storage potential
- Convenient crisper drawer for proper storage and humidity control of perishable items
- Standard commercial stainless steel handle is interchangeable with professional handle option on stainless steel model
- Full wrap stainless door on stainless model and unit must be ordered right or left hand hinged
- Overlay model door is field reversible and comes ready for overlay application
- LowE coated, argon gas filled thermopane glass door provides protection from harmful UV rays and added insulating energy efficiency
- Black vinyl clad textured cabinet is more resistant to scratching, peeling and flaking

#### INTEGRATION

- Unit can be built-in or freestanding providing a custom aesthetic
- Overlay model accepts a full 3/4" overlay frame and can be fully integrated into all styles of cabinetry
- Allow a 2-1/2" clearance on hinged side for 90° door opening when installed adjacent to a wall (for stainless steel model)
- Allow 1/4" width overall for proper installation (see backside for details)
- No additional clearance around sides, top or rear of unit is needed for ventilation
- Durable, factory installed level legs provide a more precise undercounter fit
- Do not obstruct front grille air flow

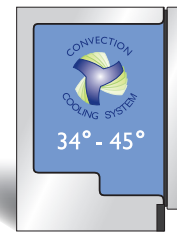

Single Zone  
Convection Cooling  
System featured in  
2175RCG.



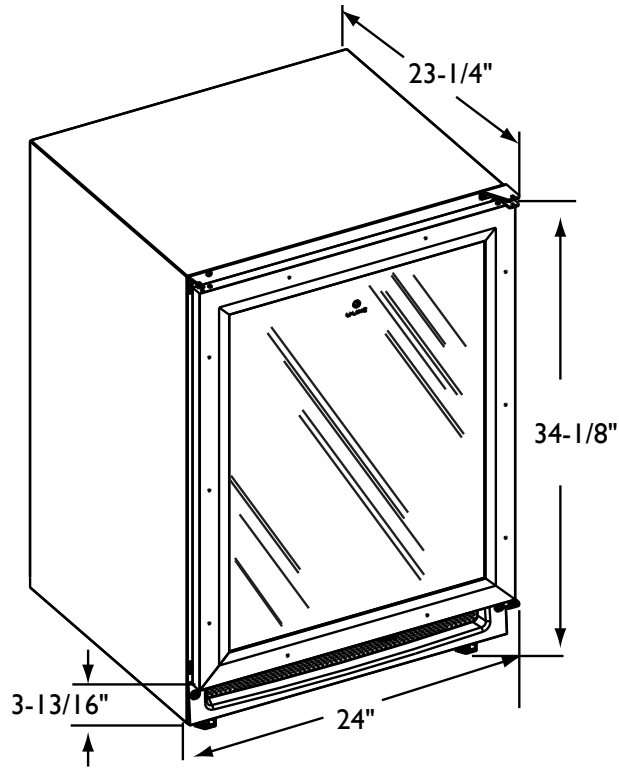

2175RCG Stainless Model

## DIMENSIONS AND SPECIFICATIONS

## OVERALL DIMENSIONS

Height	34-1/8" (86.6)
Width	24" (60.8)
Depth	23-1/4" (59.0)
With stainless steel handle	25-1/8" (63.8)

## Shipping weight:

Overlay model	122 lbs (55 kg)
Stainless model	1116 lbs (53 kg)

Running amps	2.4
Maximum start-up amps	9.8
Amps pertain to voltage rating	110/115 volt, 60 Hz
ENERGY STAR® and CEE Tier I	

## Capacities:

Defrost technology	Automatic
Refrigerator volume	5.4 Cu. Ft

## 2175RCG

Stainless Right-hand	U-2175RCGS-00
Stainless Left-hand	U-2175RCGS-01
Overlay	U-2175RCGOL-00

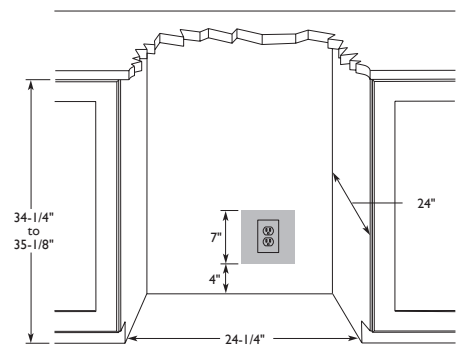

Please visit [www.u-line.com](http://www.u-line.com) for installation guide.

All specifications are subject to change without notice.

