



Stainless

Black

ADA24R

ADA SERIES

FEATURES

PERFORMANCE

- 5.3 cubic feet overall capacity allows for storage of more than 7-1/2 cases of 12 oz beverages
- Touch pad digital control featuring easy view command center manages key functions and provides user alerts such as a door open alert
- Digital controlled single-zone convection cooling system provides a stable and consistent environment for optimum food and beverage storage
- Temperature setting from 34 to 45° F
- Sabbath / Blackout mode turns off all lighting, controls display and automatically resets after 36 hours
- Automatic defrost
- ENERGY STAR® / CEE Tier 3 rated
- UL residential and commercial listings

INTERIOR / EXTERIOR

- 28-1/2" height meets ADA height requirement yet maximizes allowable space
- Four heavy duty chrome wire shelves
- Standard commercial stainless steel handle is interchangeable with professional handle option for stainless steel model
- Stainless steel wrap door with black end caps on stainless model must be ordered left or right hand hinged
- Solid black door is field reversible
- Black vinyl clad textured cabinet is more resistant to scratching, peeling and flaking
- Door lock standard on all models

INTEGRATION

- Unit can be built-in or freestanding providing a custom aesthetic
- Allow a 2-1/2" clearance on hinged side for 90° door opening when installed adjacent to a wall (for stainless steel model)
- Black model will accept a 1/4" insert panel to match with surrounding decor
- Allow 1/4" width overall for proper installation (see backside for details)
- No additional clearance around sides, top or rear of unit is needed for ventilation
- Durable, factory installed level legs provide a more precise undercounter fit
- Do not obstruct front grille air flow

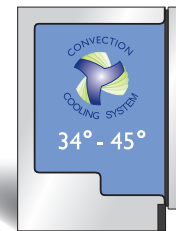

Single Zone
Convection Cooling
System featured in
ADA24R.



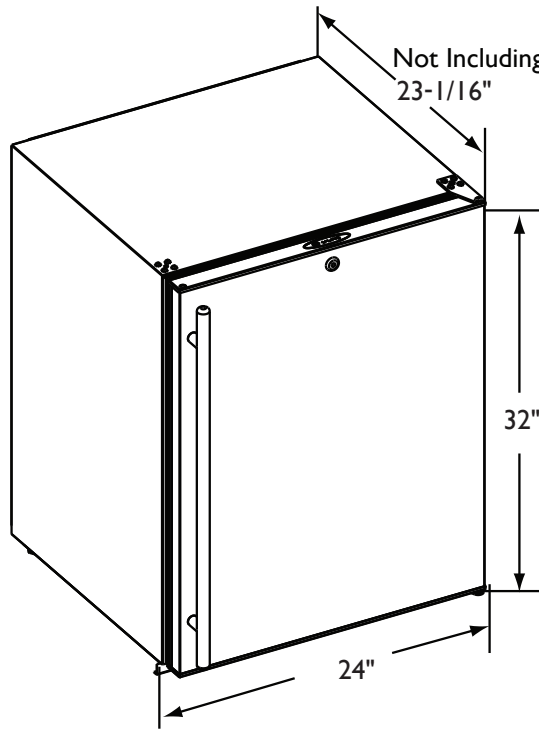

ADA24RS Stainless Model

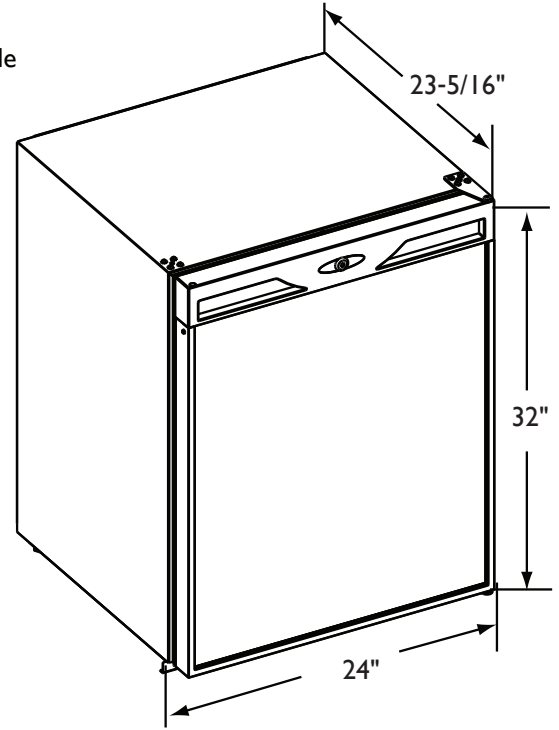

ADA24RB Black Model

DIMENSIONS AND SPECIFICATIONS

OVERALL DIMENSIONS

Height	32" (81.3)
Width	24" (60.9)
Depth	23-1/4" (59.0)
With stainless steel handle	24-15/16" (63.3)

Shipping weight:

Solid Door Model 114 lbs (52 kg)

Running amps	2.4
Maximum start-up amps	9.8
Amps pertain to voltage rating	110/115 volt, 60 Hz
ENERGY STAR® and CEE Tier 3	

Capacities:

Defrost technology	Automatic
Refrigerator volume	5.3 Cu. Ft
Holds more than 7-1/2 cases of 12 oz canned beverages	

ADA24R

Stainless Right-hand	U-ADA24RS-I3
Stainless Left-hand	U-ADA24RS-I5
Black	U-ADA24RB-I3

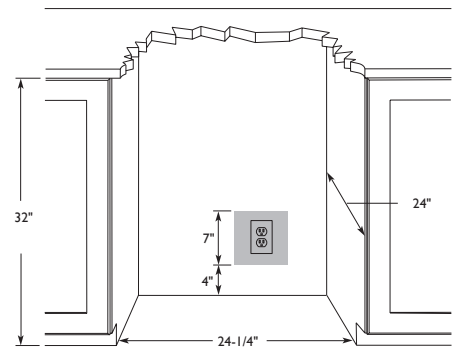

Please visit www.u-line.com for installation guide.

All specifications are subject to change without notice.

