

# Cingoli



## ISLAND CHIMNEY HOOD

Designed to be suspended above a kitchen island, Cingoli takes flight with graceful 36" or 42" arched glass wings, which allow natural light to illuminate the surface below. The expansive glass wings are complemented by reflective stainless steel. The beauty of Cingoli is combined with features like a powerful 600 CFM blower, dishwasher-safe anodized aluminum mesh filters and high-tech multi-function LCD controls that deliver convenience and safety. Designed for standard ducted installation, Cingoli can also be installed as a recirculating system using the Recirculating Kit, available as an accessory.

## FEATURES

### • **Advanced Electronic Touch Controls**

State-of-the-art electronics deliver maximum user convenience and control. LCD function display with elegant blue illumination combined with low-profile, easy-to-clean touchpads is your interface with a multi-function control system, including...

- On/Off control
- Programmable timer and buzzer
- Four blower speeds
- Clock
- **HeatGuard™** automatically adjusts blower speed if heat exceeds 158°F for safety and convenience
- Two light intensities
- Filter Saturation Monitor detects excessive levels within both grease and charcoal filters



### • **600 CFM 4-Speed Internal Blower**

- **4 Halogen Lamps** with two light intensities (12V 20W bulbs included)
- **Dishwasher-Safe Anodized Aluminum Mesh Filters** (2 with 36" unit, 3 with 42" unit)



### **Stainless Steel Mesh Filter**

Available as an optional upgrade  
*(see back for accessory details)*

- **Telescopic Chimney Extension** – For ceiling heights 7' 10" to 10'
- **8" Round Duct Transition**
- **One-Way No Return Valve** eliminates outside air drafts.

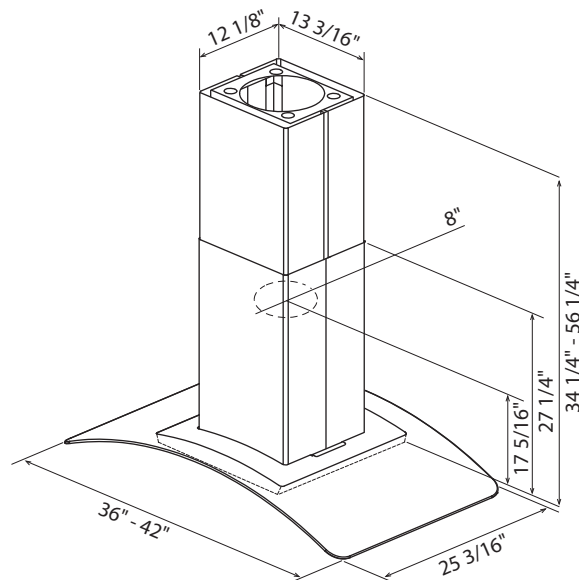

MODEL NUMBER	FINISH	DIMENSIONS WIDTH	DEPTH	SHIPPING WEIGHT
ECN636SS	Stainless Steel & Glass	36"	25-3/16"	102 lbs
ECN642SS	Stainless Steel & Glass	42"	25-3/16"	109 lbs

**HOOD MOUNTING HEIGHT ABOVE COOKING SURFACE**

GAS		ELECTRIC	
minimum	maximum	minimum	maximum
30"	34"	24"	30"

**CHIMNEY HEIGHT** (based on recommended mounting heights listed above)

DUCTED		RECIRCULATING	
Gas min./max.	Electric min./max.	Gas min./max.	Electric min./max.
8' 4" - 10'	7' 10" - 9' 8"	8' 4" - 10' 6"	7' 10" - 10' 2"

**BLOWER PERFORMANCE**

SPEED LEVEL	AIRFLOW IN CFM (CUBIC FEET PER MINUTE)	SOUND LEVEL (IN SONES)
1	160	1.6
2	280	3.5
3	470	6.5
4	600	8.7

**CINGOLI ACCESSORIES**

MODEL NUMBER	DESCRIPTION	SHIPPING WEIGHT
EXXRCK04	Recirculating Kit	8.8 lbs
EXXRCK02	CFM Reduction Kit	5.5 lbs
EXXGFKSS	Stainless Steel Mesh Filter	5.5 lbs

  **ELECTRICAL:**  
AC Input: 120V - 60Hz, AC Power Max.: 530W at 4.4 Amps