

# Lugano



## WALL-MOUNT CHIMNEY HOOD

With Lugano, the beauty of stainless steel conveys understated elegance, with a gently tapered hood that measures only 5" high. Available in 30" or 36" width, Lugano features include a powerful 600 CFM blower, halogen lighting with 2 light intensities, dishwasher-safe anodized aluminum mesh filters and high-tech multi-function LCD controls that deliver convenience and safety. Designed for standard ducted installation, Lugano can also be installed as a recirculating system using the Recirculating Kit, available as an accessory.

## FEATURES

### • **Advanced Electronic Touch Controls**

State-of-the-art electronics deliver maximum user convenience and control. LCD function display with elegant blue illumination combined with low-profile, easy-to-clean touchpads is your interface with a multi-function control system, including...

- On/Off control
- Programmable timer and buzzer
- Four blower speeds
- Clock
- **HeatGuard™** automatically adjusts blower speed if heat exceeds 158°F for safety and convenience
- Two light intensities
- Filter Saturation Monitor detects excessive levels within both grease and charcoal filters



### • **600 CFM 4-Speed Internal Blower**

### • **2 Halogen Lamps** with two light intensities (120V 50W bulbs included)

### • **Dishwasher-Safe Anodized Aluminum Mesh Filters** (2 with 30" unit, 3 with 36" unit)



### **Elica-Patented Stainless Steel Micro Hole Filter**

Available as an optional upgrade  
(see back for accessory details)

- **Telescopic Chimney Extension** – For ceiling heights 7' 1" to 9' 1"
- **8" Round Duct Transition**
- **One-Way No Return Valve** eliminates outside air drafts.

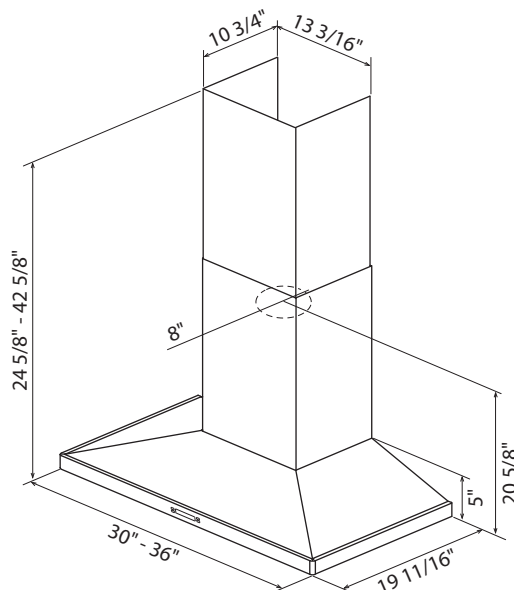

<b>MODEL NUMBER</b>	<b>FINISH</b>	<b>WIDTH</b>	<b>DIMENSIONS DEPTH</b>	<b>HEIGHT</b>	<b>SHIPPING WEIGHT</b>
ELG630SS	Stainless Steel	30"	19-11/16"	5"	54 lbs
ELG636SS	Stainless Steel	36"	19-11/16"	5"	59 lbs

**HOOD MOUNTING HEIGHT ABOVE COOKING SURFACE**

<b>GAS</b>		<b>ELECTRIC</b>	
minimum	maximum	minimum	maximum
30"	34"	24"	30"

**CHIMNEY HEIGHT** (based on recommended mounting heights listed above)

<b>DUCTED</b>		<b>RECIRCULATING</b>	
Gas min./max.	Electric min./max.	Gas min./max.	Electric min./max.
7' 7" - 9' 1"	7' 1" - 8' 9"	7' 11" - 9' 4"	7' 5" - 9'

**BLOWER PERFORMANCE**

<b>SPEED LEVEL</b>	<b>AIRFLOW IN CFM</b> (CUBIC FEET PER MINUTE)	<b>SOUND LEVEL</b> (IN SONES)
1	160	1.4
2	280	3.2
3	475	6.0
4	600	8.2

**LUGANO ACCESSORIES**

<b>MODEL NUMBER</b>	<b>DESCRIPTION</b>	<b>SHIPPING WEIGHT</b>
EXXRCK05	Recirculating Kit	6.6 lbs
EXXRCK02	CFM Reduction Kit	5.5 lbs
EXXGFKMH	Stainless Steel Micro Hole Filter	5.5 lbs



**ELECTRICAL:**

AC Input: 120V - 60Hz, AC Power Max.: 550W at 4.6 Amps