

# SCOTSMAN

WATER FILTRATION SYSTEMS AND REPLACEMENT CARTRIDGES



## SSM - A WATER FILTERS

### CLEANER, MORE CONSISTENT ICE CUBES

- Drastically reduces unscheduled, water-related maintenance calls...by as much as 40%.
- Reduces the formation of lime scale, the number one cause of service related problems.
- 99% removal of corrosive chlorine from the incoming water supply.
- Takes out off-tastes and odors.
- Traps dirt and rust particles as small as one-half micron in size, resulting in crystal clear, healthier ice.

### WARRANTY *See dealer for complete warranty details.*

- 5 year parts only

### NSF INTERNATIONAL STANDARDS

#### Standard No. 42: Aesthetic Effects

##### Chemical Unit

Chlorine Reduction, Class I

Taste and Odor and Reduction

##### Mechanical Filtration Unit

Particulate Reduction, Class I:

99.9% reduction of particles

1/2 micron and larger in size

#### Standard No. 53: Health Effects

##### Mechanical Filtration Unit

Turbidity Reduction

Cyst Reduction

Asbestos Reduction

The SSM filter and replacement cartridge have been Tested and Listed by NSF only for the functions listed above. Check for compliance with state and local laws and regulations. Do not use where the water is microbiologically unsafe, or with water of unknown quality without adequate disinfection before or after the unit. Can be used on water that may contain filterable cysts.

CERTIFIED  
**ISO**  
9001:2000

This product qualifies for the following listings:



Tested and Certified to  
ANSI/NSF Standards 42 & 53

 **Scotsman**<sup>®</sup>

# Water Filtration Systems & Replacement Cartridges

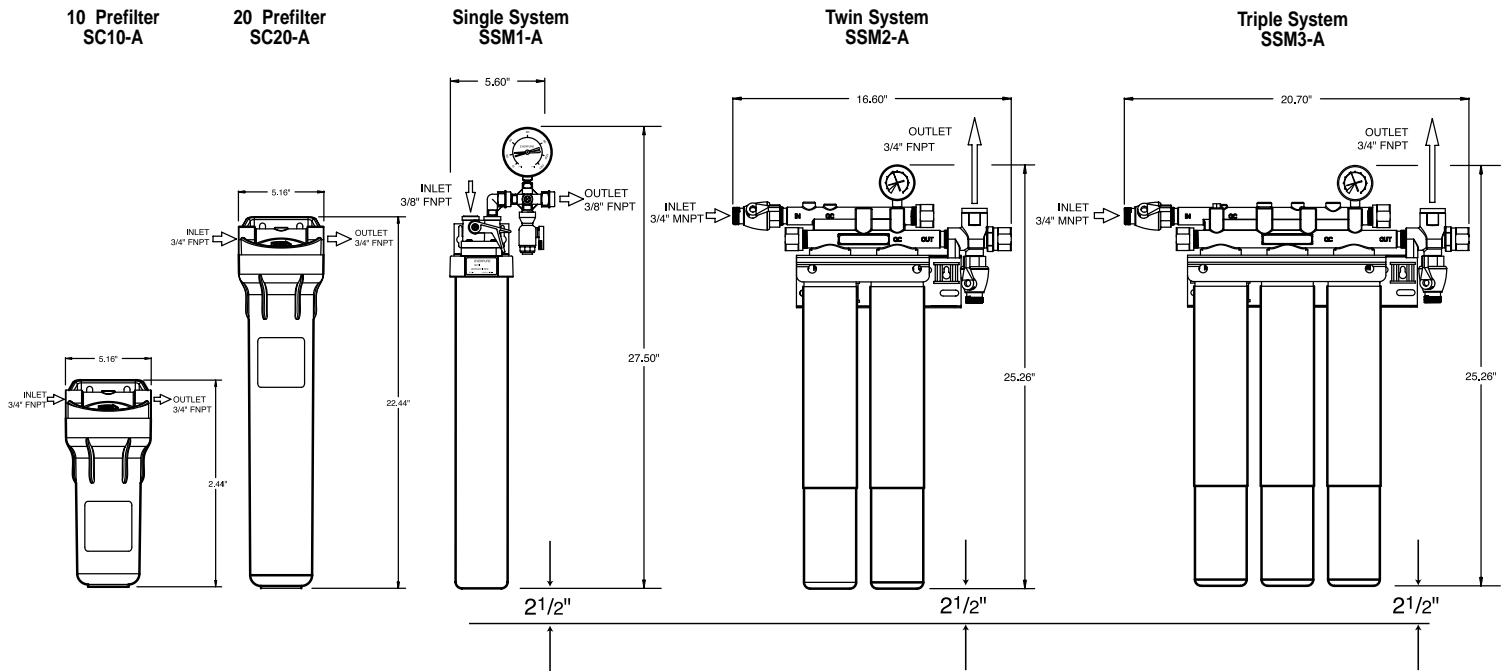

**IMPORTANT:** Must have minimum 2 1/2" clearance for cartridge change.

## Water Filter Systems

Model	Dimensions* W x D x H	Shipping Weight lb./kg.	Used On	Flow Rate gallons per minute
SSM1-A	69 x 59 x 29 1/2"	7/3	Cubers up to 650 lb., flakers, nuggets, and nugget dispensers up to 1,200 lb.	1.67
SSM2-A	12" x 5 1/2" x 25 1/2"	11/5	Cubers from 650 to 1300 lbs., flakers and nuggets over 1,200 lb.	3-34
SSM3-A	15 1/2" x 5 1/2" x 25 1/2"	16/7	Cubers over 1300 lbs.	5.01

## Coarse Pre-Filters

SC10-A	7" x 7" x 14"	5/2	10" Coarse prefilter to remove particles	5.00
SC20-A	7" x 7" x 24 1/8"	11/5	20" Coarse prefilter to remove particles	10.00

\*Includes 2 1/2" clearance below.

## REPLACEMENT CARTRIDGES

Model	Per Package Quantity	Shipping Weight lb./kg.	Used On
SSMRC1	1	3/1	SSM1-A - SSM3-A
SSMRC6	6	7/3	SSM2-A - SSM3-A
SC10RC40	40	17/8	SC10-A
SC20RC20	20	17/8	SC20-A

## IMPORTANT OPERATING REQUIREMENTS:

	Minimum	Maximum
Air Temperatures	50°F (10°C)	100°F (37.7°C)
Water Temperatures	40°F (4.4°C)	100°F (37.7°C)
Water Pressures	20 PSIG	80 PSIG
Capacity	Certified for chlorine reduction for up to 9000 gallons	
Flow Rate	1.67gpm (6.3 Lpm) per cartridge	

Scotsman's ice machines are not designed for outdoor installations. Scotsman remote condensers are designed for outdoor installations.

Machine requires voltage indicated on rating name plate. Failures caused by improper voltage are not considered factory defects. Extended periods of operation at temperatures exceeding limitations constitutes misuse under the terms of Scotsman Manufacturer's Limited Warranty, resulting in a loss of warranty coverage. Specifications and design are subject to change without notice.

**Consult Your Local SCOTSMAN Representative At:**

**YOU'LL VALUE THE DIFFERENCE.™**

775 Corporate Woods Parkway • Vernon Hills, IL 60061 • 1-800-SCOTSMAN • Fax: (847) 913-9844  
Visit our website at: [www.scotsman-ice.com](http://www.scotsman-ice.com) • E-mail: [customer.service@scotsman-ice.com](mailto:customer.service@scotsman-ice.com)

 **Scotsman**®