

FS20LGL7VK

20.75" x 19.75" x 21.0" (H x W x D)

Commercially approved glass door vodka freezer in compact size

Highlights:

Glass door highlights collection

Factory-installed lock provides security you can depend on

Compact size for a convenient fit

Commercially approved for use in foodservice establishments



Commercially approved	ETL-S Approved to ANSI-NSF Standard 7 and CalCode Compliant
Compact dimensions	Square footprint for placement on top of counters
Glass door	Display your collection with unique style
Ceiling racks	Hang martini glasses for a luxurious look
Front-mounted lock	Keep contents secure with a key lock on the door
Reversible door	Keep your options flexible with a reversible door that is easy to switch when your arrangement changes
Manual defrost operation	No temperature fluctuations with a static manual defrost system that keeps the cold inside
Fluorescent light	Switch on the interior light to illuminate your collection
100% CFC free	Environmentally friendly design without ozone-damaging chemicals
Fully finished white cabinet	Allows the unit to be used freestanding

Specifications:

Height	20.75"
Width	19.75"
Depth	21.0"
Capacity	1.6 cu.ft.
Interior Height 1	14.5"
Interior Width 1	15.5"
Interior Depth 1	15.0"
Comp Step Height	8.5"
Comp Step Width	15.5"
Comp Step Depth	7.0"
Shipping Weight	68.0 lbs.
Amps	1.43
US Electrical Safety	UL
Energy Usage/Year	277.0 kWh/year
Canadian Electrical Safety	ULC
Shelf Quantity	1
Adjustable Shelf	true
Depth with door at 90°	38.0"
Height to Hinge Cap	20.0"
Defrost Type	Manual
Light	true
Condensor Location	Rear of Unit
Thermostat Type	Dial
Low Side PSI	88.0
Level Legs Quantity	2
High Side PSI	250.0
Freon Type	R134a
Freon Oz	3.17
Compressor Warranty	5 Years
Parts/Labor Warranty	1 Year
Sanitation	NSF

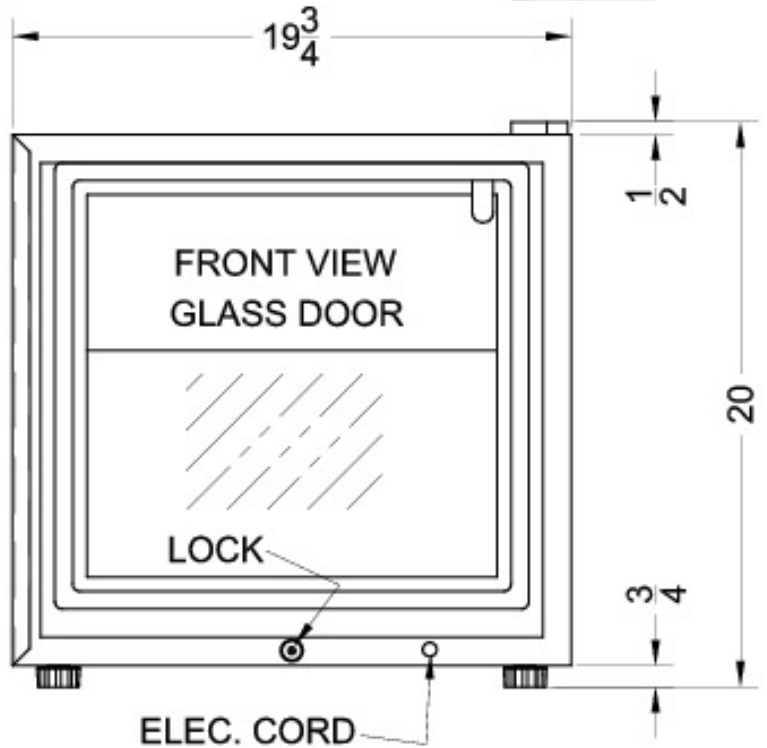
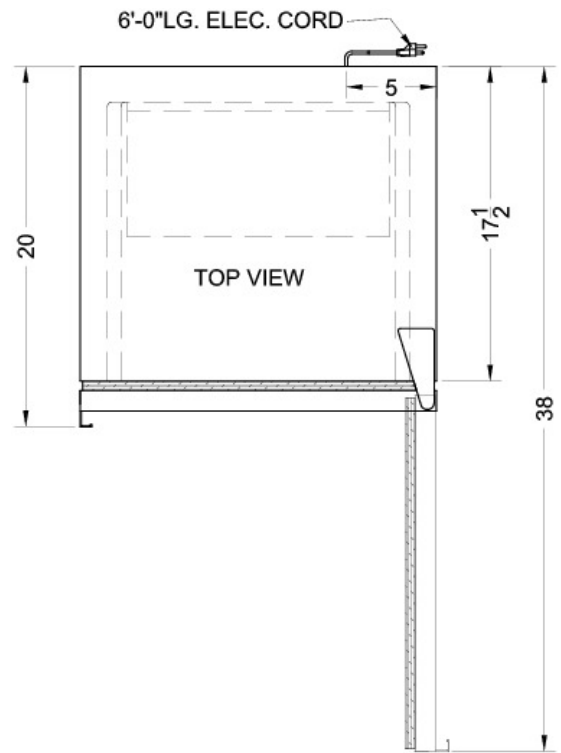

Summit Appliances Division, Felix Storch, Inc.
 770 Garrison Ave • Bronx, NY 10474
 Phone: 718-893-3900 • Fax: 718-842-3093
 Email: info@summitappliance.com