

**CP35B**

33.5" x 18.75" x 20.25" (H x W x D)

Compact ENERGY STAR listed two-door refrigerator-freezer with cycle defrost and zero degree freezer in black

**Highlights:**

Extremely narrow 19" width fits into even the tightest spaces

Ice cream stays frozen in zero degree freezer

ENERGY STAR qualified for guaranteed savings

Cycle defrost system saves energy while protecting food



ENERGY STAR qualified	Rated by the DOE to perform with more efficiency than federal standards require, saving your unit energy and you on higher utility costs
Thin-line design	Limited space is no problem for our thin-line models, designed specifically for those hard-to-fit spots
Dual evaporator cooling	SUMMIT's unique and efficient dual evaporator separately cools the refrigerator while maintaining zero degrees in the freezer
Cycle defrost	Combines an automatic defrosting refrigerator with a manual defrosting freezer to save energy
Reversible doors	Keep your options flexible with reversible doors that are easy to switch when your arrangement changes
Interior light	Automatically illuminates when you open the door
Door storage	Store large bottles right on the door for easy access
Two-door design	One of the few two-door refrigerator-freezer units of its size in the industry
Adjustable shelves	Rearrange your refrigerator space to accommodate all shapes and sizes or remove shelves for a simple clean-up
Adjustable thermostat	Control your food's temperature with ease and accuracy

## Specifications:

Height	33.5"
Width	18.75"
Depth	20.25"
Capacity	2.9 cu.ft.
Interior Height 1	19.0"
Interior Width 1	16.0"
Interior Depth 1	14.0"
Interior Height 2	6.0"
Interior Width 2	14.0"
Interior Depth 2	10.5"
Comp Step Height	8.0"
Comp Step Width	19.0"
Comp Step Depth	4.0"
Shipping Weight	102.0 lbs.
Canadian Electrical Safety	ULC
US Electrical Safety	UL
Energy Usage/Year	290.0 kWh/year
Amps	1.4
Voltage/Frequency	115 V AC/60 Hz
Other Energy Info	120 Volts / 60 Hz.
Crisper Quantity	1
Shelf Quantity	1
Adjustable Shelf	true
Shelf Type	Glass
Crisper Cover Type	Glass
Crisper Finish	Transparent
Full Door Shelf Quantity	2
Depth with door at 90°	37.25"
Height to Hinge Cap	33.5"
Defrost Type	Cycle
Thermostat Type	Dial
Light	true
Condensor Location	Rear of Unit
Freon Type	R134a
High Side PSI	235.0
Low Side PSI	140.0
Level Legs Quantity	2
Freon Oz	2.6
Compressor Warranty	5 Years
Parts/Labor Warranty	1 Year

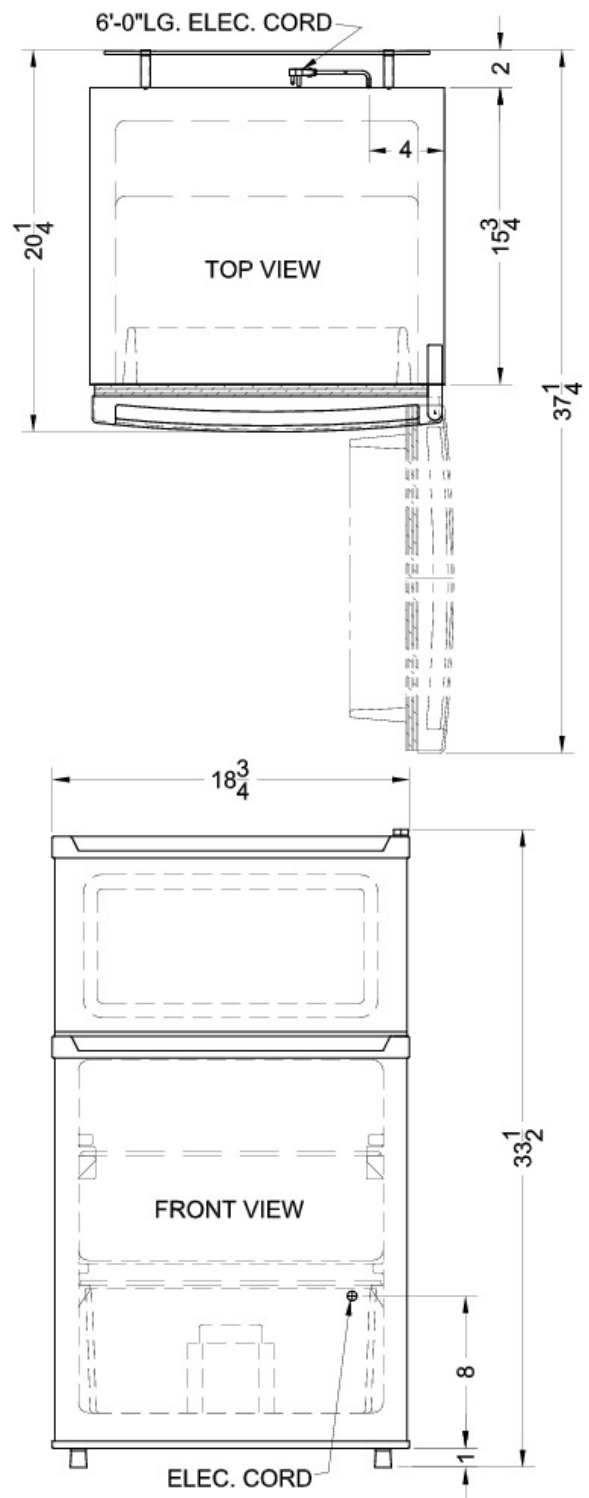

Summit Appliances Division, Felix Storch, Inc.  
 770 Garrison Ave • Bronx, NY 10474  
 Phone: 718-893-3900 • Fax: 718-842-3093  
 Email: info@summitappliance.com