



OUTDOOR—REFRIGERATION

Undercounter/Freestanding 15"W. Ice Machine



Standard Features & Accessories

Model includes

- Bin capacity—35 lbs.
- Agency-certified for outdoor use
 - Insulated electrical terminals, sealed electrical contacts, and water-resistant thermostat
 - Permanently lubricated sealed compressor and pump ensure long life and professional performance
- Heavy-duty commercial-type construction, design, and styling
 - Stainless steel exterior cabinet surrounds unit and forms a water-resistant seal
 - Stainless steel kickplate
 - Stainless steel-covered ice bin front
- 3/4" square, clear ice
- Produces up to 35 lbs. of ice per day
- Operating range between 45° and 110° F (7.2° and 43° C)
- Heavy-duty ice scoop included
- Stainless steel ice cutter
- Draining process automatically removes old ice to ensure a constant supply of fresh ice
- Equipped with cleaning mode
- Adjustable leveling legs
- Install as undercounter or freestanding unit
- Can be installed in existing cutouts with little or no cabinetry alterations
- Must be ordered right or left hinge (As you face unit, RIGHT has hinge on right side and handle on left side; LEFT has hinge on left side and handle on right side)

Model Options



VUIM153T
Outdoor Ice Machine

FINISH DETAILS

- Stainless Steel (SS)

ORDERING INSTRUCTIONS

First specify model number, followed by hinge preference ("R" for right or "L" for left)—(VUIM153TRSS).





OUTDOOR—REFRIGERATION

Undercounter/Freestanding 15"W. Ice Machine



★ Please see **Installation Notes & Accessories** for important information, including drain pump.

Dimensions & Specifications

PRODUCT DIMENSIONS & DOOR SWING



VUIM153T

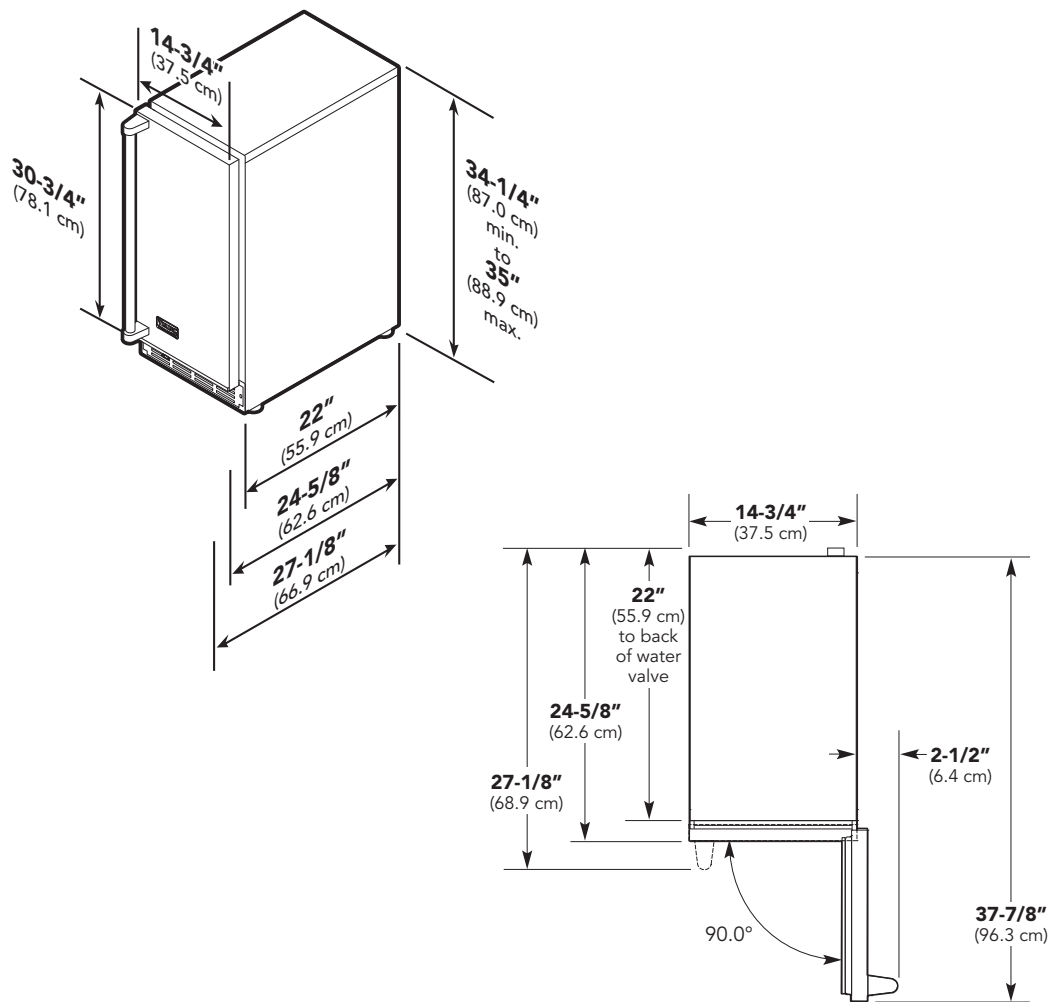

VUIM153T

Overall width	14-3/4" (37.5 cm)
Overall height (from bottom) (leveling legs fully extended)	34-1/4" (87.0 cm) min. to 35" (88.9 cm) max.
Overall depth (from rear)	
To front of handle	27-1/8" (68.9 cm)
With door fully open	37-7/8" (96.3 cm)
Approx. ship weight	110 lbs. (49.5 kg)





OUTDOOR—REFRIGERATION

Undercounter/Freestanding 15"W. Ice Machine



UTILITY REQUIREMENTS



GAS
Not applicable



- ELECTRICAL**
- 7' (2.1 m), 3-wire cord with grounded, 3-prong plug attached to product
 - 115 VAC/60 Hz; 15-amp dedicated circuit
 - Max. amp usage—3.0



- PLUMBING**
- Inlet waterline requirements—1/4" (0.64 cm) copper tubing
 - 20 psi min.; 120 psi max.

Installation Requirements

ACCESS REQUIREMENTS



VUIM153T

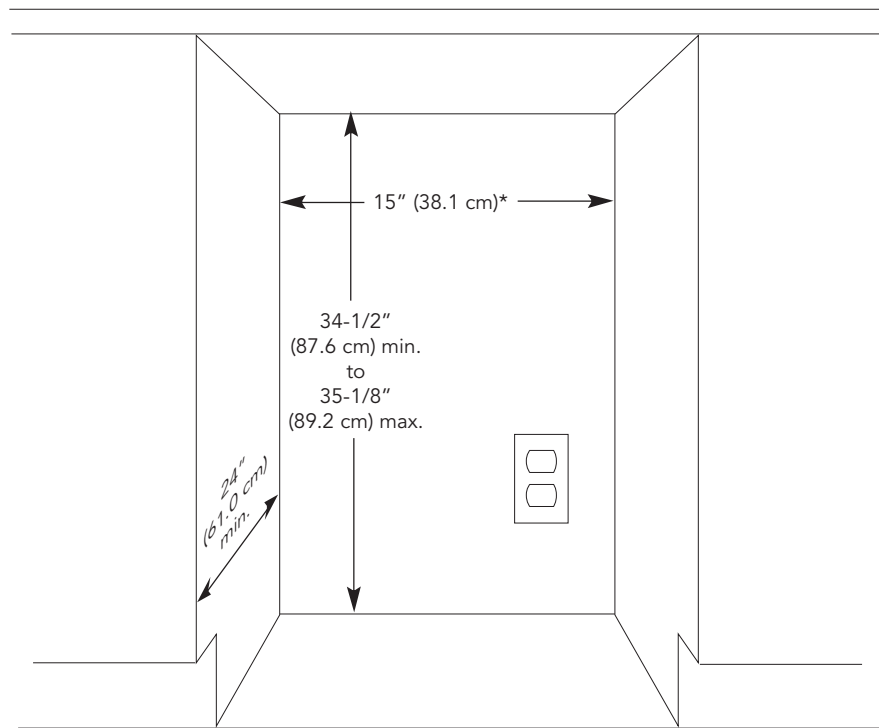

*15" (38.1 cm) width for cabinet only; If door is recessed between cabinets, cutout must be 15-1/4" (38.7 cm).

VUIM153T

Cutout width	15" (38.1 cm)*
Cutout height	34-1/2" (87.6 cm) min. to 35-1/8" (89.2 cm) max.
Cutout depth	24" (61.0 cm)





OUTDOOR—REFRIGERATION

Undercounter/Freestanding 15"W. Ice Machine



✦ Installation Notes & Accessories

Sealed Reservoir Drain Pump Kit

- Exclusively for ice machines
- For use when floor drain is not available
- Completely sealed reservoir
- Unit shuts off power to ice machine in the event of a pump failure
- Special design makes the possibility of foreign material clogging pump very remote
- Check valve in discharge tube prevents discharge water from flowing back into the pump
- Supplied with 2-wire with ground/3-prong plug for connection to 115VAC/60Hz and incorporates a power receptacle into which the the ice machine is plugged
- Kit includes one pump and other parts/hardware

Model	Description	Approx. ship wt. lbs. (kg)
DP-VUIM	Sealed reservoir drain pump	2 (0.9)

Stainless Steel Cabinetry-Bases

- Stainless Steel (SS)
- For use with 15"W. & 24"W. Viking outdoor refrigeration products
- See individual product pages (storage section) for more information and additional specifications

Model	Description	Approx. ship wt. lbs. (kg)
VURO2400	Base for 15"W outdoor refrigerator	115 (52.2)

Compliance Information



WARRANTY SUMMARY*

- Two-year full warranty—complete unit (w/in-home repairs)
- Six-year full warranty—sealed refrigeration system (includes compressor, condenser, dryer/strainer, evaporator, and connecting tubing)
- Twelve-year limited warranty—sealed refrigeration system
- Ninety-day limited warranty—cosmetic parts such as glass, painted, and decorative items

*For complete warranty see *Use & Care Guide*. Warranty valid on Viking products shipped within the United States and Canada.

