

MRF35B

45.0" x 18.75" x 22.0" (H x W x D)

Refrigerator-freezer-microwave combination unit with cycle defrost and black finish

Highlights:

Combination refrigerator-freezer-microwave serves all your kitchen needs in a slim 19 inch wide fit

Energy efficient refrigerator-freezer for convenience and utility savings

Ships fully assembled

Electrical allocator box protects unit from circuit breaks by limiting power usage to 10 amps



| | |
|----------------------------|---|
| Thin-line design | Limited space is no problem for our thin-line models, designed specifically for those hard-to-fit spots |
| CP35B Refrigerator-freezer | Two-door ENERGY STAR qualified compact with cycle defrost and deluxe interior that includes adjustable shelves, door racks, and crisper |
| SM902B microwave oven | Touchpad mid-sized microwave with one-touch cook options and variable controls |
| Allocator box | Plug the refrigerator-freezer, microwave, and a third appliance into this allocator box for safe operation that limits total power consumption to 10 amps |
| Ships fully assembled | No assembly required before use |
| Reversible doors | Keep your options flexible with reversible refrigerator and freezer doors that are easy to switch when your arrangement changes |
| Black exterior | Jet black finish on both refrigerator-freezer and microwave |

Specifications:

| | |
|----------------------------|------------|
| Height | 45.0" |
| Width | 18.75" |
| Depth | 22.0" |
| Shipping Weight | 145.0 lbs. |
| US Electrical Safety | UL |
| Canadian Electrical Safety | ULC |
| Defrost Type | Cycle |
| Parts/Labor Warranty | 1 Year |

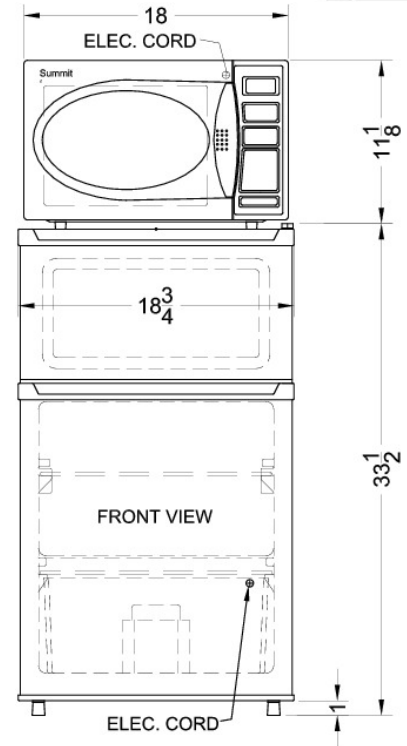
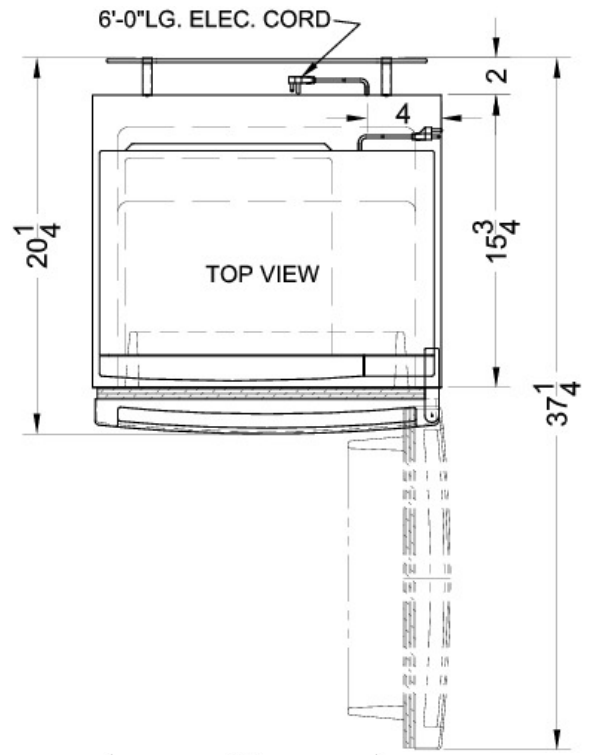

Summit Appliances Division, Felix Storch, Inc.
770 Garrison Ave • Bronx, NY 10474
Phone: 718-893-3900 • Fax: 718-842-3093
Email: info@summitappliance.com