



## ADA-compliant Series

### 24" One Door Cabinet Specification Sheet



Freezer



Refrigerator



Beverage Center



Wine Reserve



Ice Maker

#### Features

- 32" height with leveling legs
- Designed for maximum capacity while adhering to strict 34-inch counterheight ADA-compliant requirements
- Fully-integrated depth to allow flush fit with surrounding cabinetry
- Zero-clearance hinging allows for abutment with surrounding cabinetry
- With 3/4-inch wood overlay, the unit will stand flush with cabinetry
- Best in Class 700 Btu commercial-grade compressor
- Front-vented, RAPIDcool forced-air refrigeration system
- Commercial-grade stainless steel interior
- Maintenance-free automatic cycle free defrost
- *Industry Exclusive* convertible door design allows all doors the ability to be converted to wood overlay from stainless steel
- Low E, UV coated glass provides industry leading insulation and protection

#### Freezer features:

- Available with solid stainless steel door, solid wood overlay door, stainless steel drawers or wood overlay drawers
- Full-extension shelves/drawers pull completely out of the unit allowing easy storage and access to freezer contents
- Equipped with automatic hot gas defrost for maintenance-free defrosting
- Freezer temperature -10 – 10 degrees F

#### Refrigerator features:

- Available with solid stainless steel door, solid wood overlay door, glass with stainless trim door, glass with wood trim door, stainless steel drawers or wood overlay drawers
- *Industry Exclusive* full-extension pull-out shelves makes finding items and restocking your refrigerator easy
- Full-extension shelves are adjustable
- Stainless steel ball bearing glides provide smooth movement of shelves
- *Industry Exclusive* drawers
- Refrigerator rated for both food and beverage storage
- Refrigerator temperature 33 – 39 degrees F

#### Beverage Center features:

- Available with glass with stainless trim door or glass with wood trim door
- Allows for storage of both wine and beverages
- Two (2) wine shelves, one (1) *Industry Exclusive* full-extension pullout shelf
- Shelving positions are adjustable to suit your needs
- Beverage Center temperature 36 – 48 degrees F

#### Wine Reserve features:

- Available with glass with stainless trim door or glass with wood trim door
- Five (5) shelves will store 40 wine bottles with extra storage under shelves for up to five (5) additional bottles
- Shelving positions are adjustable to suit your needs
- Wine Reserve temperature 40 – 60 degrees F

#### Ice Maker features:

- Produces up to 55 pounds of ice per day and stores up to 27 pounds of ice
- UL-approved for outdoor use
- Quiet, efficient operation
- Optional drain pump
- Elegant stainless steel door and polished handle

*Luxury* YOU DESIRE.  
INNOVATION YOU CAN'T LIVE WITHOUT.



8300 W. Good Hope Rd. • Milwaukee, WI 53223  
1-800-558-5592 • Fax: (414) 353-7069 • www.Perlick.com

Perlick is committed to continuous improvement. Therefore, we reserve the right to change specifications without warning

24 ADA-Compliant Series	
Build In Models	Freezers
HA24FB-1L	24" Built-in ADA Compliant freezer with solid stainless steel door hinge left
HA24FB-1R	24" Built-in ADA Compliant freezer with solid stainless steel door hinge right
HA24FB-2L	24" Built-in ADA Compliant freezer with integrated wood overlay solid door hinge left
HA24FB-2R	24" Built-in ADA Compliant freezer with integrated wood overlay solid door hinge right
HA24FB-5	24" Built-in ADA Compliant freezer with solid stainless steel drawers
HA24FB-6	24" Built-in ADA Compliant freezer with integrated wood overlay drawers
Refrigerators	
HA24RB-1L	24" Built-in ADA Compliant refrigerator with sold stainless steel door hinge left
HA24RB-1R	24" Built-in ADA Compliant refrigerator with sold stainless steel door hinge right
HA24RB-2L	24" Built-in ADA Compliant refrigerator with integrated solid wood overlay door hinge left
HA24RB-2R	24" Built-in ADA Compliant refrigerator with integrated solid wood overlay door hinge right
HA24RB-3L	24" Built-in ADA Compliant refrigerator with stainless steel glass door hinge left
HA24RB-3R	24" Built-in ADA Compliant refrigerator with stainless steel glass door hinge right
HA24RB-4L	24" Built-in ADA Compliant refrigerator with integrated wood overlay glass door hinge left
HA24RB-4R	24" Built-in ADA Compliant refrigerator with integrated wood overlay glass door hinge right
HA24RB-5	24" Built-in ADA Compliant refrigerator with solid stainless steel drawers
HA24RB-6	24" Built-in ADA Compliant refrigerator with integrated wood overlay drawers
Wine Reserves	
HA24WB-3L	24" Built-in ADA Compliant wine reserve with stainless steel glass door hinge left
HA24WB-3R	24" Built-in ADA Compliant wine reserve with stainless steel glass door hinge right
HA24WB-4L	24" Built-in ADA Compliant wine reserve with integrated wood overlay glass door hinge left
HA24WB-4R	24" Built-in ADA Compliant wine reserve with integrated wood overlay glass door hinge right
Beverage Centers	
HA24BB-3L	24" Built-in ADA Compliant beverage center with stainless steel glass door hinge left
HA24BB-3R	24" Built-in ADA Compliant beverage center with stainless steel glass door hinge right
HA24BB-4L	24" Built-in ADA Compliant beverage center with integrated wood overlay glass door hinge left
HA24BB-4R	24" Built-in ADA Compliant beverage center with integrated wood overlay glass door hinge left
Clear Ice Maker	
H50IM-ADL	15" ADA-Compliant Clear Ice Maker with stainless steel door hinge left
H50IMS-ADR	15" ADA-Compliant Clear Ice Maker with stainless steel door hinge right
H50IMW-AD	15" ADA-Compliant Clear Ice Maker with wood overlay door hinge left or right

**24 in. Electrical:** 115V, 60Hz.  
1 Phase AC, 2.3 amps

**Plumbing:** None Required

**Shipping Weight:** 200 lbs.

**Refrigerated Volume:** 4.3 cubic ft.

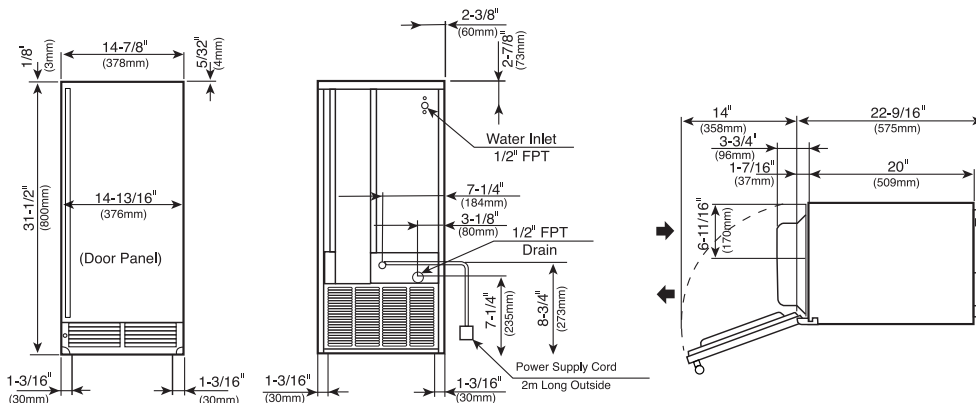
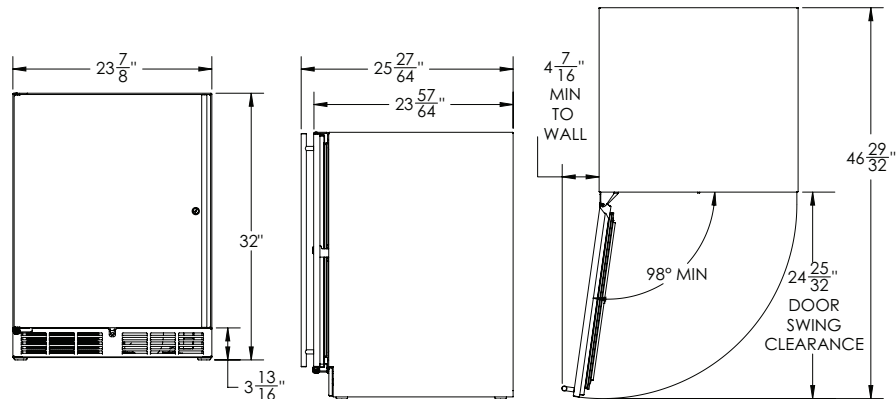

**15 in. Electrical:** 115V/60/1  
15 amp Max Fuse/HACR  
Breaker Size

**Plumbing:** 1/2" FPT Water Inlet  
1/2" FTP Drain

**Shipping Weight:** 115 lbs.

**Operating Limits**

- Ambient Temp Range: 45 - 100°F
- Water Temp Range: 45 - 95°F
- Water Pressure: 7 - 113psig
- Voltage Range: 104 - 127V

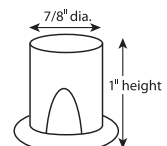

8300 W. Good Hope Rd. • Milwaukee, WI 53223  
1-800-558-5592 • Fax: (414) 353-7069 • www.Perlick.com  
Perlick is committed to continuous improvement. Therefore, we reserve the right to change specifications without warning