

# 24" Recessed Handle Special Application Black SGE63E06UC



## Features and Benefits

### Key Features

- 49 dBA- Quietest dishwasher in it's class
- ActiveTab™ Tray Optimizes Detergent Dissolving
- Variable Spray Pressure
- Water Softener Ensures Perfect Cleaning Results

### Design

- Stainless Steel EuroTub
- Silver Colored Fascia in Stainless Steel
- Red Remaining Time Display

### Performance

- 49 dBA- Quietest dishwasher in it's class
- 4 Wash Cycles and 2 Options
- Sanitize Option eliminates bacteria and enhances drying results
- Variable Spray Pressure
- ActiveTab™ Tray Optimizes Detergent Dissolving
- Water Softener Ensures Perfect Cleaning Results

### Efficiency

- Saves up to 599 gallons of water each year
- 239 kWh /yr - Energy Star®
- Exceeds ENERGY STAR Requirements by 35%
- EcoSense™ Reduces Energy Usage by up to 20%
- Half Load Option for Small Loads

### Convenience

- AquaStop® Plus 4-Part Leak Protection Works 24/7
- Multi-Function LED with Remaining Time
- 24 h Delay Start Timer



Notes: All height, width and depth dimensions are shown in inches. \*Please refer to installation instructions prior to making cutout. BSH reserves the absolute and unrestricted right to change product materials and specifications, at any time, without notice. Consult the product's installation instructions for final dimensional data and other details. Applicable product warranty can be found in a accompanying product literature or you may contact your account manager for further details.

For more information on our entire line of products, go to [boschappliances.com](http://boschappliances.com) or call 1-800-944-2904.

Copyright ©2014 BSH Home Appliances Corporation. All rights reserved. Bosch is a registered trademark of Robert Bosch GmbH.

Litho Date: 01/2014



# 24" Recessed Handle Special Application Black SGE63E06UC

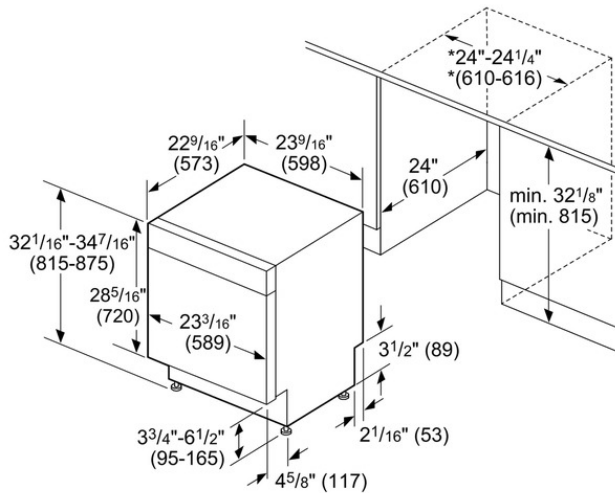

\* 23<sup>5</sup>/<sub>8</sub>" (600) without decor strips

measurements in inches (mm)

## Features

Watts (W)	1300
Current (A)	12
Volts (V)	120
Frequency (Hz)	60
Power Cord Length	47 1/4"
Minimum Water Pressure (lb/sin)	7.0
Length inlet hose (in)	55 1/8"
Length outlet hose (in)	55 1/8"
Overall appliance dimensions (HxWxD) (in)	32 1/16" x 23 9/16" x 24"
Required cutout size (HxWxD) (in)	32 1/16" x 24" x 24"
Adjustable feet	Yes

## Technical Specification

Number of wash cycles	5
Number of options	6
Third Rack	
Tub material	Stainless steel
Concealed heating element	Yes
Leak protection system	24/7 Aqua Stop Plus
Five-level wash	Yes
Water softener	Yes
ChildLock	
Total annual energy consumption (kWh)	234
Energy Efficiency Class	Tier 1
Energy Star® qualified	Yes
Total annual energy consumption (kWh)	477.3
Total annual water consumption (g)	477
Number of place settings	14

Drain hose:  
63" (160 cm)

Drain hose:  
59" (150 cm)

Water inlet hose:  
55" (140 cm)

Water inlet hose:  
47" (120 cm)

Electrical junction box:  
11<sup>3</sup>/<sub>4</sub>" (30 cm)

Electrical junction box:  
29<sup>1</sup>/<sub>2</sub>" (75 cm)

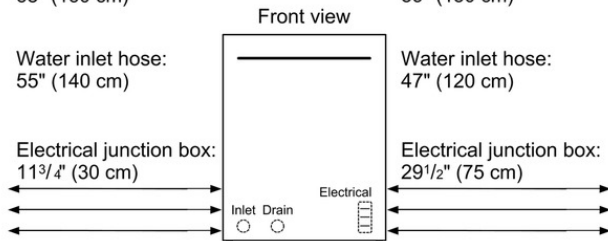

All connections are at the rear of the appliance.  
Extension for drain hose available as accessory.  
Power cord for connection to electrical outlet (3-prong plug)  
available as accessory.

Notes: All height, width and depth dimensions are shown in inches. \*Please refer to installation instructions prior to making cutout. BSH reserves the absolute and unrestricted right to change product materials and specifications, at any time, without notice. Consult the product's installation instructions for final dimensional data and other details. Applicable product warranty can be found in a accompanying product literature or you may contact your account manager for further details.

For more information on our entire line of products, go to [boschappliances.com](http://boschappliances.com) or call 1-800-944-2904.  
Copyright ©2014 BSH Home Appliances Corporation. All rights reserved. Bosch is a registered trademark of Robert Bosch GmbH.

Litho Date: 01/2014

