

USE AND CARE MANUAL

BUILT-IN DISHWASHER

For use with models EDW24S, MDW24S



Style varies, model MDW24S shown.

Table of Contents

Important Safety Instructions	1
Getting to Know Your Dishwasher	4
Loading Your Dishwasher	8
Operating Your Dishwasher.....	13
Care and Cleaning	15
Before You Call for Service.....	17
Warranty and Service	21
Notes	22
Warranty Card	Back Cover



To Our Valued Customer:

Congratulations on your purchase of the very latest in Dacor® products! Our unique combination of features, style and performance make us The Life of the Kitchen™, and a great addition to your home.

In order to familiarize yourself with the controls, functions, and full potential of your new Distinctive Appliance, we suggest that you thoroughly read this use and care manual, beginning with the **Important Safety Instructions** section.

All Dacor appliances are designed and manufactured with quality and pride, while working within the framework of our company value. Should you ever experience a problem with your product, please first check the **Before You Call for Service** section of this manual for guidance. It provides useful suggestions and remedies prior to calling for service.

Valuable customer input helps us to continuously improve our products and services, so please feel free to contact our Customer Service Team for assistance with any of your product support needs.

Dacor Customer Service Team
1440 Bridge Gate Drive
Diamond Bar, CA 91765

Telephone: (800) 793-0093
Fax: (626) 403-3130
Hours of Operation: Monday through Friday
6:00 A.M. to 5:00 P.M. Pacific Time
Web Site: www.Dacor.com

Thank you for choosing Dacor for your home. We are a company built by families for families and we are dedicated to serving yours. We are confident that your new Dacor product will deliver a high level of performance and enjoyment for many years to come.

Sincerely,

The Dacor Customer Service Team

Important Safety Instructions

INSTALLER: LEAVE THESE INSTRUCTIONS WITH THE APPLIANCE.

CUSTOMER: READ THIS USE AND CARE MANUAL COMPLETELY BEFORE USING THIS APPLIANCE. SAVE IT FOR FUTURE REFERENCE. IT CONTAINS IMPORTANT USE AND CARE INFORMATION. RETAIN YOUR SALES RECEIPT OR CANCELED CHECK. PROOF OF ORIGINAL PURCHASE DATE IS REQUIRED FOR WARRANTY SERVICE.

For service and warranty information see page 21.

If you have any questions (other than warranty questions), call:

Dacor Customer Service
Phone: (800) 793-0093 (U.S.A. and Canada)
Monday — Friday 6:00 A.M. to 5:00 P.M. Pacific Time

Web site: www.Dacor.com

Have the complete model and serial number for your appliance available. Open the door to reveal the model and serial number label. It is located on the side (see the diagram below). Write the numbers below for future reference.

Model Number _____

Serial Number _____

Date of Purchase _____

Since Dacor continuously improves the quality and performance of our products, we may need to make changes to the appliance without updating this manual.

Important Information About Safety Instructions

The **Important Safety Instructions** and warnings in this manual can't cover all possible problems and conditions that can occur. Use common sense and caution when installing, maintaining or operating this appliance.

Always contact the Dacor Customer Service Team about problems or conditions that you don't understand.

Safety Symbols and Labels

DANGER

Immediate hazards that **WILL** result in severe personal injury or death.

WARNING

Hazards or unsafe actions that **COULD** result in severe personal injury or death.

CAUTION

Hazards or unsafe actions that **COULD** result in minor personal injury or property damage.

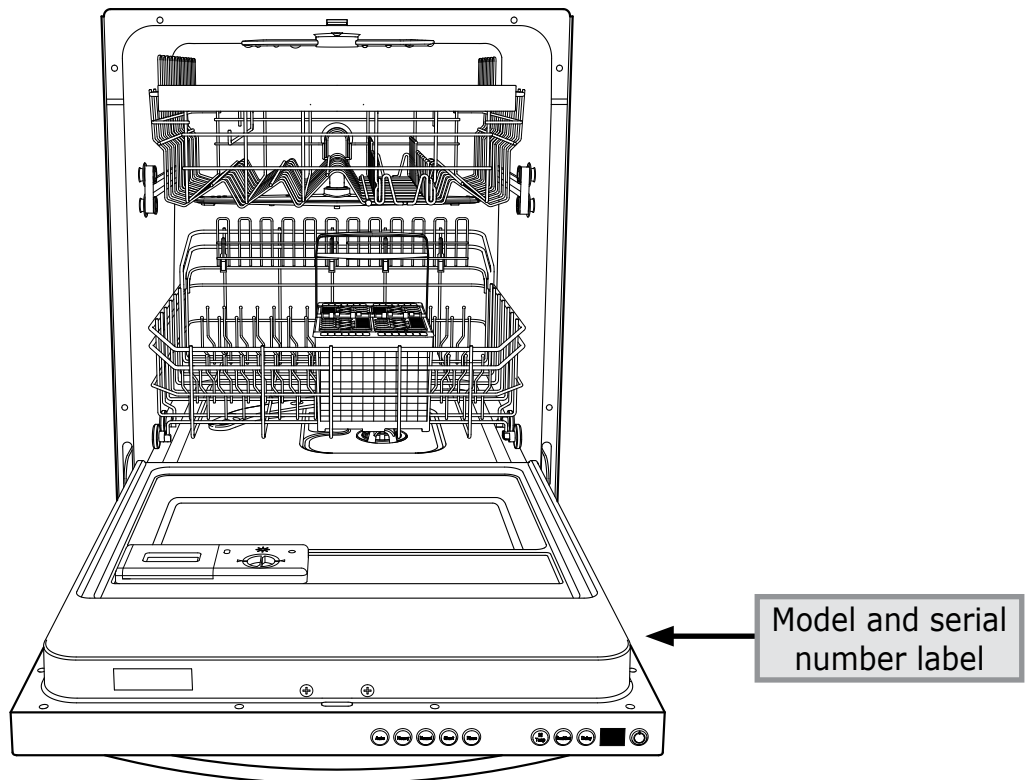

READ AND SAVE THESE INSTRUCTIONS

Important Safety Instructions

DANGER

IMPORTANT: Used appliances are dangerous, even if they are allowed to sit for only a short period of time. If you are getting rid of an old dishwasher, follow the instructions below to prevent injury or death due to child entrapment or suffocation.

Before you throw away your old appliance:

- Take off the door.
- Leave the racks in place so that children cannot easily climb inside.
- Cut the prongs off the power cable plug and discard them.
- Cut the power cable off and discard it separately from the old appliance.

IMPORTANT: To avoid the possibility of explosion or fire, do not store or use combustible, flammable or explosive liquids or vapors (such as gasoline) inside or in the vicinity of this or any other appliance.

General Safety Precautions

To reduce the risk of fire, electric shock, serious injury or death when using your appliance, follow basic safety precautions, including the following:

WARNING

- If you receive a damaged product, immediately contact your dealer or builder. Do not install or use a damaged appliance.
- Make sure that this dishwasher has been properly installed and grounded by a qualified installer according to the accompanying installation instructions. The dishwasher must be installed in a completely enclosed cabinet. Have the installer show you the location of the circuit breaker panel or fuse box so that you know where and how to turn off power to the dishwasher.
- Keep packaging materials away from children. Plastic sheets and bags can cause suffocation.
- Do not install, repair, or replace any part of the appliance unless specifically recommended in the literature accompanying it. A qualified service technician should perform all other service.
- Before performing any type of service, turn off power to the dishwasher at the circuit breaker panel or fuse box.
- Use this appliance only for its intended purpose, washing dish ware and cookware. It is not intended for commercial use.
- Do not operate the dishwasher unless all access panels are installed and the toe kick is in place. See the installation instructions accompanying the unit.
- Do not tamper with the controls.
- Make sure individuals who use the dishwasher are able to operate it properly.
- Never allow anyone, including children, to sit, stand or climb on any part of the appliance, including the door. Doing so may cause damage, serious injury, or death. Do not leave children alone or unattended in the area around the dishwasher. Do not allow children to play with the controls, pull on the handle, or touch other parts.
- Store all detergents and rinse aids out of the reach of children.
- Many surfaces within the dishwasher achieve high temperatures. Do not touch interior surfaces or items inside the dishwasher during or immediately after use.
- Exercise caution when opening the door. Let hot air or steam escape before looking or reaching into the wash compartment.
- During loading, insert all sharp or pointed objects with the handles up. Locate these items where they will not damage the door seal or cause personal injury.
- Use only the cleaning solutions specified in this manual to clean the dishwasher. Other cleaning solutions could produce dangerous fumes, cause corrosion of the metal parts and could permanently damage the finishes.
- Clean only those parts of the dishwasher listed in this manual. Clean them only in the manner specified.
- Under certain conditions hydrogen gas may be produced in a hot water system that has not been used for two weeks or more. Hydrogen gas is explosive. If the hot water system has not been used for a period of time, turn on all hot water faucets and let the water flow for several minutes to release any accumulated hydrogen gas. Do not smoke or use an open flame during this process.

Important Safety Instructions

CAUTION

- Use only detergents and rinse aids designed for use with a residential dishwasher.
- Use the dishwasher to wash flatware and cookware only. Washing other items may damage or discolor the dishwasher. Wash only the types of dishes and cooking utensils indicated in this manual.
- Do not wash plastic items unless they are marked "dishwasher safe." Always check the manufacturer's recommendation before washing plastic items that are not marked.
- To prevent household mold and mildew damage, periodically check the hot water supply line and drain hoses for leaks.
- If the dishwasher outlet is connected to a garbage disposal, make sure the disposal is completely empty before running the dishwasher.
- Always place large or heavy items in the bottom rack.
- To avoid damage to the racks, do not let sharp edges come into contact with them.
- To avoid breakage, make sure all glassware is secure before starting the dishwasher.

Getting to Know Your Dishwasher

❖ Control panel	Located on top of the door. The lighted buttons control your dishwasher. See page 6 for a description of the button functions. The display tells you important operating information. See page 7 for a description of the symbols that appear on the display.
❖ Detergent dispenser	Automatically releases the detergent during the wash part of the cycle (see page 11).
❖ Dish washing tub	The compartment where tableware and cookware are loaded for washing.
❖ Door switch	Located in the door. Automatically pauses dish washing when the door is opened.
❖ Filter system	Traps food and debris that could damage or plug up the mechanical parts of your dishwasher. See page 15 for cleaning instructions.
❖ Racks	The racks are coated with a durable coating that protects the finish of the loaded tableware and cookware. They have fold down tines and shelves to allow you to load various size dishes and flatware (see page 10). The height of the top rack is adjustable.
❖ Rinse aid dispenser	Automatically releases rinse aid during the rinse part of the cycle. Rinse aid is a fluid that helps the dishes dry properly and helps prevent water spots. The amount of rinse aid dispensed is adjustable (see page 12).
❖ Silverware basket	Use the silverware basket to hold silverware and kitchen utensils. It has two compartments that snap closed to hold small items and is removable (see page 8).
❖ Spray arms	The spray arms spray water on the dishes at high pressure to remove soil.
❖ Toe kick panel	Not shown. The toe kick panel covers the internal mechanics of the dishwasher. It is located behind the bottom of the door. It must always be in place during operation.

Getting to Know Your Dishwasher

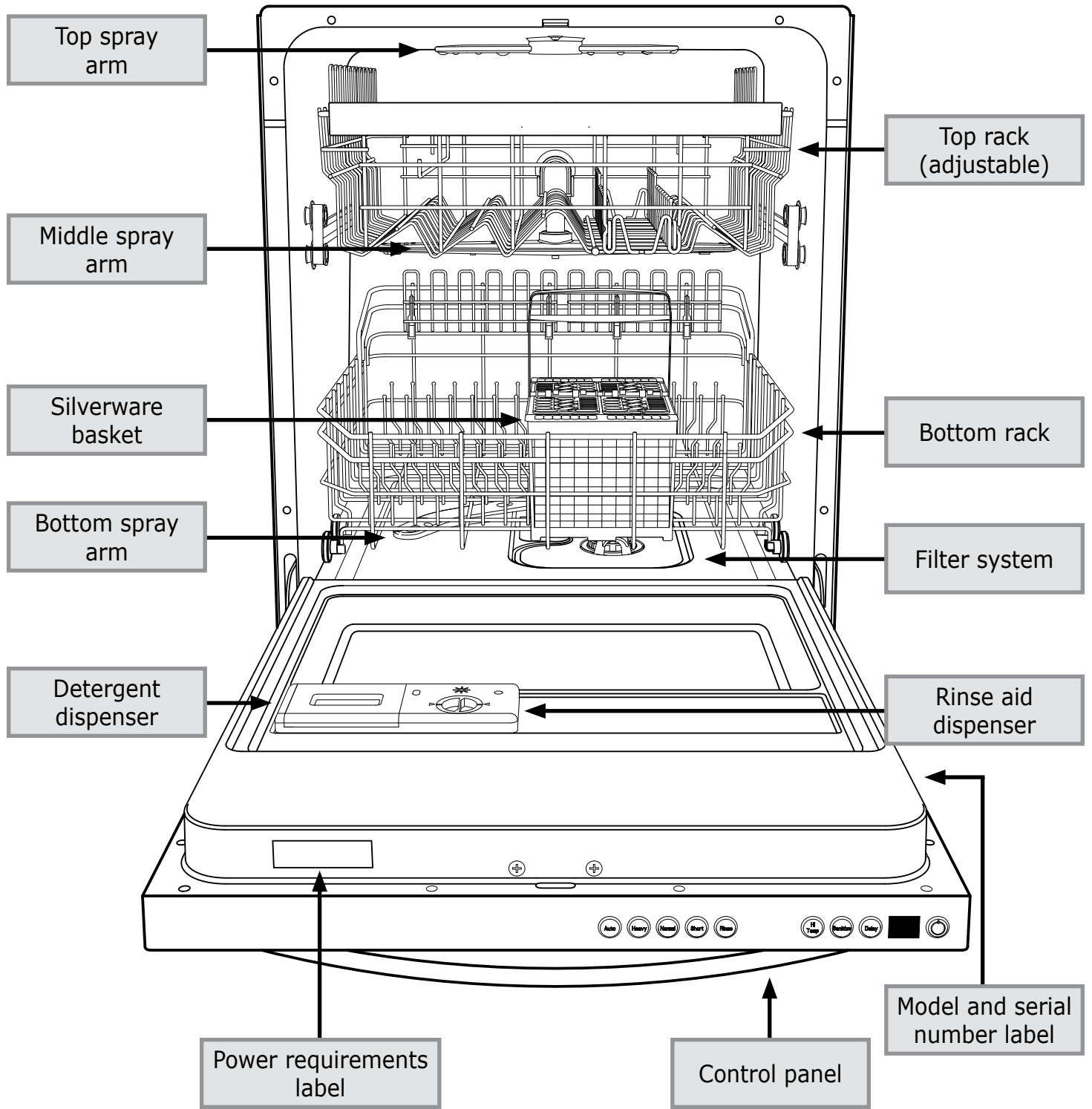

Getting to Know Your Dishwasher

Parts of the Control Panel

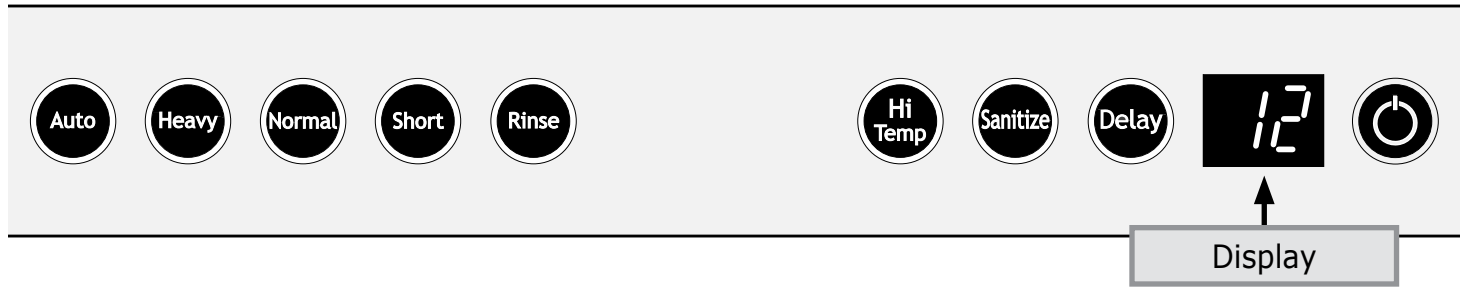

Wash Cycle Buttons



START/STOP button. Use this button to start the dishwasher after selecting a wash cycle or the rinse cycle (see page 13). It can also be used to pause the dishwasher in the middle of a wash or rinse cycle.



The **Auto-Wash** setting senses the size of the load and the amount of soil, then automatically selects the best wash cycle to clean the dishes and cookware properly. The cycle time is 72 to 96 minutes.



The **Heavy** wash setting is best for very dirty tableware and cookware. The cycle time is 90 to 96 minutes.



The **Normal** wash setting is best for normal soil on dishes and silverware. The cycle time is 78 to 96 minutes.



The **Short** wash setting is best for lightly soiled or pre-rinsed dishes and silverware. It is also good for lightly soiled items that have been pre-rinsed. The cycle time is 72 to 90 minutes.



Press the **Rinse** button if you want to run the rinse portion of the cycle only. The dry cycle will not run. Also, use this setting to rinse tableware that you do not want to wash right away. The cycle time is about 20 minutes.

Special Feature Buttons



When the **Hi-Temp** feature is selected, the water is heated to about 140 °F (60 °C) during the wash portion of the cycle. Washing at a higher temperature helps the detergent dissolve grease and grime better and the dishes dry more efficiently. It can be selected with any wash cycle, but not the **Rinse** cycle.



The **Sanitize** feature rinses the dish ware with rinse water heated to a temperature of 155 °F (68 °C) for maximum sanitization and drying (see page 14). It can be selected with any wash cycle, but not the **Rinse** cycle.



The **Delay** start feature allows you to set the dishwasher to start at a later time (see page 14).

Getting to Know Your Dishwasher

Display

The following symbols appear on the display during normal operation:



When the display shows a number between 1 and 24, it indicates the number of hours before the dishwasher will start because the **Delay** start feature is in use.



Stands for **CLOSE**. It means that a wash or rinse cycle has been started or is in process and that you need to close the door to continue operation.



Stands for **HOT**. It means that the water is heating in preparation for **Hi-Temp** or **Sanitize** operations.



Stands for **POWER FAIL**. It means that power to the appliance has been interrupted. It also appears when the dishwasher is first installed. Press **START/CANCEL** to clear the display.



Stands for **CLEAN FILTER**. It means that you need to remove and clean the filters. Once the filters are cleaned and replaced, the dishwasher will continue normal operation. (See **Care and Cleaning** on page 15.)



Chime feature is activated. Press the **Short** and **Rinse** buttons at the same time to turn the chime on and off.



Chime feature is de-activated. Press the **Short** and **Rinse** buttons at the same time to turn the chime on and off.



Appears when the rinse aid level is **LOW**. Add rinse aid. (See the **Rinse Aid Dispenser** section on page 12.)

Additional Features

- ❖ **Chime** A chime sounds to confirm that you have selected a wash cycle on the control panel. The chime also sounds when the cycle is complete.
- ❖ **Removable utensil shelf** Your dishwasher is equipped with a special removable shelf used to hold utensils during the wash cycle. See page 10.
- ❖ **Turbidity sensor** Automatically decreases or increases the wash and rinse time, as well as water usage, for more consistent cleaning and energy savings.
- ❖ **Temperature sensor** Continuously monitors and controls water temperature.

Loading Your Dishwasher

WARNING

To avoid injury, load all sharp or pointed objects with the handles up.

IMPORTANT

If the load will sit for a while before washing, run the **Rinse** cycle. Doing so will reduce the chance of food hardening or staining and damaging your dish ware and utensils.

IMPORTANT

- For best results, do not nest utensils.
- Do not load silver next to stainless steel. Damage to the silver may result.
- Put the basket in the bottom rack near the front, between the tines, as shown below.
- To prevent small, light items from falling out of the rack when sprayed with water, put small items, like corn cob holders, baby bottle caps, etc. into a compartment in the silverware basket and close the hinged cover.

What Can Be Washed

Items that you can safely wash in your dishwasher:

- Aluminum (except for disposables)
- China (except delicate china)
- Cookware with non-stick coatings
- Crystal (except antique crystal)
- Glass
- Plastic (dishwasher safe only)
- Silver and silver plate
- Stainless steel
- Stoneware

What Should Not Be Washed

For safety reasons, and to prevent damage, do not wash the following items in your dishwasher:

- Antique crystal
- Brass
- Bronze
- Cast iron
- Delicate china
- Disposable aluminum
- Disposable plastic items
- Flatware with bonded handles
- Gold
- Pewter
- Sharp kitchen carving knives
- Tin
- Wood

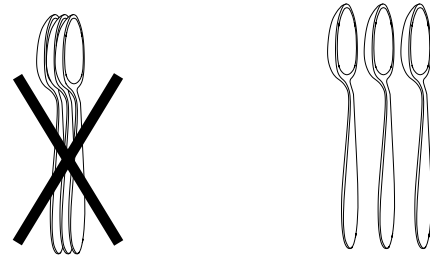

The Silverware Basket

Load the silverware basket first. Put the silverware and utensils, handle first, into the holes on the top. Load knives with the handles up. Open the hinged covers to load larger items and quantities. You can load the silverware basket while it is in the rack or you can load it before putting it in place.

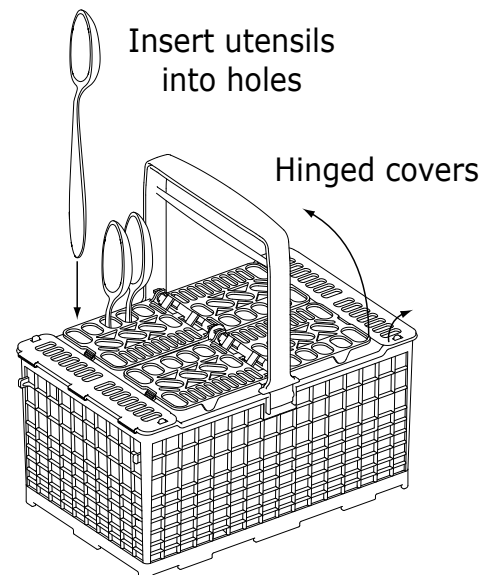
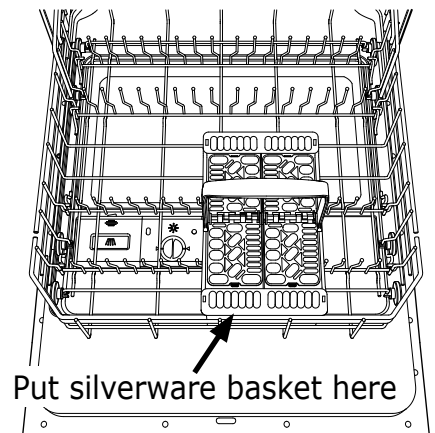

Loading Your Dishwasher

Loading the Racks



IMPORTANT

- It is best to place sharp objects in the silverware basket to prevent damage to the rack coating.
- The spray arms must spin freely. Do not allow items sticking out of the racks to block them.
- Raise the top rack to prevent objects on the bottom rack from blocking the middle spray arm.
- Do not load cookie sheets and large platters in the front of the bottom rack. Doing so will prevent water from dissolving the detergent in the detergent dispenser.
- After loading, push in firmly on the top rack. If you do not push the top rack completely into place, the middle spray arm may not work properly.

Before You Load the Racks

- Before loading the racks, scrape off leftover food items, and nonfood items like toothpicks and napkins.
- Empty liquids in glasses, cups, and pitchers into the sink.

Adjusting the Top Rack

- If there are large items in the bottom rack that could interfere with the middle spray arm, move the top rack to the high position. Otherwise, put the top rack in the low position.

To move the top rack from the low position to the high position:

- Grasp both sides of the rack and pull up until it stops.
- Let go of the rack. It will rest in the high position.

To move the top rack from the high position to the low position:

- Grasp both sides of the rack and pull up until it stops. The leveling mechanism will release.
- Gently lower the rack to the low position.

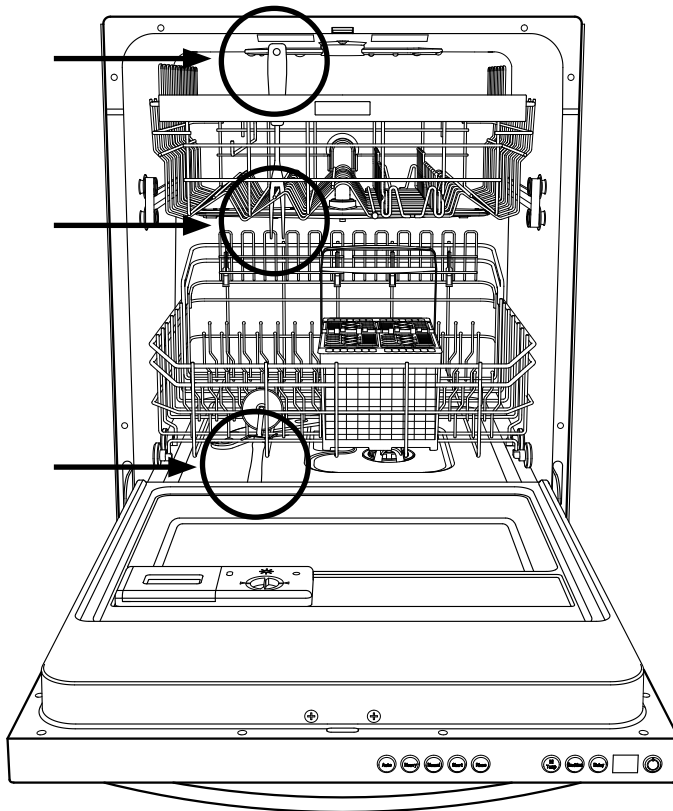

Do not allow items to stick out of top and bottom of racks that can block spray arms.

No cookie sheets, trays, platters etc. here

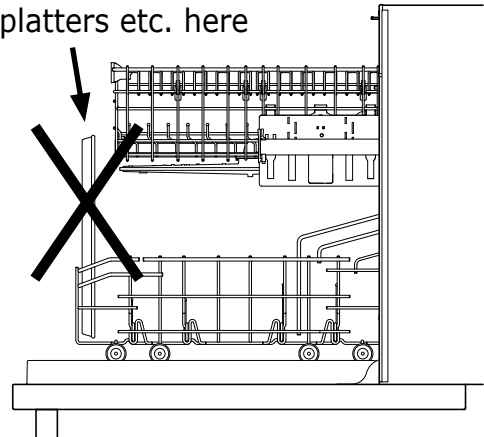

Do not block the front of the rack.

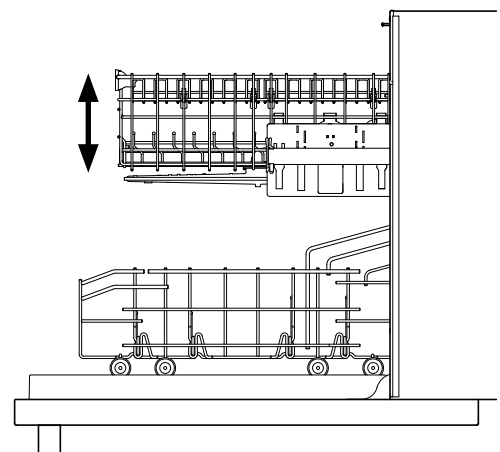

Top Rack Adjustment

Loading Your Dishwasher

During Loading

Always use the top rack for delicate items, such as glassware. Damage may occur if you put delicate items in the bottom rack.

- Large knives and utensils can be put in the removable utensil shelf or the fold down shelves on the sides of the top rack. To insert the removable utensil shelf, fit the hooks on the ends over the bars on the front and back of the top rack.

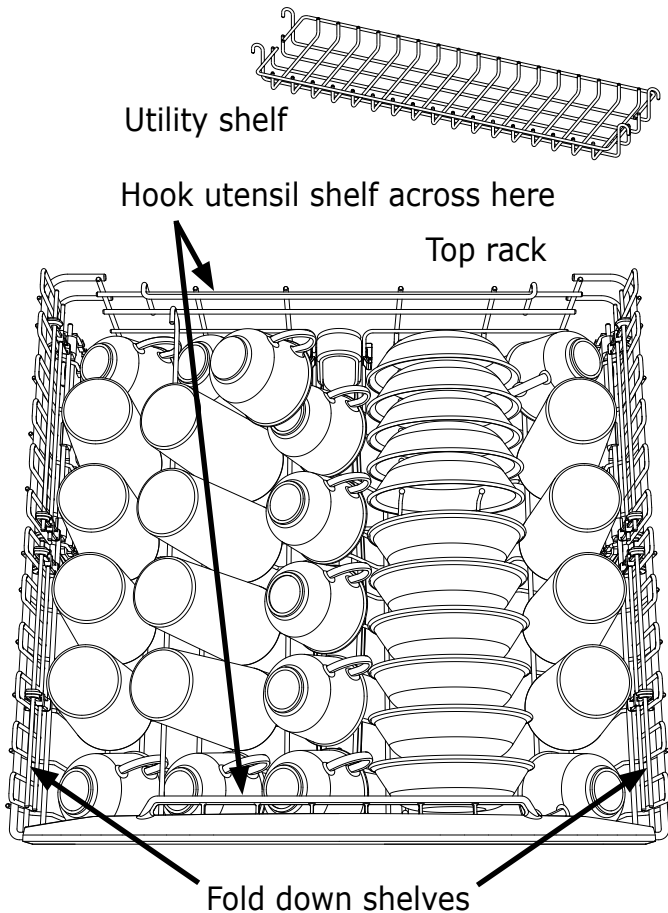

CAUTION

If the top rack is in the high position, the fold down shelves must be in the folded down position. Otherwise, damage to the dishwasher or the dishes may result when you push the rack into place.

- Always load large or heavy items (such as pots, pans, and large dish ware) in the bottom rack.
- Do not stack dishes, glasses or pots and pans. Stacking will prevent water from getting to soiled surfaces.
- Load all items so that the open ends face down as much as possible. Good drainage provides the best drying. It is not necessary to rinse objects before loading them.
- To minimize breakage and chipping, secure all glassware and other breakables in the tines. Do not allow fragile items to touch each other.
- To minimize noise, do not allow pots and pans to touch and keep large items from touching the sides of your dishwasher.

Bottom rack

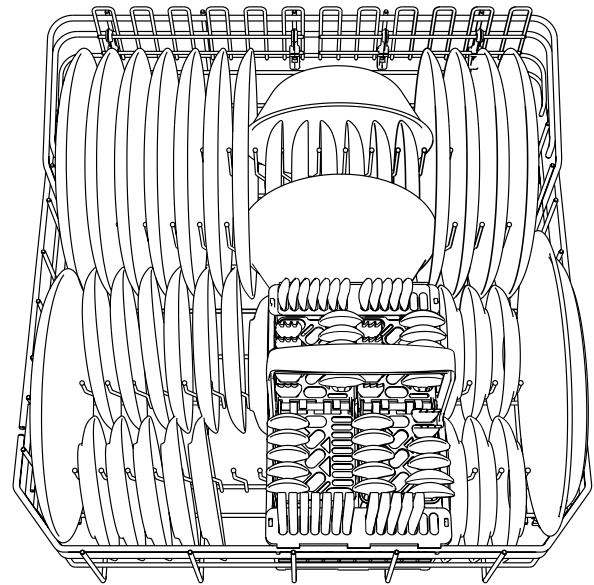

- You may lower the rack tines, if necessary, to allow you to fit large or bulky items into a rack. To lower a set of tines, pull up and swivel to the side.

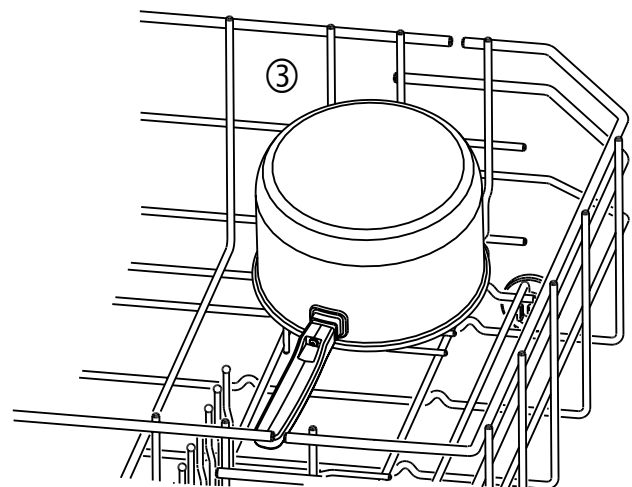
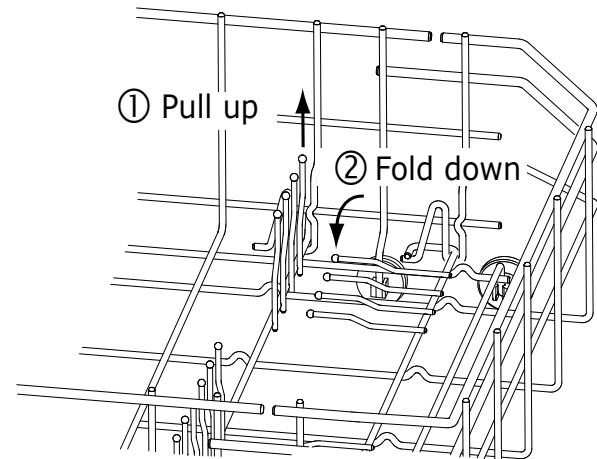

Loading Your Dishwasher

The Detergent Dispenser



IMPORTANT

- Do not use hand dish washing detergents. They will create excessive foaming that interferes with proper operation.
- To make sure the detergent dissolves properly, fill the detergent dispenser just prior to starting your dishwasher. Detergent will harden if it sits too long.
- Store dry detergent in a cool dry place to prevent caking.
- Use a liquid rinse aid for best results (See page 12).

The detergent dispenser has three compartments, the prewash compartment on the outside lid, and two in the main wash compartment. It does not matter which main wash cup you load first.

The pre-wash compartment empties into the dishwasher when the door is closed. The main wash compartment releases detergent automatically during the main wash cycle.

To fill the detergent dispenser:

1. If the detergent dispenser lid is closed, press the release button to open it.
2. See the **Detergent Table** for the amount of detergent to use in the main wash cup. The amount of detergent required depends on the hardness of the water in your area. Harder water requires more detergent. Water hardness is measured in grains per gallon (gpg). Do not use too little detergent for your water hardness. Doing so can cause poorly cleaned dishes, filming or spotting. If you use too much detergent, you can cause a permanent film called etching. To find out the water hardness in your area, contact your water company.

DETERGENT TABLE			
Soft Water (0-3 gpg)	Medium (4-8 gpg)	Hard Water (9-12 gpg)	Very Hard Water (12 gpg or more)
2 teaspoons	5 tea- spoons	8 teaspoons	Fill main wash cup completely

3. After filling the main wash compartment, close the dispenser lid.
4. Fill the pre-wash cup (on the lid) to the top.
5. Close the dishwasher door.

If you have very hard water:

Detergent alone may not be enough for water hardness above 12. For maximum cleanliness you may need to use a water softener. Or you may add additional detergent about 20 minutes after starting your dishwasher. As a rule, add one teaspoon for each grain above 12.

1. Open the door. The dishwasher will stop operating.
2. Wait a moment for the steam to clear.
3. Without touching any of the hot surfaces or racks, pour additional dish washing detergent into the bottom of the dish washing tub.
4. Close the door. Push on the door handle to make sure that the door is completely shut. After a short pause, operation will resume.

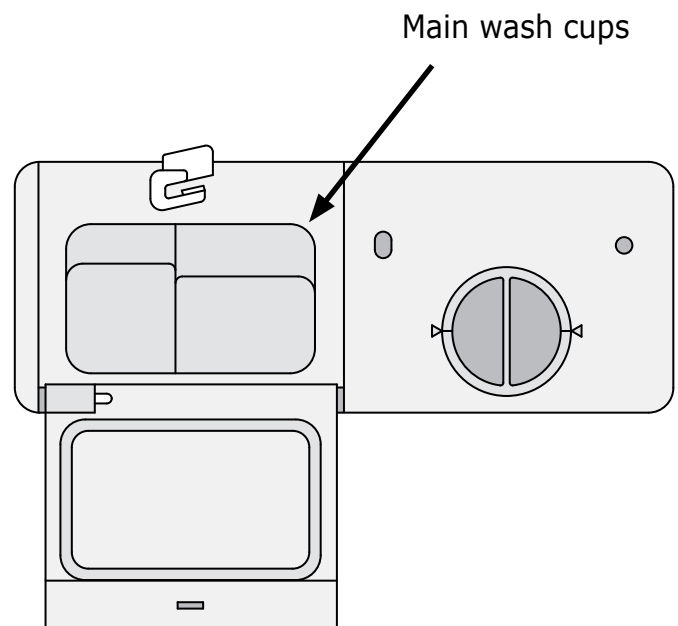
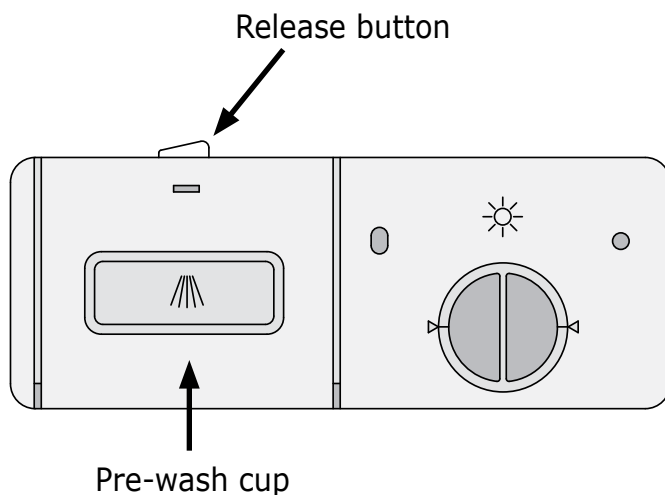

Loading Your Dishwasher

The Rinse Aid Dispenser

Rinse aid is important to the drying process of the dish ware. Its sheeting action also reduces spotting. Dacor recommends that you keep the rinse aid dispenser full and properly adjusted (see below) at all times.

A rinse aid containing citric acid may be used to remove the white or gray film caused by very hard water.

The rinse aid indicator on the dispenser turns dark when full and clear when it is time to refill. Also, the display will read **LO** at the end of the dish washing cycle when it is time to refill.



To refill the rinse aid dispenser:

1. Turn the rinse aid cap counterclockwise 1/4 turn and lift it out.
2. Slowly pour the rinse aid into the filler hole until the indicator turns dark. Do not overfill.
3. Wipe up any spillage with a damp rag.
4. Replace the rinse aid cap and turn it clockwise to the closed position.

Adjusting the Rinse Aid Dispenser

The rinse aid dispenser must be properly adjusted. Too little rinse aid will allow spotting and drying problems. Too much rinse aid will cause foaming and streaking.

The rinse aid setting is located under the rinse aid cap.

To change the setting:

1. Remove the rinse aid cap.
2. If you have spotty or improperly dried dishes, move the rinse aid setting a little higher. If you have streaks on your dishes, move the rinse aid setting a little lower. The harder the water, the more rinse aid required for acceptable results.
3. Replace the cap.
4. Check the dishes after the next wash load. Continue adjusting the rinse aid dispenser up or down according to the guidelines above until you have spot free, streak free, dry dishes.

If you have very soft water and still experience streaking when the dispenser is set to 1, you can dilute the rinse aid with water before pouring it into the dispenser to get acceptable results.

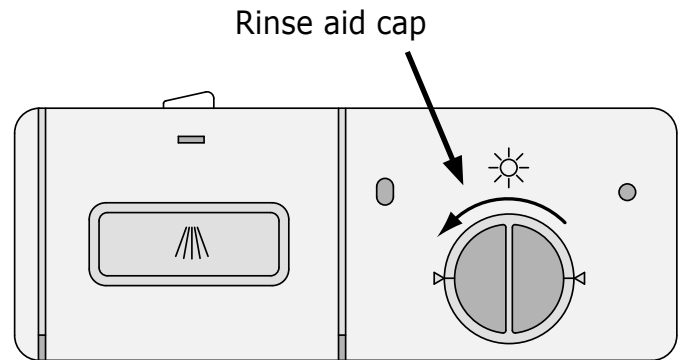

Pour rinse aid in hole

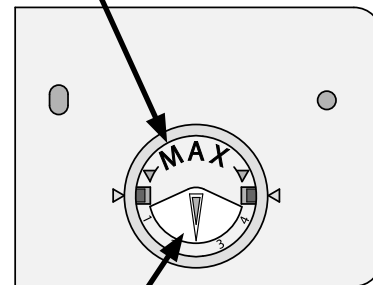

Rinse aid level adjustment

Operating Your Dishwasher

Starting Your Dishwasher

CAUTION

If the dishwasher drain line is connected to a garbage disposal, run the disposal and make sure it is completely empty before starting the dishwasher.



IMPORTANT

See the **Getting to Know Your Dishwasher** section for a description of the various wash settings.

To wash or rinse the dishes:

1. Make sure you have loaded the dishwasher and that the detergent and rinse aid dispensers are filled according to the previous pages.
2. For best operation, clear the house pipes of cold water by running a nearby faucet until the water is hot.
3. Open the door.
4. Press one of the wash cycle buttons or the **Rinse** button on the control panel until it lights.



5. Press **START/CANCEL**. The **START/CANCEL** button will light and the display will show **CL** (meaning "close the door").  
6. Close the door.
7. Push on the door handle to make sure that the door is completely shut. After a brief pause, the dishwasher will start.
8. When the wash or rinse cycle is completed, the chime will sound.

While the dishwasher is operating:

- The dishwasher starts each cycle by draining any water at the bottom of the wash tub.
- You may hear the bottom of the tub fill with clean water and the pulsating sound of water spraying on the dishes and the tub walls.
- The number of tub drains and fills and the amount of spraying depends on the wash or rinse cycle selected. The dishwasher may appear to pause from time to time while it is heating water to a higher temperature.
- During the wash/rinse cycle, the control panel buttons are not lit.
- If you open the door during the wash cycle, the dishwasher will stop operating. When you close the door, it will continue with the current cycle (after a short pause) until it is done.

Adding a Dish After You Start

You can add a dish, if needed, after starting your dishwasher. Dacor recommends that you only add items during the first five minutes of operation to make sure they get clean.

To add a dish:

1. Open the door. The dishwasher will stop operating.
2. Wait a moment for the steam to clear.
3. Without touching any of the hot surfaces or racks, insert the item into one of the racks, following normal loading instructions.
4. Close the door.
5. Push on the door handle to make sure that the door is completely shut. After a short pause, operation will resume.



Stopping Your Dishwasher During Operation

To stop the current cycle and drain your dishwasher:

1. Open the door. The dishwasher will stop operating.
2. Press **START/CANCEL**.
3. Close the door. After a short pause, you will hear the water in the dishwasher begin to drain. Once the water is drained, the dishwasher will turn off. 

The Hi-Temp Feature

If you want to wash at a high temperature for maximum grease and grime removal:

1. Open the door.
2. Press one of the wash cycle buttons on the control panel.
3. Press **Hi-Temp**. The **Hi-Temp** button will light (Pressing **Hi-Temp** a second time will turn it off again). 
4. Press **START/CANCEL**.
5. Close the door. After a short pause, the dishwasher will start. 

IMPORTANT

Hi-Temp cannot be selected with the rinse cycle.

Things to Know about the Hi-Temp Feature

- The **Hi-Temp** feature may increase the wash cycle time.
- **HO** may appear on the display while the dishwasher heats the water for the high temperature wash. 
- In addition, you can select the **Sanitize** feature also by pressing the **Sanitize** button before pressing **START/CANCEL**.

Operating Your Dishwasher

Starting Your Dishwasher (Cont.)

The Sanitize Feature

If you want a high temperature rinse after the wash cycle for maximum sanitization:

1. Open the door.
2. Press one of the wash cycle buttons on the control panel.
3. Press **Sanitize**. The **Sanitize** button will light (Pressing **Sanitize** a second time will turn it off again).
4. Press **START/CANCEL**.
5. Close the door. After a short pause, the dishwasher will start.



IMPORTANT

Sanitize cannot be selected with the rinse cycle.

Things to Know about the Sanitize Feature

- The **Sanitize** feature increases the wash cycle time.
- **HO** will appear on the display while the dishwasher heats the water for the high temperature rinse.
- In addition, you can select the **Hi-Temp** feature by pressing the **Hi-Temp** button before pressing **START/CANCEL**.



The Delay Feature

To set your dishwasher to start automatically at a later time:

1. Press one of the wash cycle buttons or the **Rinse** button.
2. If you have selected a wash cycle, you may press the **Hi-Temp** or **Sanitize** feature buttons for higher wash temperature or maximum sanitization.
3. Repeatedly press the **Delay** button until the number of hours you want to delay operation appears on the display. You can delay the start of your dishwasher up to 24 hours.
4. After selecting the delay time, press **START/CANCEL**.
5. Close the door. The dishwasher will start after the selected number of hours.



To cancel the delay function:

1. Open the door.
2. Press **START/CANCEL** once to make the dishwasher start when you close the door. Press **START/CANCEL** twice to turn the dishwasher all the way off.

The Cycle Memory Feature

Your dishwasher remembers the settings for the last cycle it ran.

If you want your dishwasher to run the same cycle as it ran the previous time:

1. Open the door.
2. Press the **START/CANCEL** button (without pressing a wash/rinse cycle button first). The display will read **CL** telling you to close the door.
3. Close the door.
4. Push on the door handle to make sure that the door is completely shut. After a short pause, the dishwasher will begin to operate.



NOTE: If the delay feature was used during the previous cycle, the dishwasher will start after the number of hours originally selected.

Turning the Chime On or Off

To turn the chime on or off:

1. Open the door.
2. Press the **Short** and **Rinse** buttons at the same time.
3. **OF** will appear on the display when you turn the chime off.
4. **On** will appear on the display when you turn the chime back on.
5. Close the door.



Care and Cleaning

Filters and Strainer Baskets

CAUTION

Do not operate the dishwasher without the strainer and the two filters in place. The strainer and filter system is designed to keep large food particles out of the mechanical parts.

Clean the filters and strainer periodically to keep your dishwasher working efficiently. When the filters begin to clog, **CF** will appear on the display. This warning indicates that the filters need to be cleaned immediately.



To clean the filters:

1. Pull the bottom rack out of the dishwasher.
2. Remove the strainer and small particle filter by turning the handle counterclockwise and lifting it straight up.
3. Push in on the tab on the strainer to remove it.
4. Lift the medium particle filter out of the floor of the wash tub.
5. Rinse off and clean the filters and strainer in the kitchen sink with a soft sponge and mild kitchen detergent under warm water.

To replace the filter system:

1. Put the medium particle filter on the floor of the tub. Fit it into the dimpled area.
2. Reconnect the strainer to the top of the small particle filter.
3. Put the small particle filter and strainer into the hole in the bottom of the tub. Tighten clockwise.

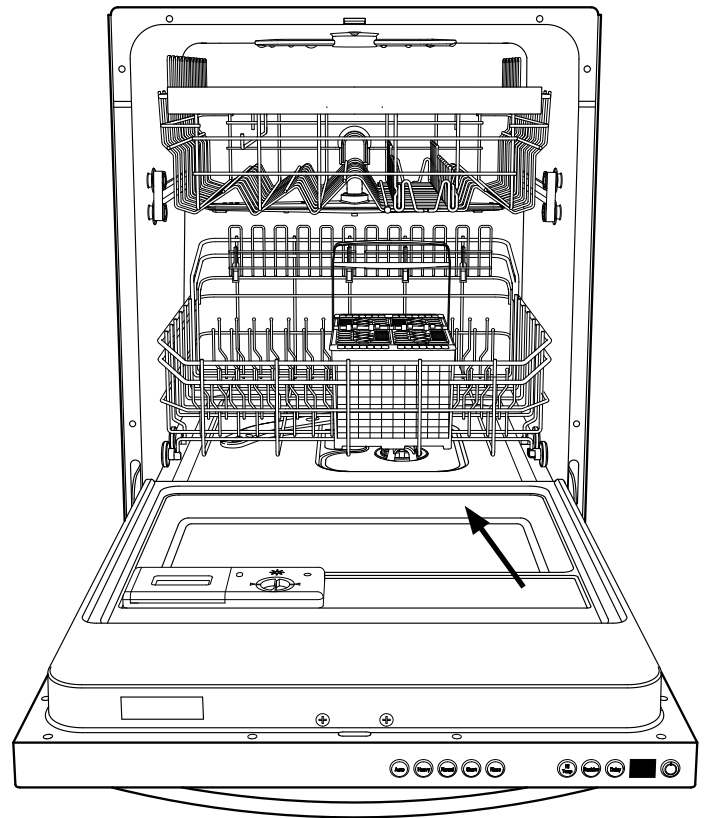

Filter and Strainer Location

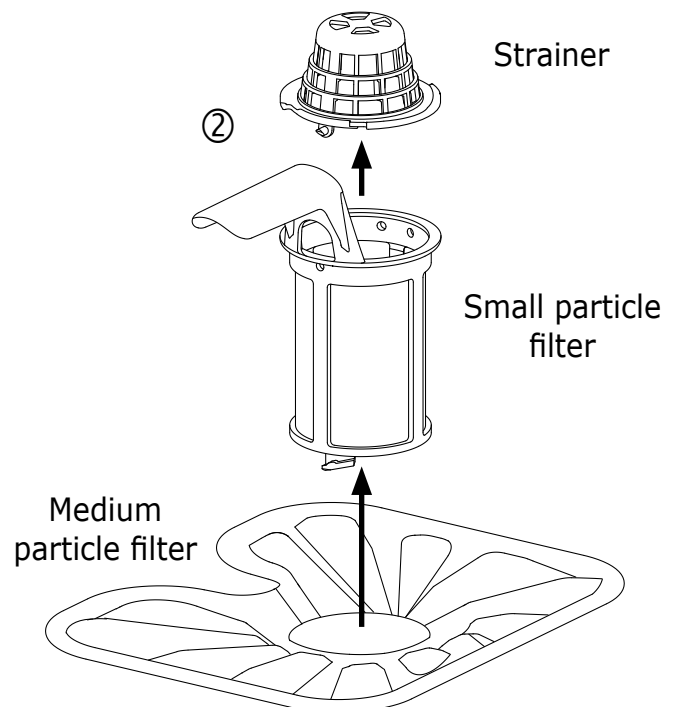
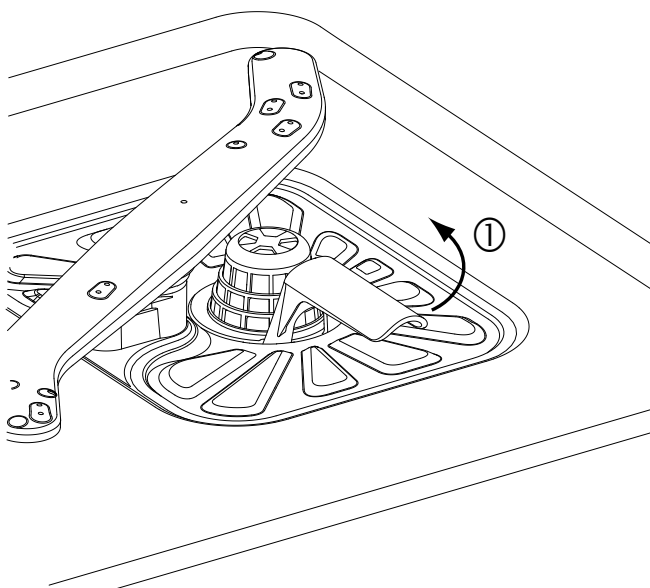

Filter Removal

Care and Cleaning

Cleaning the Interior Surfaces

CAUTION

Exercise caution when cleaning around the control panel area. Do not use spray cleaners of any kind on these surfaces.

- The dish washing tub of your Dacor dishwasher is constructed of high quality stainless steel. It remains clean during normal use.
- The control panel, the racks and areas where food particles may become lodged, may be wiped clean, if necessary, with a soft damp rag.
- Food particles on the silverware basket can be rinsed clean under a faucet with warm water.

Cleaning the Exterior Surfaces

CAUTION

Always wipe stainless steel surfaces with the grain.

- Clean exterior surfaces with a solution of mild detergent and warm water using the soft side of a sponge. Rinse and dry with a soft, lint-free cloth.
- You may also use Dacor Stainless Steel Cleaner (Dacor part number A302) on stainless steel surfaces. Use it according to the directions on the package.

Draining the Air Gap

Some local building codes require the dishwasher to have a drain air gap installed on the drain line. A drain air gap is usually mounted on top of the sink. If it becomes plugged or dirty, the dishwasher will not drain properly. Remove the cover and inspect the air gap every time you clean the filter and strainer.

To inspect the drain air gap:

1. Remove the cover.
2. Check to make sure it is clean.

NOTE: The drain air gap is not part of your dishwasher and is not covered by the warranty.

Winter Care

CAUTION

Freezing temperatures may cause water lines to rupture. To avoid damage to the dishwasher and its surroundings, make sure all water lines to and within the dishwasher are protected.

To protect it from damage caused by freezing, winterize a dishwasher left in an unheated place during cold weather.

NOTE: Only a qualified person should do the following.

To disconnect service:

1. Turn off electrical power to the dishwasher at the supply source by removing fuses or turning off the circuit breaker.
2. Shut off the water supply.
3. Place a pan under the inlet valve. Disconnect the water line from the inlet valve and drain the water into a pan.
4. Disconnect the drain line from the pump and drain the water into a pan.

To restore service:

1. Reconnect the water, drain and electrical power supply.
2. Turn on the water and electrical power supply.
3. Fill both detergent cups and run the dishwasher through a **HEAVY** wash cycle.

See your installation instructions for more details.

Before You Call for Service

Problem Solution Guide

PROBLEM	MAY BE CAUSED BY	WHAT TO DO
Display: Unusual symbol appears.	See the Display section on page 7.	
Spotting and filming.	Hard water.	Use maximum recommended amount of dishwasher detergent.
		You may need a home water softener.
		To remove hard water spots, try a vinegar rinse: <ul style="list-style-type: none"> • Wash and rinse load as usual. • Remove all metal items from dishwasher. Do not add detergent. • Pour two cups of vinegar into a bowl and set it on bottom rack. • Run dishes through an entire wash cycle. If the vinegar rinse does not work, repeat process substituting ¼ cup of citric acid crystals (available at most drug stores) for the vinegar.
		Wiping metal items with a damp cloth should remove spots. For sterling and silver plated flatware, rub with a towel, or use a good cream silver polish.
	Garbage disposal or sink trap full.	Run garbage disposal to eliminate food and obstructions in sink. Make sure sink drains properly.
	No rinse aid.	Make sure rinse aid dispenser is full.
	Water not hot enough.	Check hot water supply temperature. Minimum recommended incoming temperature to the dishwasher is 120 °F.
	Too little water.	Make sure water valve is fully open. Make sure that water pressure is between 20 and 120 p.s.i. and flow rate is a minimum of 1.0 gpm.
	Incorrect use of dishwasher detergent.	Use only correct amount of dishwasher detergent according to water hardness (see page 11) and the wash program selected. Fill dispenser only when ready to start the dishwasher. Do not use old or caked detergent. Store dishwasher detergent in dry place and in a closed container. Change the dishwasher detergent if results are still poor.
	Items not loaded properly or overloaded.	Make sure dishwasher is loaded according to instructions (see page 9). Do not overload. Make sure spray can reach all soiled surfaces.
Spray arms do not rotate properly.	Make sure that both spray arms rotate freely. Make sure that items do not obstruct movement of spray arms. If necessary, clear any obstructions.	
Strainer blocked.	Check strainer. Clean if necessary.	
Excessive foam in machine.		Use only dishwasher detergent.
		Too much rinse aid in final rinse cycle. Adjust rinse aid dispenser (see page 12).
Flatware incorrectly loaded.	Make sure items are not nested (see page 8).	
Small particles deposited on items.	Spray arms do not rotate properly.	Make sure that both spray arms rotate freely. Make sure that items do not obstruct movement of spray arms. If necessary, clear any obstructions.
		Make sure holes in spray arms are not blocked. If necessary, clear holes with a pointed object and rinse under water.

Before You Call for Service

Problem Solution Guide (Continued)

PROBLEM	MAY BE CAUSED BY	WHAT TO DO
Small particles deposited on items (cont).	Incorrect detergent use.	Use only correct amount of dishwasher detergent according to water hardness (see page 11) and the wash program selected. Fill dispenser only when ready to start the dishwasher. Do not use old or caked detergent. Store dishwasher detergent in dry place and in a closed container. Change the dishwasher detergent if results are still poor.
	Filter system.	Make sure filter system is clean and properly installed.
	Low water pressure.	Check that water valve is fully open. Make sure water pressure is between 20 and 120 p.s.i. and flow rate is 1.0 gpm minimum.
	Water not hot enough.	Check hot water supply temperature. Minimum recommended incoming temperature to the dishwasher is 120 °F.
	Items not loaded properly or overloaded.	Make sure dishwasher is loaded according to instructions (see page 9). Do not overload. Make sure spray can reach all soiled surfaces.
	Incorrect wash cycle selected.	Select a wash cycle with a longer wash time.
	Hard water.	See Detergent Table on page 11.
Detergent left in detergent compartment.	Detergent dispenser lid not opening.	The lid may not be opening. Check for items blocking it.
	Old detergent.	Do not use detergent that is hard or caked in the box. Use only fresh detergent. Add detergent to dishwasher just before starting it.
	Spray arms do not rotate properly.	Make sure that both spray arms rotate freely. Make sure that items do not obstruct movement of spray arms. If necessary, clear any obstructions. Make sure top rack is pushed in all the way so that spray arm on rack connects to nozzle on back wall.
		Make sure holes in spray arms are not blocked. If necessary, clear holes with a pointed object and rinse under water.
Cycle not complete.	Close door, wait for cycle to complete.	
Chipping or breaking of glass-ware.	Improper loading.	Do not overload. Load between rack prongs, not over them. Glasses loaded over prongs will not be supported and may chip or break. Always use the top rack for delicate items. Dacor recommends that you wash fine china and crystal by hand.
Unusual noise.	Improper loading.	Utensils may not be secure or something small may have dropped from the rack. Water may cause utensils to rattle. Make sure dish ware is secure.
Water in bottom of dishwasher tub near filters.	Dish washing cycle not complete.	Close door. Allow cycle to finish.
	Some water in strainer is normal.	Some water in strainer portion of filter at end of cycle is normal.
	See Dishwasher does not drain properly below.	
Dishwasher does not drain properly.	Air gap plugged.	Be sure the air gap is not blocked or plugged. The air gap is a vent located on top of the sink. It is connected to the dishwasher. It is required by some local codes.
	Drain hose kinked.	Check drain hoses. Make sure they are not kinked.
	Filter(s) clogged.	Check and clean filter(s) if necessary. See page 15.

Before You Call for Service

PROBLEM	MAY BE CAUSED BY	WHAT TO DO
Water backs up in sink when dishwasher drains.	Garbage disposal or sink trap full.	Run garbage disposal to eliminate food and obstructions in sink. Make sure sink drains properly.
Dishwasher won't run.	Blown fuse or tripped circuit breaker.	Replace fuse or reset circuit breaker. Remove other appliances from the circuit.
	Door not completely closed.	Push in on door handle until you hear a click.
	Controls not set.	Make sure dishwasher is on (see page 13).
	Delay feature is on.	Wait for cycle to start (see page 14) or press the START/CANCEL button.
	Water supply off.	Check water supply valve. Turn on if necessary.
	Dishwasher not connected to power.	Have installer connect the dishwasher to electric power according to the installation instructions.
	Water supply line kinked.	Make sure water inlet hose is not kinked.
	No water in system.	Add 1/2 cup of water to bottom of the wash tub and start again.
Distortion of plastics.	Plastic item(s) not dishwasher safe.	Do not wash plastic items that are not labeled "dishwasher safe."
Delay feature will not work.	Door not closed completely.	Push firmly in on door handle until it "clicks."
Dishes not dry.	No rinse aid.	Fill rinse aid dispenser. Rinse aid helps dishes to dry faster.
	Plastic items.	Certain plastic materials are difficult to dry. Plastics may need to be towel dried.
	Improper loading or unloading.	Do not overload or nest items. Load according to instructions. See page 9.
	Water not hot enough.	Dishes washed with the Sanitize setting will dry the fastest.
	Dry cycle interrupted.	Door opened too soon. Make sure dry portion of cycle is complete before opening door.
	Concave bottom cups.	Cups with a concave bottom will collect water.
Cycle takes a long time.	Cycle may be in water heating delay.	Wait for water to heat.
	Delay feature is on.	Wait for cycle to start (see page 14) or press the START/CANCEL button.
	Sanitize feature is on.	Wait for Sanitize cycle to complete or press START/CANCEL button.
Dishwasher has an undesirable odor.	Dirty dishes left in dishwasher too long.	Run rinse or wash cycle.
	Standing water in bottom of wash tub.	See Water in bottom of dishwasher tub on page 18.
Marks and discoloration.	Aluminum utensils rubbing against items during wash cycle.	Be sure aluminum utensils, especially light weight, foil-type pans, do not touch dishes.
Yellow or brown marks.	Iron or manganese in water.	To remove spots, use a non-abrasive cleaner.
		Temporary solution: Pour a teaspoon to tablespoon of citric acid crystals in place of the pre-wash detergent in the detergent dispenser. Follow this pre-wash with a full detergent wash. Use the heavy wash program.
		Permanent solution: Install an iron removal system in the water supply.
	Washing copper with sterling silver.	Yellow film on sterling silver results when you wash copper utensils in same load. Silver polish will usually remove this type of stain.
	Tea or coffee (tannic acid) stains.	Remove tea or coffee stains by hand using a solution of 1/2 cup bleach and 3 cups warm water. (Do not use on sterling silver or silver plate).

Before You Call for Service

Problem Solution Guide (Continued)

PROBLEM	MAY BE CAUSED BY	WHAT TO DO
Discoloration of stainless steel or silver plate	Allowing salty or acidic foods to remain on flatware can damage them.	Rinse flatware that is to stand several hours before washing.
	Stainless steel contacting silver.	Direct contact to stainless steel can cause permanent damage to silver. Put silver and stainless steel in different silverware basket compartments.
		Do not put stainless steel and silver flatware in the same compartment.
		Do not use abrasives on stainless steel or silver.
Marks on melamine and plastics.	Porous material	Use special cleaner for plastic.
Cloudy film on glassware, etching of glass.	Too much detergent, especially in soft water.	Do not use bleach or scouring powder on these materials.
		To remove cloudy film, try a vinegar rinse: <ul style="list-style-type: none"> • Wash and rinse load as usual. • Remove all metal items from dishwasher. Do not add detergent. • Pour two cups of vinegar into a bowl and set it on bottom rack. • Run dishes through an entire wash program. If the vinegar rinse does not work, repeat process substituting ¼ cup of citric acid crystals (available at most drug stores) for the vinegar.
		If vinegar or citric acid rinse does not remove film, the cloudiness is "etching." This is permanent. To prevent etching, if you have soft water, try using only one teaspoon of recommended dishwasher detergent.
		Use a good quality dishwasher detergent and rinse-aid. Do not overload dishwasher. Water should circulate freely to assure adequate rinsing and draining.
	Rinse aid used with soft water.	Set rinse aid levels to minimum.
Sanitize button light does not come on at the end of cycle when Sanitize feature is selected.	Water not hot enough.	Check hot water supply temperature. Minimum recommended incoming temperature to the dishwasher is 120 °F.

Warranty and Service

Getting Help

Before you request service, please review the **Before You Call for Service** section on page 17. If you have performed the checks in the **Problem Solution Guide** and the problem has not been remedied, please contact us at one of the numbers below. Prior to requesting service, it is helpful to be familiar with the warranty terms and conditions listed in the **Warranty** section below.

For warranty repairs, call:

Dacor Distinctive Service:

Phone: (877) 337-3226 (U.S.A. and Canada)
Business Hours: 6:00 a.m. - 4:00 p.m. Pacific Time

For a list of Dacor service agents for non-warranty repairs:

Dacor Customer Service:

Phone: (800) 793-0093 (U.S.A. and Canada)
Business Hours: 6:00 a.m. - 5:00 p.m. Pacific Time

Contact us through our web site at:

www.Dacor.com

You may also write us at:

Dacor Customer Service
1440 Bridge Gate Drive
Diamond Bar, CA 91765

At Dacor, we believe that our quality of service equals that of our product. Should your experience with our service network or product be different, please contact our Customer Service Team and share your encounter with us. We will do our utmost to resolve the situation for you and deliver on our Dacor promise.

If you need anything clarified, just let us know.

Warranty

What Is Covered

CERTIFICATE OF WARRANTIES: DACOR DISHWASHERS

WITHIN THE FIFTY STATES OF THE U.S.A., THE DISTRICT OF COLUMBIA, AND CANADA*:

FULL ONE-YEAR WARRANTY

If your DACOR product fails to function within one year of the original date of purchase, due to a defect in material or workmanship, DACOR will remedy the defect without charge to you or subsequent users. The owner must provide proof of purchase upon request and have the appliance accessible for service.

FULL TWENTY-FIVE YEAR WARRANTY

On rust-through of stainless steel tank and door.

Warranty is null and void if non-CUL approved product is transported from the U.S.A.

OUTSIDE THE FIFTY STATES OF THE U.S.A., THE DISTRICT OF COLUMBIA, AND CANADA:

LIMITED FIRST YEAR WARRANTY

If your DACOR product fails to function within one year of the original date of purchase, due to a defect in material or workmanship, DACOR will furnish a new part, F.O.B. factory, to replace the defective part. All delivery, installation, and labor costs are the responsibility of the purchaser. The owner must provide proof of purchase, upon request, and have the appliance accessible for service.

What Is Not Covered

- Service calls to educate the customer in the proper use and care of the product.
- Failure of the product when used for commercial, business, rental or any application other than for residential consumer use.
- Replacement of house fuses or fuse boxes, or resetting of circuit breakers.
- Damage to the product caused by accident, fire, flood or other acts of God.
- Breakage, discoloration or damage to glass, metal surfaces, plastic components, trim, paint or other cosmetic finish, caused by improper usage or care, abuse, or neglect.

THE REMEDIES PROVIDED FOR IN THE ABOVE EXPRESS WARRANTIES ARE THE SOLE AND EXCLUSIVE REMEDIES. THEREFORE, NO OTHER EXPRESS WARRANTIES ARE MADE, AND OUTSIDE THE FIFTY STATES OF THE UNITED STATES, THE DISTRICT OF COLUMBIA, AND CANADA, ALL IMPLIED WARRANTIES, INCLUDING BUT NOT LIMITED TO, ANY IMPLIED WARRANTY OF MERCHANTABILITY OR FITNESS FOR A PARTICULAR USE OR PURPOSE, ARE LIMITED IN DURATION TO ONE YEAR FROM THE DATE OF ORIGINAL PURCHASE. IN NO EVENT SHALL DACOR BE LIABLE FOR INCIDENTAL EXPENSE OR CONSEQUENTIAL DAMAGES. NO WARRANTIES, EXPRESS OR IMPLIED, ARE MADE TO ANY BUYER FOR RESALE.

Some states do not allow limitations on how long an implied warranty lasts, or do not allow the exclusion or limitation of inconsequential damages, so the above limitations or exclusions may not apply to you. This warranty gives you specific legal rights, and you may also have other rights that vary from state to state.

Notes

Notes

Notes

fold here

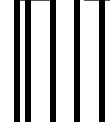

NO POSTAGE
NECESSARY
IF MAILED
IN THE
UNITED STATES

BUSINESS REPLY MAIL
FIRST-CLASS MAIL PERMIT NO. 4507 DIAMOND BAR CA

POSTAGE WILL BE PAID BY ADDRESSEE

DACOR INC.
ATTN: WARRANTY PROCESSING DEPT
1440 BRIDGE GATE DR STE 200
PO BOX 6532
DIAMOND BAR CA 91765-9861

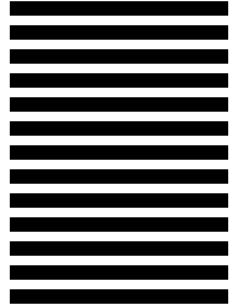



Please visit www.Dacor.com to activate your warranty online.

WARRANTY INFORMATION



IMPORTANT:

Your warranty will not be activated until you activate it online or return this form to Dacor. If you have purchased more than one Dacor product, please return all forms in one envelope or activate the warranty for each product online.

Please rest assured that under no conditions will Dacor sell your name or any of the information on this form for mailing list purposes. We are very grateful that you have chosen Dacor products for your home and do not consider the sale of such information to be a proper way of expressing our gratitude!

Owner's Name: _____
Last (Please Print or Type) First Middle

Street: _____

City: _____ State: _____ Zip: _____

Purchase Date: _____ Email: _____ Telephone: _____

Dealer: _____

City: _____ State: _____ Zip: _____

Your willingness to take a few seconds to fill in the section below will be sincerely appreciated. Thank you.

1. How were you **first** exposed to Dacor products? (Please check one only.)

- A. T.V. Cooking Show
- B. Magazine
- C. Appliance Dealer Showroom
- D. Kitchen Dealer Showroom
- E. Home Show
- F. Builder
- G. Architect/Designer
- H. Another Dacor Owner
- I. Model Home
- J. Other _____

2. Where did you buy your Dacor appliances?

- A. Appliance Dealer
- B. Kitchen Dealer
- C. Builder Supplier
- D. Builder
- E. Other _____

3. For what purpose was the product purchased?

- A. Replacement **only**
- B. Part of a Remodel
- C. New Home
- D. Other _____

4. What is your household income?

- A. Under \$75,000
- B. \$75,000 – \$100,000
- C. \$100,000 – \$150,000
- D. \$150,000 – \$200,000
- E. \$200,000 – \$250,000
- F. Over \$250,000

5. What other brands of appliances do you have in your kitchen?

- A. Cooktop _____
- B. Oven _____
- C. Dishwasher _____
- D. Refrigerator _____

6. Would you buy or recommend another Dacor product?

- Yes
- No

Comments: _____

Thank you very much for your assistance. The information you have provided will be extremely valuable in helping us plan for the future and giving you the support you deserve.

cut here

cut here