

# COMBINATION INSTALLATIONS



## RGC/SGM Series Drop-In Gas Cooktop with RV Series Raised Vent

## PLANNING GUIDE

### Cutout Dimensions

All tolerances +1/16" -0 (+1.6 mm, 0) unless otherwise noted

**IMPORTANT:** Be careful to use the correct cutout diagram (on page 2/2) to determine the countertop dimensions. Carefully double check all dimensions against the table below and the correct diagram before cutting the countertop.

Countertop Dimensions							
Installation Type	Cutout Diagram	C (Min.)	D	E	F	G	H
RGC/SGM304 with RV30	Figure 1 (Square)	5/8" (16 mm)	22 1/4" * (565 mm)	27 3/4" (686 mm)	NA	NA	NA
RGC/SGM365 with RV36	Figure 1 (Square)	5/8" (16 mm)	22 1/4" * (565 mm)	33 5/8" (854 mm)	NA	NA	NA
SGM466 with RV46	Figure 2 (Notched)	5/8" (16 mm)	22 1/4" * (565 mm)	44 3/4" (1137 mm)	43 1/2" (1105 mm)	5/8" (16 mm)	2 5/8" ** (67 mm)

\* Total cutout depth, accommodates both the cooktop and raised vent

\*\* **IMPORTANT:** Notch depth is included in total cutout depth (D). **DO NOT** add notch depth to total cutout depth (D).



### WARNING

- ◇ Observe all governing codes and ordinances during planning and installation. Contact your local building department for further information.
- ◇ All appliances must be installed in accordance with the accompanying installation instructions.

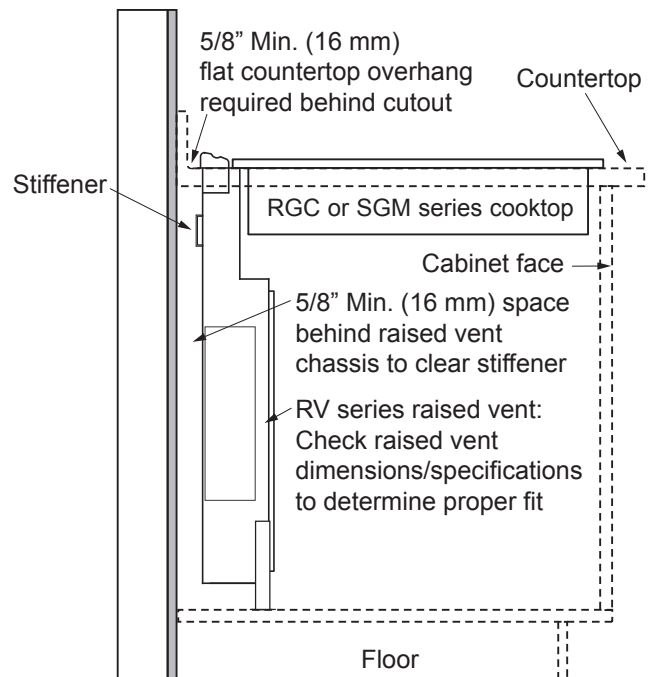

Side View - RGC/SGM Series Cooktop with RV Series Raised Vent

# COMBINATION INSTALLATIONS



## RGC/SGM Series Drop-In Gas Cooktop with RV Series Raised Vent

## PLANNING GUIDE

All tolerances: +1/16", -0, (+1.6mm, -0) unless otherwise stated

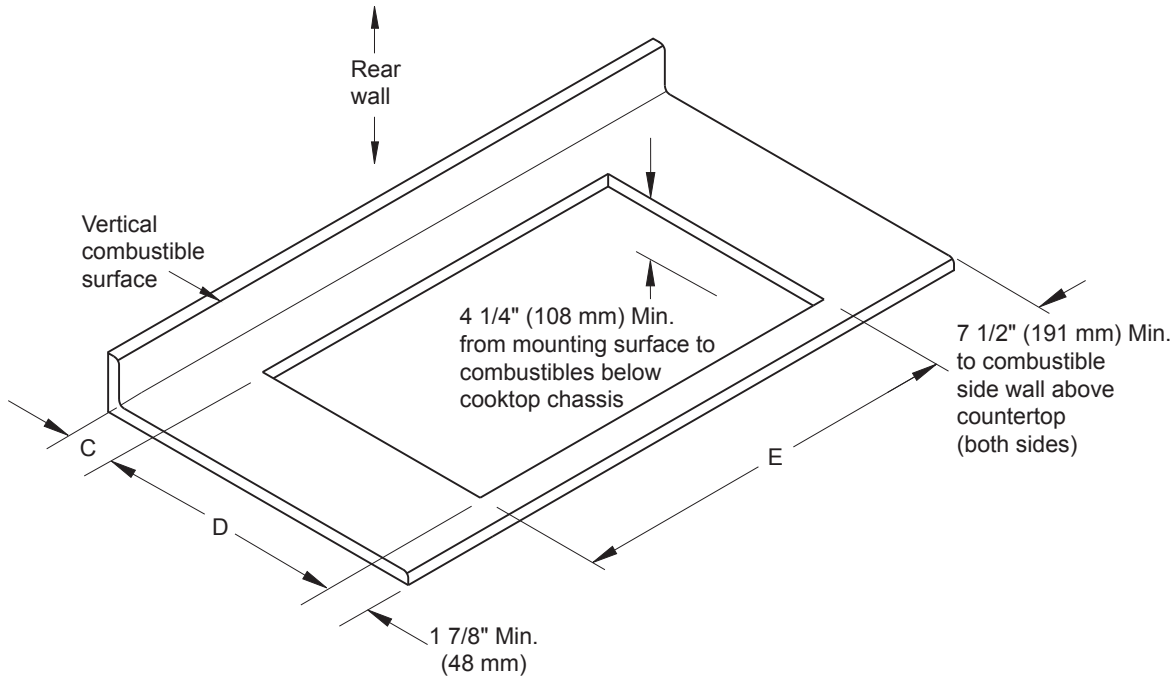

Figure 1 - Square Countertop Cutout Diagram

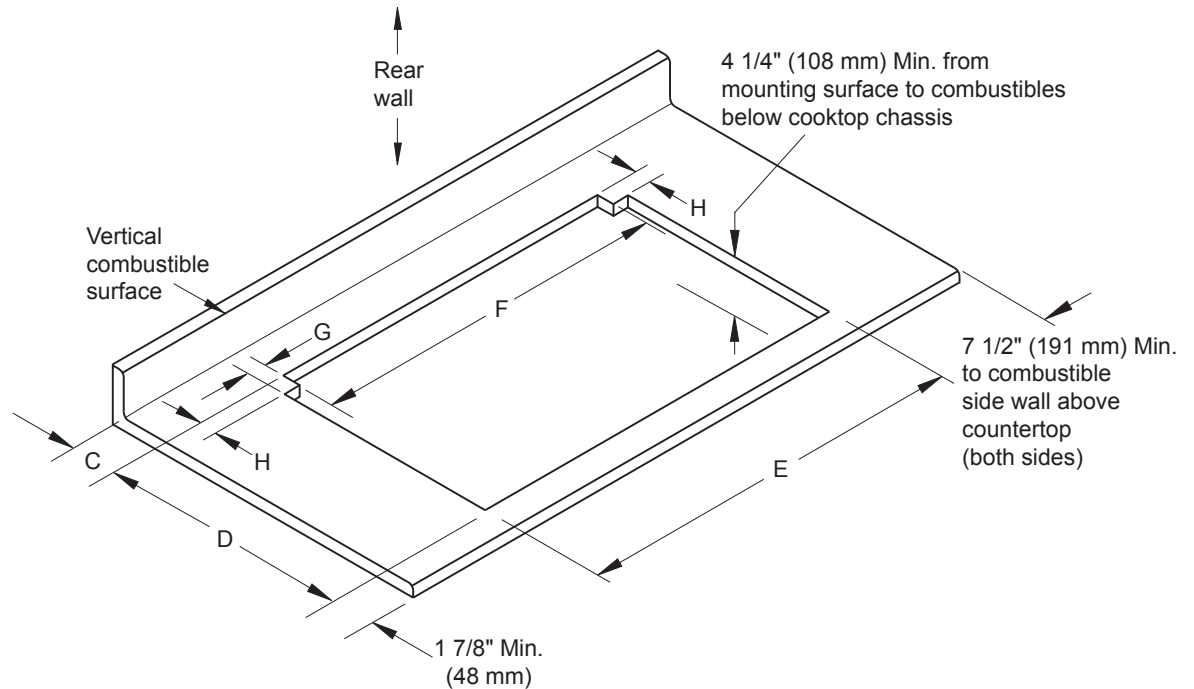

Figure 2 - Notched Countertop Cutout Diagram  
(SGM466 only)