

Installation
Operation
and
Maintenance
Instructions

Refrigerated
Beverage Center
3BARM & 6BARM



life. luxury. marvel.

An AGA Company

UNPACKING YOUR BEVERAGE CENTER

Remove Packaging

Your beverage center has been packed for shipment with all parts that could be damaged by movement securely fastened. Before using, be sure all packing materials and tape have been removed.

Important

Keep your carton packaging until your beverage center has been thoroughly inspected and found to be in good condition. If there is damage, the packaging will be needed as proof of damage in transit.

Note to Customer

This merchandise was carefully packed and thoroughly inspected before leaving our plant. Responsibility for its safe delivery was assumed by the retailer upon acceptance of the shipment. Claims for loss or damage sustained in transit must be made on the retailer as follows:

- Exterior and Concealed Damage
Any damage must be reported immediately your retailer.

DO NOT RETURN DAMAGED MERCHANDISE TO THE MANUFACTURER - FILE THE CLAIM WITH THE RETAILER.

REMINDER

IT IS IMPORTANT THAT YOU SEND IN YOUR WARRANTY RECORD CARD IMMEDIATELY AFTER TAKING DELIVERY OF YOUR BEVERAGE CENTER.

Model	Exterior Cabinet Dimensions (in.)			Finished Cut-Out Opening Dimensions (in.)			Weight (lbs.)	Temperature Range (°F)	Power Supply (supplied with a 15 amp plug)
	H	W	D	H	W	D			
3BARM	34 1/4	14 7/8	23 5/8	34 1/2	15	24	100	40-65	115VAC/60Hz
6BARM	34	23 7/8	24 1/4	34 1/2	24	24	130	40-65	115VAC/60Hz

INSTALLING YOUR BEVERAGE CENTER

Select Location

The proper location will ensure peak performance of your appliance. Choose a location where the unit will be out of direct sunlight and away from heat sources. Best performance will be maintained when installed within the following parameters:

Ideal Ambient Temperature Range	
Built-In	65-80 °F
Free-Standing	65-90 °F

Cabinet Clearance

Ventilation is required from the bottom front section of the unit. Keep this area open and clear of any obstructions.

Leveling Legs

Adjustable legs at the front corners of the unit should be set so the unit is firmly positioned on the floor and the front is raised just enough so that the door closes easily when opened about halfway.

Turn leveling legs clockwise to raise unit, counterclockwise to lower it.

Door Hinge Reversing

You can change the door swing from right- to left-hand very easily. Simply unscrew the top and bottom hinge pin, lift the door off the bottom hinge, and switch the hinges to the other side. Screw the hinge pin back in what is now the bottom hinge, unscrew the hinge pin in what is now the top hinge, replace door, and screw the pin back in the top hinge.

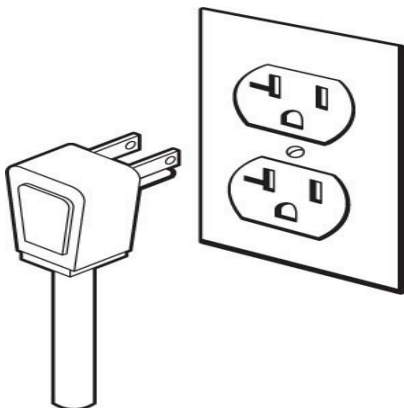

Figure 1

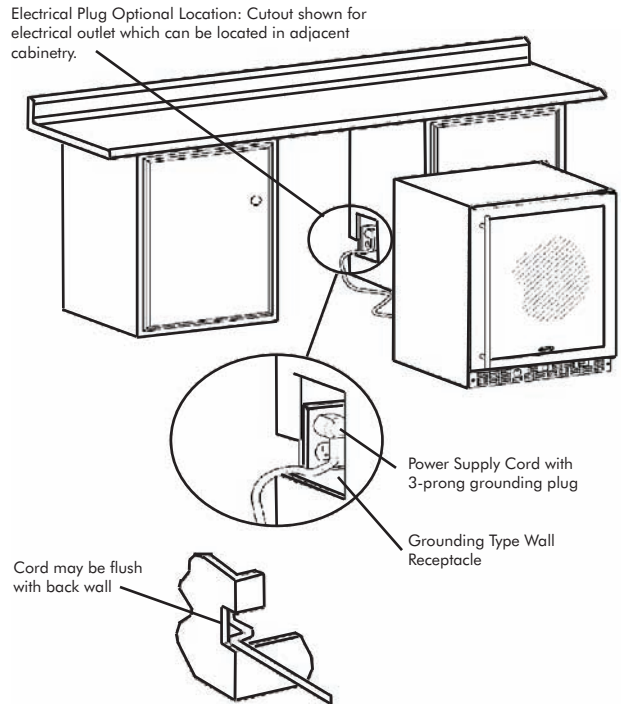

Figure 2

Electrical Connection

Use nominal 115 VAC, 60 Hz only. **DO NOT USE AN EXTENSION CORD.**

Grounding Method

This product is factory equipped with a power supply cord that has a three-pronged, grounded plug. It must be plugged into a mating grounding type receptacle in accordance with the National Electrical Code and applicable local codes and ordinances (see Figure 1). If the circuit does not have a grounding type receptacle, it is the responsibility and obligation of the customer to exchange the existing receptacle in accordance with the National Electrical Code and applicable local codes and ordinances. The third ground prong should not, under any circumstances, be cut or removed (see Figure 2). All U.L. listed refrigerated products are equipped with this type of plug.

MICROSENTRY™ REFRIGERATION MONITOR

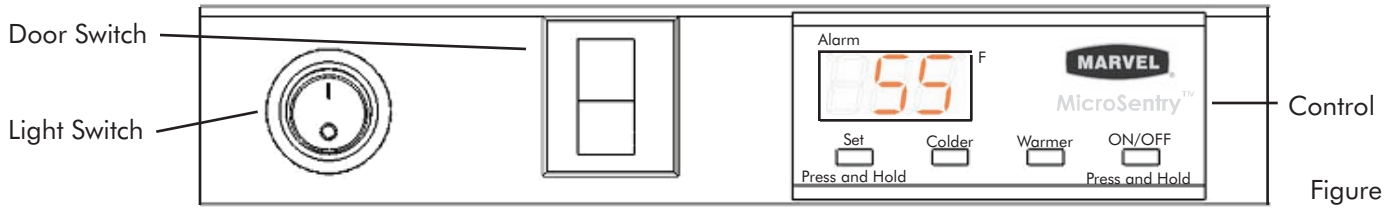

Figure 3

Start Your Appliance

To start your appliance, plug it into a power supply. Push and hold the "ON/OFF" button located on the display panel for three (3) seconds (see Figure 3).

NOTE: The unit may take 5 to 10 minutes to start.

Once the bottles are loaded, allow at least 48 hours for the unit to stabilize before making any adjustments to the initial setting.

Set the Controls

The available temperature range of the unit is from 40 to 65 degrees F. The middle range on the control is approximately 55 degrees F. The temperature can be lowered or raised by first pushing and holding the "SET" button for one (1) second on the display pad. You will enter Temperature SET MODE. Pushing either the "WARMER" or "COLDER" key while holding the "SET" key will raise or lower the set temperature by one (1) degree F. Releasing the "SET" key exits SET MODE. As with any refrigeration product, there is a slight temperature variance at different locations within the cabinet.

Adjustable Temperature Control

The temperature control is fully adjustable from the low forties to the mid sixties. The range allows flexibility of temperature preferences.

Interior Light and Switch

The interior light makes it easy to view your wine labels and enhances the display of your collection. To engage the display light feature, press the round light switch. It is located on the left side of the user panel. The light will come on and stay on with the door closed until the light switch is pressed again. The light will also come on when the door is opened.

Information/Lockout Key

Each momentary press of the "SET" key activates the Information and Lockout selection menu. Additional presses sequentially scroll through the Information selection menu and allow the enabling and disabling of the Lockout feature.

• Information Selection Menu

1. **Current Interior Temperature (tl):** Press and hold the "SET" key to display the current interior temperature.
2. **Maximum Stored Temperature (thi):** Press and hold the "SET" key to display the maximum temperature stored. The data can be cleared by pressing "SET" and "ON/OFF" simultaneously while the value is displayed.
3. **Minimum Stored Temperature (tLO):** Press and hold the "SET" key to display the minimum temperature stored. The data can be cleared by pressing "SET" and "ON/OFF" simultaneously while the value is displayed.
4. **Total Operating Time of the Condenser Since the Last Cleaning (cnd):** Press and hold the "SET" key to display the total operating hours of the compressor since the last cleaning. The control stores the total operating hours of the compressor to determine the volume of air that has moved across the condenser coils. This number is displayed in weeks. A reminder is displayed when a cleaning is recommended (see Alarm Codes). The recommended cleaning period is the equivalent of one year of air volume. The data can be cleared by pressing the "SET" and "ON/OFF" keys simultaneously while the value is displayed.
5. **Keypad Lockout Feature (Loc):** This feature is useful for prohibiting changes in the temperature set point or accidentally turning the unit off. Press and hold the "SET" key to display the current "Loc" setting. If "No" is displayed, Lockout is OFF and all keys are enabled. If "Yes" is displayed, Lockout is ON and the "ON/OFF", "WARMER", and "COLDER" keys are disabled. However, the key tones remain enabled. While holding the "SET" key, press the "WARMER" or "COLDER" key to select the desired state. Release the "SET" key to confirm the selection.

NOTE: The Information/Lockout Key "SET" remains enabled regardless of the "Loc" setting.

MICROSENTRY™ REFRIGERATION MONITOR

Warning Alarms

Your beverage center has been fitted with a **MicroSentry™** refrigeration monitor. This monitor will let you know if your cellar is not functioning properly for optimum wine and beverage storage.

Door Ajar Alarm

If the door has been left open for over five (5) minutes, the alarm will sound in one (1) second intervals. The display panel will flash "Do" and the LED light will be a steady amber color. This will stop as soon as the door is closed.

High and Low Temperature

If your unit reaches an unacceptable temperature outside of your set point for more than one (1) hour, the alarm will sound in one (1) second intervals. The display panel will flash either "Hi" or "Lo" depending upon the condition and the LED light will be a steady amber color. "Hi" indicates that the temperature is 10 degrees F above the set point and "Lo" indicates that the temperature is 10 degrees F below the set point. These alarms will warn you that your wines have seen temperatures that may not be conducive for long term storage. The alarm will remain active until the condition is corrected.

NOTE: During initial appliance start-up, the high temperature alarm may sound until the interior temperature reaches set point.

Alarm Codes

The control monitors and stores select unit parameters and will display error codes with sound each time a fault is detected. See reference below for a description of each error code.

Error Code Detection Reference	
Error Code	Description
Do	Door Open
Hi	High Temperature
Lo	Low Temperature
E1	Sensor Fault
CL	Condenser Coil Cleaning Recommended

Audible Alarm Mute

Press any key to mute the audible portion of an alarm condition. Alarm sound is only muted, not disabled. If the condition(s) that caused the alarm(s) continue, visual indication will continue and alarm sound will periodically continue for 20 seconds every 60 minutes.

3BARM BEVERAGE CENTER FEATURES

Insert Wine Bottles

The wine rack pull-out shelf holds four (4) bottles. See Figure 4 for typical wine bottle orientation. The wine rack can be located at the middle or bottom part of the interior cabinet. For red wines, place wine shelf at bottom shelf position in the cabinet. Then put a glass shelf in the next higher position. For white and sparkling wines, put the wine shelf on the middle shelf position in the cabinet. Place the remaining shelves as desired (see Figure 5).

Loading Tips and Suggestions

The glass shelves and fixed position wire rack are for general beverage storage, such as beer and soft drinks. Opened wine bottles and tall beverage containers may be stored on the glass shelf closest to the cabinet top. Just lift the hinged section of the fixed position upper wire rack to provide clearance for the bottles and/or containers to stand upright.

You may store magnums and other large bottles on any of the racks (except for the top rack) by removing the rack directly above them. Position white wines on the middle or lower racks and red wines on the upper racks (see Figure 6).

The bottles on the top rack directly under the light will be exposed to a slightly higher temperature when the light is on. Position your wines accordingly and **REMEMBER TO TURN OFF THE LIGHT WHEN IT IS NO LONGER NEEDED.**

Keep wines that you plan to use for everyday drinking and entertaining on the front half of the racks where labels are completely visible. Place wines for aging or longer term storing in the rear.

Pull-out Racks

The pull-out wine rack may be pulled out approximately seven (7) inches to facilitate adding or removing bottles. Do NOT lean on or press down heavily on the wine shelf. Doing so may damage the shelf and the wine bottles stored on it. Pull the wine rack out gently and carefully to minimize unsettling your wine collection. AVOID pulling out more than one rack at any time to maintain stability.

Single Bottle Racks

Since bottles are not stacked on top of each other, you can easily view and access your inventory without disturbing other bottles (see Figure 6).

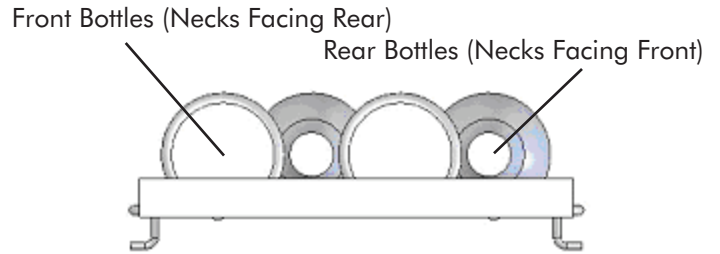

Figure 4

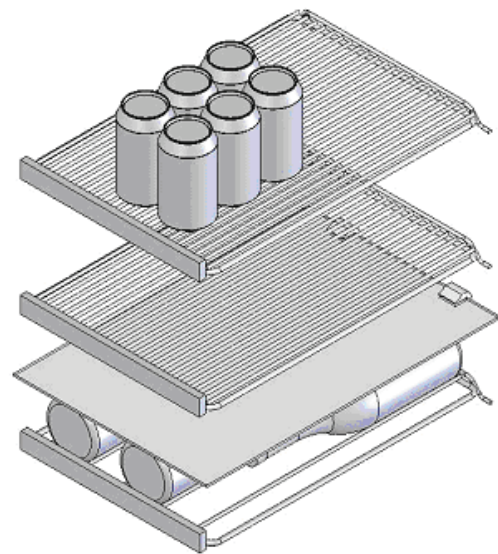

Figure 5

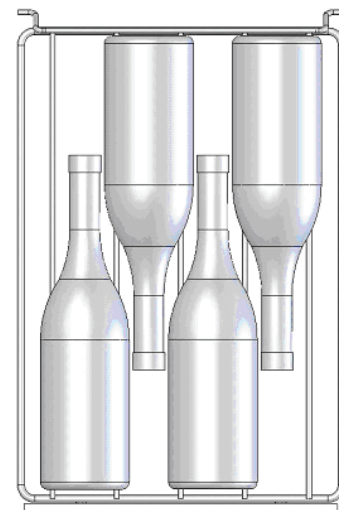

Figure 6

6BARM BEVERAGE CENTER FEATURES

Insert Wine Bottles

The wine rack pull-out shelf holds eight (8) bottles. See Figure 7 for typical wine bottle orientation. The wine rack can be located at the middle or bottom part of the interior cabinet. For red wines, place wine shelf at bottom shelf position in the cabinet. Then put a glass shelf in the next higher position. For white and sparkling wines, put the wine shelf on the middle shelf position in the cabinet. Place the remaining shelves as desired (see Figure 8). Also, there is a fixed, wooden, bottle cradle in the bottom, step section of the cabinet. Six (6) bottles may be stored there.

Loading Tips and Suggestions

The glass shelves and fixed position wire rack are for general beverage storage, such as beer and soft drinks. Opened wine bottles and tall beverage containers may be stored on the glass shelf closest to the cabinet top. Just lift the hinged section of the fixed position upper wire rack to provide clearance for the bottles and/or containers to stand upright.

The wooden, bottom bottle cradle may be removed for storing "jug" wines. Just remove the two (2) screws that secure the cradle to the cabinet floor.

You may store magnums and other large bottles on any of the racks (except for the top rack) by removing the rack directly above them. Position white wines on the middle or lower racks and red wines on the upper racks (see Figure 9).

The bottles on the top rack directly under the light will be exposed to a slightly higher temperature when the light is on. Position your wines accordingly and **REMEMBER TO TURN OFF THE LIGHT WHEN IT IS NO LONGER NEEDED.**

Keep wines that you plan to use for everyday drinking and entertaining on the front half of the racks where labels are completely visible. Place wines for aging or longer term storing in the rear.

Pull-out Racks

The pull-out wine rack may be pulled out approximately seven and a half (7.5) inches to facilitate adding or removing bottles. Do NOT lean on or press down heavily on the wine shelf. Doing so may damage the shelf and the wine bottles stored on it. Pull the wine rack out gently and carefully to minimize unsettling your wine collection. AVOID pulling out more than one rack at any time to maintain stability.

Single Bottle Racks

Since bottles are not stacked on top of each other, you can easily view and access your inventory without disturbing other bottles (see Figure 9).

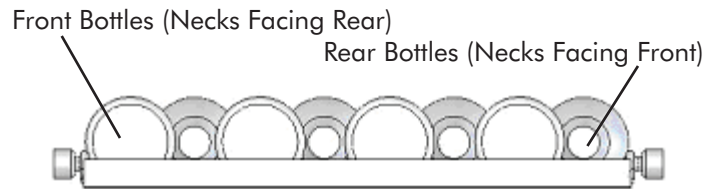

Figure 7

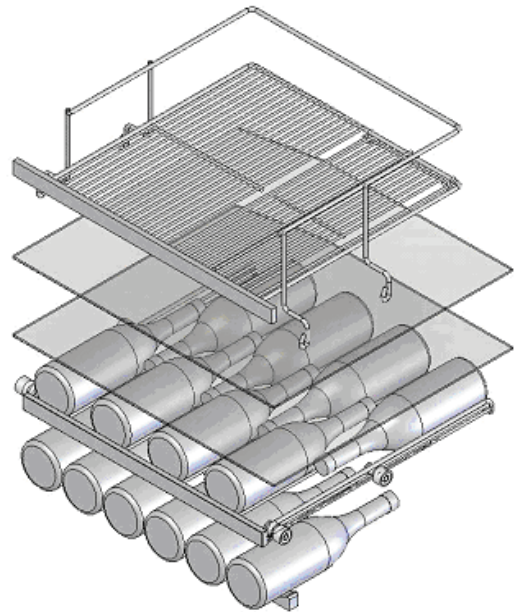

Figure 8

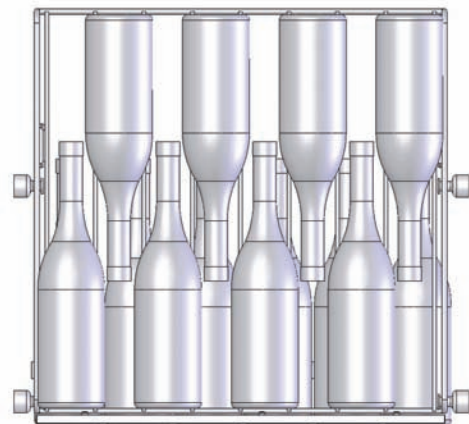

Figure 9

CARE AND CLEANING OF YOUR BEVERAGE CENTER

Condenser

The condenser tubing inside the cabinet does not require frequent cleaning; however, satisfactory cooling depends on adequate ventilation over the coils. Be sure that nothing obstructs the required air flow openings in front of the cabinet. At least once or twice a year, brush or vacuum lint and dirt from the condenser for efficient performance by unscrewing the grille on the bottom front of the cabinet.

Cabinet

The painted cabinet can be washed with mild soap and water and thoroughly rinsed with clear water. NEVER use abrasive scouring cleaners.

Interior

Wash interior compartment with mild soap and water. Do NOT use an abrasive cleaner, solvent, polish cleaner or undiluted detergent.

Pull-out/Wire Racks

The racks may be cleaned with mild soap and water and a soft cloth. Do NOT use any abrasive cleaners.

Glass Shelves

Use a glass cleaner or mild soap and water and soft cloth to clean the glass shelves. Do NOT use any abrasive cleaners.

Glass Door

Use a glass cleaner or mild soap and water and soft cloth to clean the glass door model. Do NOT use any abrasive cleaners.

Door Gasket

The vinyl gasket may be cleaned with mild soap and water, a baking soda solution or a mild scouring powder.

Light Bulb Replacement

WARNING! DISCONNECT THE POWER CORD BEFORE ATTEMPTING LIGHT BULB REPLACEMENT. Failure to do so may result in an electrical shock that could severely injure you.

The 3BARM and 6BARM use one, 15 watt incandescent light bulb to illuminate the interior of the beverage center. The light bulb is a very reliable electrical component, but should it not function properly, please call the dealer where you purchased your beverage center from for a replacement light bulb. Use only an original equipment light bulb from your dealer or Marvel Industries.

Do NOT under any circumstance use a light bulb that exceeds 15 watts!

To replace the light bulb, disconnect power to the unit. Unscrew the old light bulb located behind the display housing at the top of the unit. Set the old light bulb aside. Screw the new light bulb into place. Reconnect the power to the unit. Check to see if the light bulb operates properly to complete the installation.

The light bulb is not covered by your warranty. A replacement bulb can be obtained from your dealer or from Marvel Industries.

In the Event of a Power Failure

If a power failure occurs, try to correct it as soon as possible. Minimize the number of door openings while the power is off so as not to adversely affect the unit's temperature.

NOTE: If a power interruption occurs, the unit may take 5 to 10 minutes to restart.

TROUBLESHOOTING YOUR BEVERAGE CENTER

Before Calling for Service

Before calling for service, check the troubleshooting table on this page. This table lists possible problems that you can remedy without difficulty to avoid an unnecessary service call.

PROBLEM	POSSIBLE CAUSES/SOLUTIONS
Odor in cabinet	1. Interior needs cleaning
Noisy operation	1. Cabinet not level
	2. Weak floor
Cabinet vibrates	1. Cabinet not level
	2. Weak floor
Cabinet light not working	1. Tube burned out
	2. No power at outlet
Appliance will not run	1. "ON/OFF" button pressed
	2. Power cord not plugged in
	3. No power at electrical outlet
	4. House fuse blown
Appliance runs too long	1. Prolonged door openings
	2. Control set too cold
	3. Condenser needs cleaning
Moisture collects inside	1. Too many door openings
	2. Prolonged door openings
	3. Hot, humid weather increases condensation
	4. Control improperly set
Moisture collects on outside surface	1. Hot, humid weather increases condensation (as humidity decreases, moisture will disappear)
	2. Control improperly set
Interior too hot/too cold	1. Control improperly set

Help Prevent Tragedies

Each year children die because they climb inside a discarded refrigeration product, get trapped inside and suffocate. Take precautions to prevent such tragedies by removing the door or by taping or chaining it shut before discarding.

OBTAINING SERVICE FOR YOUR BEVERAGE CENTER

If You Do Need Service

If you do need service, contact your dealer or Marvel Industries. In any correspondence, refer to the model number and serial number of your unit which is located on the upper left hand side of the wall liner. Retain your proof of purchase. You may want to record these numbers in the space below.

For Your Records	
Date of Purchase	
Dealer's Name	
Dealer's Address	
Dealer's City	
Dealer's State	
Dealer's Zip	
Appliance Serial Number	
Model Number	
Date Warranty Card Sent (Must be within 10 Days of Purchase)	

How to Obtain Service

Your refrigerated beverage center requires little service because the best and most up to date materials, equipment and quality methods are employed throughout the manufacturing process.

If trouble occurs during normal operation, first check the troubleshooting chart on the previous page to see if any of these simple steps may correct the problem. If service becomes necessary:

1. If the product is within the first year warranty period, please call Marvel Customer Service at 800.428.6644 for directions on how to obtain warranty coverage in your area.
2. If the product is outside of the first year warranty period, Marvel Customer Service can provide recommendations of service centers in your area. A listing of authorized service centers is also available at www.lifeluxurymarvel.com under the Service and Support section.
3. In all correspondence regarding service, be sure to give the model number, serial number, and proof of purchase.
4. Try to have information or description of the nature of the problem, how long the unit has been running, the room temperature, and any additional information that may be helpful in quickly solving the problem.

HOUSEHOLD PRODUCT WARRANTY

Entire Product

Limited One Year Parts and Labor Warranty

Marvel warrants that it will supply all necessary parts and labor to repair or replace in the end user's home or office, any component which proves to be defective in material or workmanship, subject to the condition and exclusions stated below, for a period of one year from the date of purchase by the end user.

Additional Second Through Fifth Year

Limited Parts Only Warranty

During the four years following expiration of the one year limited warranty, Marvel will supply replacement parts for the hermetically sealed refrigeration system which consists of the compressor, condenser, drier, accumulator, bypass valve, connecting tubing and the evaporator that are proven to be defective due to workmanship or materials subject to the conditions and exclusions below.

The above warranties do not cover:

- Shipping costs of replacement parts or returned defective parts.
- Customer education or instructions on how to use the appliance.
- Any content loss due to product failure.
- Removal or installation.

Nor do the above warranties cover failure of this product or its components due to:

- Transportation or subsequent damages.
- Use commercially or use other than normal household or small office.
- Improper installation, misuse, abuse, accident or alteration, use on wiring not conforming to electrical codes, low or high voltages, failure to provide necessary maintenance, or other unreasonable use.

Parts or Service

Not Supplied or Designated by Marvel

The above warranties also do not apply if:

- The original bill of sale, deliver date, or serial number cannot be verified.
- Defective parts are not returned for inspection if so requested by Marvel.
- The refrigeration equipment is not in the possession of the original end use purchaser.

The warranties set forth herein are the only warranties extended by Marvel Industries. Any implied warranties, including the implied warranty of merchantability, are limited to the duration of these express warranties. In no event shall Marvel Industries be liable for any consequential or incidental damages or expenses resulting from breach of these or any other warranties, whether express or implied.

Some states do not allow the exclusion or limitation of consequential damages or a limitation on how long an implied warranty lasts, so the above exclusion or limitation may not apply to you. This warranty gives you specific legal rights and you may have other rights that may vary from state to state.

No person, firm, or corporation is authorized to make any other warranty or assume any other obligation for Marvel Industries. These warranties apply only to products used in any of the fifty states of the United States and the District of Columbia.

To obtain performance of this warranty, report any defects to:

Marvel Industries
P.O. Box 997
Richmond, Indiana 47375-0997
Phone: 800.428.6644



Marvel Industries
P.O. Box 997
Richmond, IN
47375-0997

800.428.6644

An AGA Company

41010735 Rev. E
03.03.08

www.lifeluxurymarvel.com

All specifications and product designs subject to change without notice. Such revisions do not entitle the buyer to corresponding changes, improvements, additions, replacements or compensation for previously purchased products.