

Viking Use & Care Manual

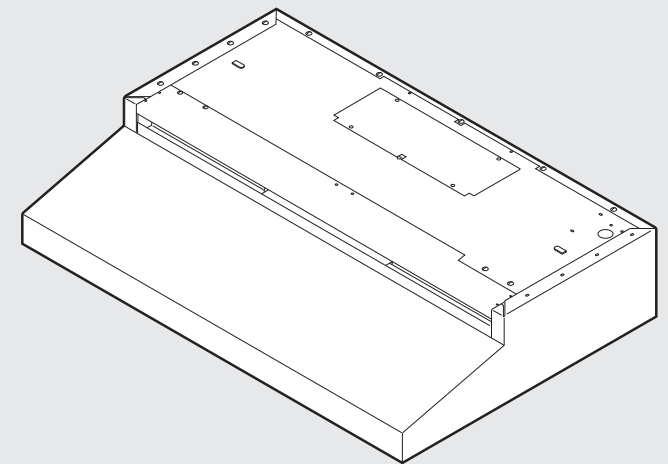

Viking Range Corporation
111 Front Street
Greenwood, Mississippi 38930 USA
(662) 455-1200

For product information,
call 1-888-VIKING1 (845-4641)
or visit the Viking Web site at
vikingrange.com



6"H. Wall Hood

Congratulations

Your purchase of a Viking hood attests to the importance you place upon the quality and performance of the major appliances you use. With minimal care, as outlined in this manual, your new hood is designed to provide you with years of reliable service. Please take a few minutes to learn about its proper and efficient use and care.

This manual will provide you with the information you need to become familiar with your hood's care and operation.

Your complete satisfaction is our ultimate goal. If you have any questions or comments about this product, please contact the dealer from whom you purchased it, or contact our Consumer Support Center at 1-888-VIKING1.

We appreciate your choosing a Viking Range Corporation product, and hope that you will again select our products for your other major appliance needs.

For more information about the complete and growing selection of Viking products, contact your dealer or visit us online at vikingrange.com.

Table of Contents

Getting Started

Warnings and Important Safety Information _____	4
Before Using the Hood _____	8
Features _____	8

Product Controls

Settings and Functions _____	9
------------------------------	---

Product Care

Cleaning and Maintenance _____	10
Service Information _____	13
Warranty _____	14

IMPORTANT—Please Read and Follow

Warning and Important Safety Instructions appearing in this manual are not meant to cover all possible conditions and situations that may occur. Common sense, caution, and care must be exercised when installing, maintaining, or operating this appliance.

ALWAYS contact the manufacturer about problems or conditions you do not understand.

Recognize Safety Symbols, Words, Labels

DANGER

Hazards or unsafe practices which **WILL** result in severe personal injury or death

WARNING

Hazards or unsafe practices which **COULD** result in death or severe personal injury

CAUTION

Hazards or unsafe practices which **COULD** result in minor personal injury or property damage.

All safety messages will identify the hazard, tell you how to reduce the chance of injury, and tell you what can happen if the instructions are not followed.

IMPORTANT—Please Read and Follow

WARNING

To reduce the risk of fire, electric shock, or injury when using your unit, observe the following:

- Installation work and electrical wiring must be done by qualified person(s) in accordance with all applicable codes and standards, including fire-rated construction.
- Sufficient air is needed for proper combustion and exhausting of gases through the flue (chimney) of fuel burning equipment to prevent back drafting. Follow the heating equipment manufacturer's guideline and safety standards such as those published by the National Fire Protection Association (NFPA), and the American Society for Heating, Refrigeration and Air Conditioning Engineers (ASHRAE), and the local code authorities.
- When cutting or drilling into wall or ceiling, **DO NOT** damage electrical wiring and other hidden utilities.
- Ducted fans must always be vented to the outdoors.
- **WARNING!** To reduce the risk of fire, use only metal ductwork.
- **CAUTION!** To reduce risk of fire and to properly exhaust air, be sure to duct air outside. **DO NOT** vent exhaust air into spaces within walls or ceilings, or into attics, crawl spaces, or garages.

WARNING

To reduce the risk of fire, electric shock, or injury to persons, observe the following:

- Use this unit only in the manner for which it is intended. If you have any questions, contact the manufacturer.
- Before servicing or cleaning unit, switch power off at service panel and lock service panel to prevent power from being switched on accidentally. When the service disconnecting means cannot be locked, securely fasten a prominent warning device, such as a tag, to the service panel.

IMPORTANT—Please Read and Follow

⚠ WARNING

To reduce the risk of a rangetop grease fire:

- **NEVER** leave surface units unattended at high settings. Boil-overs cause smoking and greasy spillovers that may ignite. Heat oils slowly on low or medium settings.
- **ALWAYS** turn hood ON when cooking at high heat or when cooking flaming foods.
- Clean ventilating fans frequently. Grease should not be allowed to accumulate on fan or filters.
- Use proper pan size. **ALWAYS** use cookware appropriate for the size of the cooking area.

⚠ WARNING



To reduce the risk of injury to persons in the event of a rangetop grease fire, observe the following: (Based on "Kitchen Firesafety Tips," published by NFPA.)

1. **SMOTHER FLAMES** with a close fitted lid, cookie sheet, or metal tray, then turn off the burner. **BE CAREFUL TO PREVENT BURNS.** If the flames do not go out immediately, **EVACUATE AND CALL THE FIRE DEPARTMENT.**
2. **NEVER PICK UP A FLAMING PAN.** You may be burned.
3. **DO NOT USE WATER,** including wet dishcloths or towels a violent steam explosion will result.
4. Use an extinguisher **ONLY** if
 - You know it is a Class ABC extinguisher, and you already know how to operate it.
 - The fire is small and contained in the area where it started.
 - The fire department is being called.
 - You can fight the fire with your back to an exit.

⚠ WARNING

To reduce the risk of fire, electrical shock, or injury to persons, rangehoods must be installed with the ventilators that are specified on their carton indicating suitability with this model. Other ventilators cannot be substituted.

IMPORTANT—Please Read and Follow

⚠ CAUTION

For general ventilating use only. **DO NOT** use to exhaust hazardous or explosive materials and vapors.

⚠ CAUTION

If the power to the hood is not disconnected during cleaning, the heat sensor thermostat can cause the blower to turn on.

⚠ CAUTION

Unplug power cords from control panel before cleaning or servicing hood.

⚠ CAUTION

DO NOT place flammable material on warming shelves when using heat lamps.

⚠ CAUTION

All brass special ordered parts are coated with an epoxy coating. **DO NOT** use brass cleaners or abrasive cleansers on the brass option parts.

⚠ CAUTION

DO NOT use a porcelain cleaner or rough abrasive cleaner.

Before Using the Hood

Although the hood is cleaned upon completion of the manufacturing process, you will probably need to clean your hood again after installation. Wipe the surface of the hood with a good household cleaner applied with a soft cloth, or stainless steel polish, depending on the finish of your hood. This will leave a protective finish on the hood.

Features

Heat Sensor Thermostat

Your hood is equipped with a heat sensor thermostat. The thermostat will turn on or speed up the blower if it senses excessive heat above the cooking surface. When the sensor activates, the letters "HOT" will appear on the display. If the blower is OFF—the sensor turns the blower on to HIGH speed. If the blower is on at a lower speed setting—the sensor turns the blower up to HIGH speed. When the temperature level drops to normal, the blower will return to its original setting and the display will be cleared.

CAUTION

If the power to the hood is not disconnected during cleaning, the heat sensor thermostat can cause the blower to turn on.

Settings and Functions

Hood Operation

ALWAYS turn on your hood before you begin cooking to establish airflow in the kitchen. Also, let the blower run for a few minutes to clear the air after you turn off your cooking appliance. This will help keep the kitchen air cleaner.

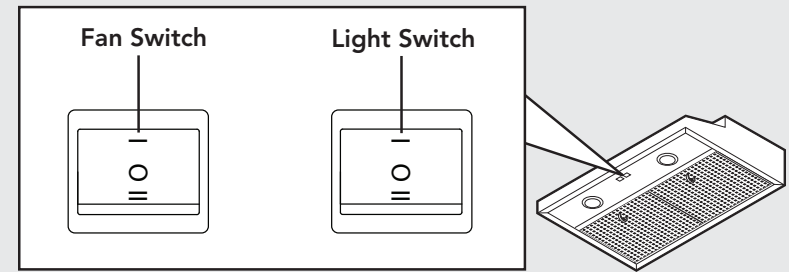

Fan switch—Starts and stops the blower. Position I (—) Low speed and Position II (≡) High speed.

Light switch—Controls the 50-watt halogen lights located in the front of the hood. Position I (—) Low setting and Position II (≡) High setting.

Cleaning and Maintenance

⚠ CAUTION

Unplug power cords from control panel before cleaning or servicing hoods.

Any piece of equipment works better and lasts longer when maintained properly and kept clean. Ventilation equipment is no exception. Your hood must be kept clean and maintained properly.

Cleaning Mesh Filters

As air passes through the filter, grease particles collect on the stainless steel screen inside the filter. The filters should be examined periodically to assure that all surfaces and parts are clean. This unit is equipped with an alarm. Once the unit has been in operation for 48 hours, the letters "FILT" will appear on the display. The filters can then be washed in a dishwasher or in a sink with hot, soapy water. Simple periodic cleaning will ensure maximum effectiveness. **DO NOT** use caustic detergent to clean the filters. An abrasive or corrosive cleaner may damage the finish. **DO NOT** take the filters apart to clean them. It is not necessary and will void the filter warranty. Once the filters have been cleaned and placed back in the hood, the display is canceled by holding the scroll up (+) and the scroll down (-) buttons for 5 seconds.

⚠ CAUTION

For general ventilating use only. **DO NOT** use to exhaust hazardous or explosive materials and vapors.

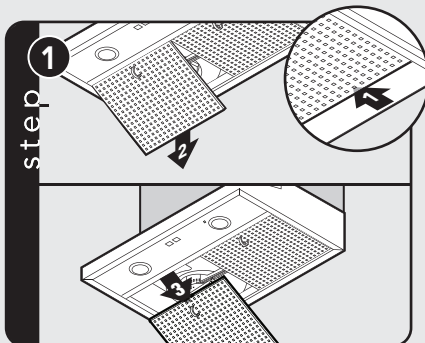

Slide filter front over front lip. Push filter rear up, then slide back over rear lip.

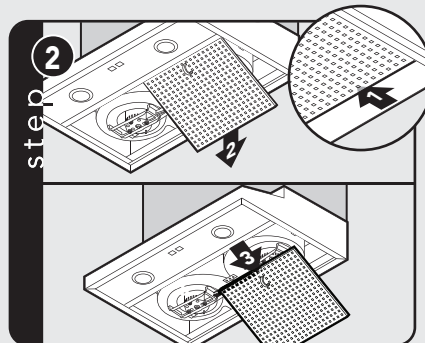

Slide filter front over front lip. Push filter rear up, then slide back over rear lip.

Cleaning and Maintenance

Maintaining Charcoal Filter (Recirculating Hoods Only)

Replace the charcoal filters every 6 months to 1 year depending on the amount and type of cooking you do.

To replace, remove the baffle/charcoal filter assembly and slide the charcoal filter out of the channel and replace with a new one. **DO NOT** put the charcoal filters in the dishwasher.

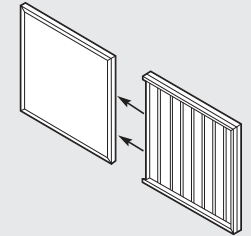

Replacement filters are available through your local Viking Range dealer, or you can call the Viking Online Store at 1-877-834-8222 or visit vikingrange.com

Cleaning Hood Canopy

Finishes in enamel or stainless steel are highly resistant to damage or discoloration due to grease, steam, and heat—provided that reasonable care is given to the equipment. The following suggestions will help keep your hood looking new.

1. **DO NOT** allow an excessive accumulation of grease. For best results, you should wipe your hood clean with a cloth dipped in warm, soapy water. **DO NOT USE ABRASIVE CLEANSERS, STEEL WOOL PADS, OR ABRASIVE CLOTHS.** **DO NOT** use cleansers that contain chlorides; the chlorides in the cleaner could damage the stainless steel finish. If you need to scrape stainless steel to remove encrusted materials, first soak the area with hot towels to loosen the material, then use a wooden or nylon spatula or scraper. **DO NOT** use a metal knife, spatula, or any other metal tool to scrape stainless steel.
2. Every 3 months give your hood a thorough cleaning. On painted surfaces, use a new coat of wax. A good wax cleaner—available at either a grocery or hardware store—will do both jobs at once. On stainless steel surfaces, use a good stainless steel cleaner and polish.

Cleaning and Maintenance

Renewing Enamel Finish

If discoloration occurs, you should thoroughly polish the finish on your hood to renew its gloss and luster and to remove any grease residue which may have a yellowing effect. Use any good enamel polish, refrigerator polish, or automotive polish.

⚠ CAUTION

DO NOT use a porcelain cleaner or rough abrasive cleaner.

Renewing Stainless Steel Finish

Regular cleaning is the best way to assure that your stainless steel finish stays bright and unscratched. Use lemon oil or stainless steel polish to coat and protect stainless steel.

⚠ CAUTION

All brass special ordered parts are coated with an epoxy coating. **DO NOT** use brass cleaners or abrasive cleansers on the brass option parts.

Replacing the Light Bulbs

When removing bulbs, use an oven mitt to protect your hand in case the bulb breaks.

Halogen Lights

1. Unscrew halogen bulb.
2. Replace the bulb with a 120 volt, 50-watt halogen bulb.

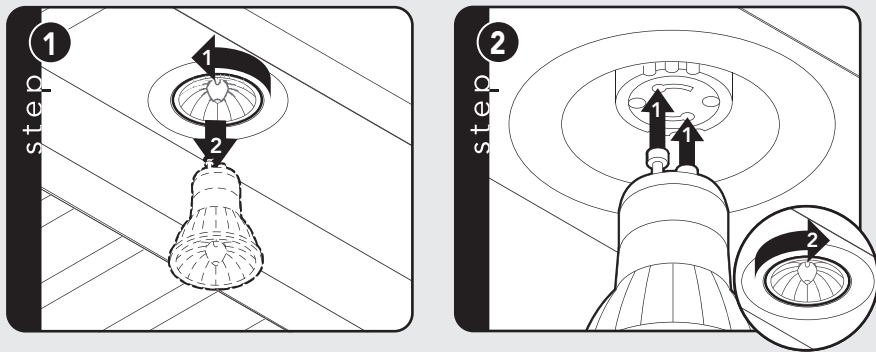

Service Information

If service is required, call your dealer or authorized service agency. The name of the authorized service agency can be obtained from the dealer or distributor in your area.

Have the following information readily available.

- Model number
- Serial number
- Date purchased
- Name of dealer from whom purchased

Clearly describe the problem that you are having. If you are unable to obtain the name of an authorized service agency, or if you continue to have service problems, contact Viking Range Corporation at 1-888-VIKING1 (845-4641), or write to:

**VIKING RANGE CORPORATION
PREFERRED SERVICE
1803 Hwy 82W
Greenwood, Mississippi 38930 USA**

Record the information indicated below. You will need it if service is ever required. The model and serial number for your hood is located behind the baffle filter on the left side panel in the lower right corner.

Model no. _____ Serial no. _____

Date of purchase _____ Date installed _____

Dealer's name _____

Address _____

If service requires installation of parts, use only authorized parts to insure protection under the warranty.

Keep this manual for future reference.

Warranty

6" H. WALL HOOD WARRANTY

ONE YEAR FULL WARRANTY

Built-in hoods/ventilators and all of their component parts, except as detailed below*, are warranted to be free from defective materials or workmanship in normal household use for a period of twelve (12) months from the date of purchase. **NOTE:** Viking Range ventilator kits are designed specifically for use with Viking Range hoods. Use of any non-Viking Range ventilator kits **VOIDS** the hood warranty. Viking Range Corporation, warrantor, agrees to repair or replace, at its option, any part which fails or is found to be defective during the warranty period.

*Glass (including light bulbs), painted, and decorative items are warranted to be free from defective materials or workmanship for a period of ninety (90) days from the date of original retail purchase. ANY DEFECTS MUST BE REPORTED TO THE SELLING DEALER WITHIN NINETY (90) DAYS FROM DATE OF ORIGINAL RETAIL PURCHASE.

Viking Range Corporation uses the most up-to-date processes and best materials available to produce all color finishes. However, slight color variation may be noticed because of the inherent differences in painted parts and porcelain parts as well as differences in kitchen lighting, product locations, and other factors.

FIVE YEAR LIMITED WARRANTY

Any hood blower motor which fails due to defective materials or workmanship in normal household use during the second year through the fifth year from the date of original retail purchase will be repaired or replaced, free of charge for the part itself, with the owner paying all other costs, including labor.

This warranty extends to the original purchaser of the product warranted hereunder and to each transferee owner of the product during the term of warranty.

This warranty shall apply to products purchased and located in the United States and Canada. Products must be purchased in the country where service is requested. Warranty labor shall be performed by an authorized Viking Range Corporation service agency or representative. Warranty shall not apply to damage resulting from abuse, accident, natural disaster, loss of electrical power to the product by anyone other than an authorized Viking Range Corporation service agency or representative. This warranty does not apply to commercial usage. Warrantor is not responsible for consequential or incidental damage whether arising out of breach of warranty, breach of contract, or otherwise. Some jurisdictions DO NOT allow the exclusion or limitation of incidental or consequential damages, so the above limitation or exclusion may not apply to you.

Owner shall be responsible for proper installation, providing normal care and maintenance, providing proof of purchase upon request, and making the appliance reasonably accessible for service. If the product or one of its component parts contains a defect or malfunction during the warranty period, after a reasonable number of attempts by the warrantor to remedy the defects or malfunctions, the owner is entitled to either a refund or replacement of the product or its component part or parts. Replacement of a component part includes its free installation. Warrantor's liability on any claim of any kind, with respect to the goods or services covered hereunder, shall in no case exceed the price of the goods or service or part thereof which gives rise to the claim.

WARRANTY SERVICE

Under the terms of this warranty, service must be performed by a factory authorized Viking Range Corporation service agent or representative. Service will be provided during normal business hours, and labor performed at overtime or premium rates shall not be covered by this warranty. To obtain warranty service, contact the dealer from whom the product was purchased, an authorized Viking Range Corporation service agency, or Viking Range Corporation. Provide model and service number and date of original purchase. For the name of your nearest authorized Viking Range Corporation service agency, call the dealer from whom the product was purchased or Viking Range Corporation. **IMPORTANT:** Retain proof of original purchase to establish warranty period.

The return of the Owner Registration Card is not a condition of warranty coverage. You, however, should return the Owner Registration Card so that Viking Range Corporation can contact you should any question of safety arise which could affect you.

Any implied warranties of merchantability and fitness applicable to the above described hood or ventilator motors are limited in duration to the period of coverage of the applicable express written limited warranties set forth above. Some jurisdictions do not allow limitations on how long an implied warranty lasts, so the above limitation may not apply to you. This warranty gives you specific legal rights, and you may also have other rights which may vary from jurisdiction to jurisdiction.

Specifications subject to change without notice.