

PT956BM/CM/WM

GE Profile™ 30" Built-In Double Convection/Thermal Wall Oven

Dimensions and Installation Information (in inches)

KW Rating	
240V	9.0
208V	6.8
Breaker Size	
240V	40 Amps
208V	40 Amps

Note: Cabinets installed adjacent to wall ovens must have an adhesion spec of at least a 194°F temperature rating. **Electric wall ovens are not approved for installation with a plug and receptacle. They must be hard wired in accordance with installation instructions.**

Door handle protrudes 3" from door face. Cabinets and drawers on adjacent 45° and 90° walls should be placed to avoid interference with the handle.

Installation Information: Before installing, consult installation instructions packed with product for current dimensional data.

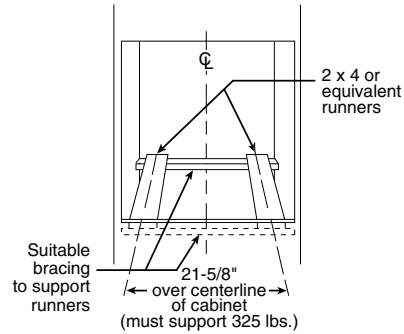

Cabinet	30"
A – Overlap of oven over side of edges of cutout	11/16"-3/4"
B – Overlap of oven at top and bottom of cutout	1"
Oven	
C – Overall depth*	23-1/2"
D – Overall height with trim	53-3/8"
Overall height without trim	52-7/8"
E – Overall width	29-3/4"

*Depth including door handle is approximately 26-6/10" min. to 26-9/10" max.

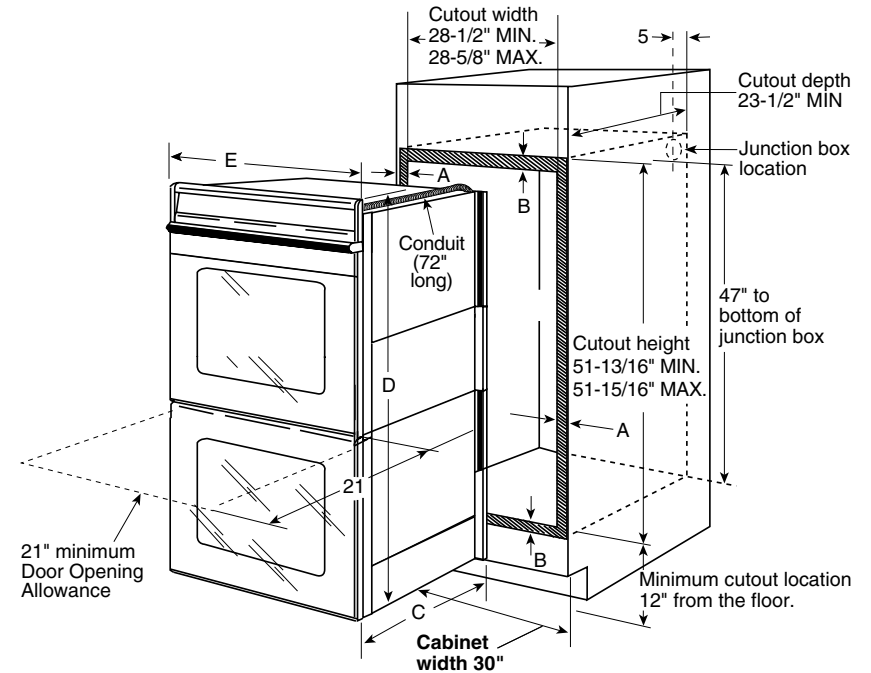

MOST 30" WALL CABINETS CAN BE USED WITH THIS UNIT.
THE OPENING BETWEEN THE INSIDE WALLS MUST BE AT LEAST 28-1/2" WIDE.

For answers to your Monogram®, GE Profile™ or GE® appliance questions, visit our website at ge.com or call GE Answer Center® service, 800.626.2000.



Specification Created 1/07

220139

PT956BM/CM/WM

GE Profile™ 30" Built-In Double Convection/Thermal Wall Oven

Features and Benefits

- Glass Touch Controls - Features a smooth glass design that is easy-to-operate and easy-to-clean
- Precise Air™ Convection System (Upper Oven Only) - Provides even air and heat circulation for superior baking and roasting results
- Flat Back Convection (Upper Oven Only) - Features a more streamline convection fan that better accommodates baking or roasting pans
- Convection Bake (Upper Oven Only) - Delivers ideal airflow throughout the oven cavity, ensuring better baking results
- Convection Roast (Upper Oven Only) - Delivers even cooking and consistent results, roasting meats up to 25% faster than a conventional oven
- Hidden Bake Oven Interior - Hides previously exposed bottom element to deliver a clean interior appearance
- Self Clean Oven - Conveniently cleans the oven cavity without need of scrubbing
- Improved Lighting - Positions lamps diagonally across the top of the oven to promote better viewing
- Self-Clean Heavy-Duty Oven Racks - Double coated porcelain-enameled racks no longer require hand cleaning
- Extra-Large Oven Capacity - Provides a large oven interior ideal for cooking more items at once
- Model PT956BMBB – Black on black
- Model PT956CMCC – Bisque on bisque
- Model PT956WMWW – White on white

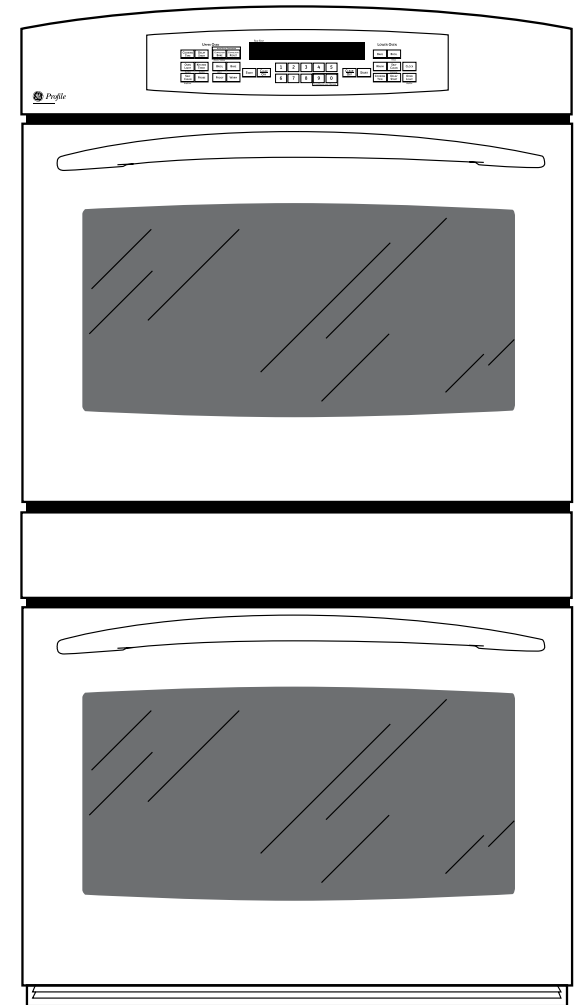

imagination at work

Specification Created 1/07

220139