



Echelon Series



Installation Guide

2175WC Wine Captain® and 2175WCOL2 Wine Captain® with Overlay

www.U-LineService.com

Phone (414) 354-0300 • FAX (414) 354-7905
Service & Parts Tech Lines Phone (800) 779-2547 • FAX (414) 354-5696
OnlineService@U-Line.com

©2008 U-Line Corporation
03/2008

Contents

1-Follow Safety Precautions 2

2-Inspect and Plan 3

 Exterior Cleaning 4

3-Prepare Site 4

 Cut-Out Dimensions 4

 Product Dimensions 5

 Door Swing/Clearances Information 5

 Other Site Requirements 5

 Side-By-Side Installation Instructions 6

4-Prepare Racks and Door Frame 6

 Wine Rack Removal/Installation 6

 Wood Trim Finishing 7

 Reversing the Door 8

 Overlay Frame 9

 Frame Preparation 9

 Prepare the New Overlay Panel 10

 Attaching the Overlay Panel 10

 Assembling Door to Cabinet 11

5-Adjust Door 12

 Checking Door Alignment 12

 Adjusting Door Alignment 12

6-Prepare Power Supply 13

 Electrical Specifications 13

7-Level the Unit 13

 Leveling Information 13

 Installation Tip 13

8-Install the Unit 14

 Anti-Tip Bracket Installation 14

 Single Unit Installation 15

 Side-by-Side Installation 15

 Installation Troubleshooting 15

9-Start-Up for the First Time 15

 Initial Start-Up 15

 Start-Up Troubleshooting 15

Who to Call 16

 Service Information 16

1 Follow Safety Precautions

IMPORTANT

PLEASE READ all instructions completely before attempting to install or operate the unit.

- This unit requires connection to a grounded (three-prong), polarized receptacle that has been placed by a qualified electrician in accordance with applicable electrical codes.

Safety Alert Definitions

Safety items throughout this guide are labeled with a Danger, Warning or Caution based on the risk type:

⚠ DANGER

Danger means that failure to follow this safety statement will result in severe personal injury or death.

⚠ WARNING

Warning means that failure to follow this safety statement could result in serious personal injury, or death.

⚠ CAUTION

Caution means that failure to follow this safety statement may result in minor or moderate personal injury, property or equipment damage.

General Precautions

Use this appliance for its intended purpose only and follow these general precautions along with those listed throughout this guide:

⚠ WARNING

SHOCK HAZARD — Electrical Grounding Required.

- **Keep the unit unplugged throughout installation except during testing.**
- **Never remove the round grounding prong from the plug and never use a two-prong grounding adapter.**
- **Never use an extension cord to connect power to the unit.**
- **Always keep your working area dry.**

⚠ CAUTION

- Use care when moving and handling the unit. Use gloves to prevent personal injury from sharp edges.
- Do not lift the unit by the door or door handle.
- Do not install the unit behind closed doors or in any way that would obstruct airflow to the front grille, which may cause the unit to malfunction.

2 Inspect and Plan

You have received a carton containing your 2175WC or 2175WCOL2 Wine Captain® with a package inside containing a Use and Care Guide, a Product Registration Card and an Anti-Tip Bracket Installation Kit. 2175WCOL2 units are shipped with an additional package of hardware. Complete and mail the Product Registration Card or register online at www.U-LineService.com. Once your unit is installed, keep the Use and Care Guide and this Installation Guide in a safe place for future reference.

2175WC units are Black or Stainless Steel. Black units have a reversible door with a slightly contoured handle across the top. Stainless Steel units are covered with a protective coating and have been ordered left- or right-hand hinged. The Stainless doors are not reversible.

2175WCOL2 units are Black with a door that requires the construction of a 3/4-inch thick wood overlay frame. You must determine left- or right-hand opening before construction.

All units come with maple trim wine racks that can be finished or stained. Please carefully follow the directions that apply to your unit and your intended design.

Tools/Materials Required

- Screwdrivers — slotted and Phillips head
- Sandpaper; low odor, water clean up, quick drying finish; tack cloth and, if desired, water-based wood stain and synthetic foam brush
- 3/4-inch overlay frame material, cutting tools, drill and bits (2175WCOL2 units)

Inspection

Unwrap and inspect the unit on a flat, level surface capable of supporting its entire weight.

Removing Protective Coating

(Stainless Steel Units Only)

When inspecting/installing a Stainless Steel unit, the protective coating covering the unit must be removed first. Start at a corner of the unit/door and pull back the protective coating to remove it from the unit/door.

After all the protective coating has been removed from the unit/door, clean all Stainless Steel surfaces with Claire Stainless Steel Polish and Cleaner or comparable product or a mild detergent and warm water solution and soft cloth. Do NOT use abrasive cleaning agents.

Note: If cleaning with mild detergent and warm water solution and soft cloth, the unit MUST be treated with Claire Stainless Steel Polish and Cleaner or comparable product to prevent discoloration.

Exterior Cleaning

(As Required)

Black Models:

- The door, grille and cabinet may be cleaned with a mild detergent and warm water solution. Do not use solvent-based or abrasive cleaners. Use a soft sponge and rinse with clean water. Wipe with a soft, clean towel to prevent water spotting.

Stainless Steel Models:

- Stainless steel models can discolor when exposed to chlorine gas, pool chemicals, salt water or cleaners with bleach.
- Keep your stainless steel unit looking new by cleaning with a good quality all-in-one stainless steel cleaner/polish on a monthly basis. For best results use Claire Stainless Steel Polish and Cleaner, which can be purchased from U-Line Corporation. (The part number is 173348.) Comparable products are acceptable. Frequent cleaning will remove surface contamination that could lead to rust. Some installations may require cleaning on a weekly basis.
- **Do not clean with steel wool pads.**
- **Do not use cleaners that are not specifically intended for stainless steel (this includes glass, tile and counter cleaners).**
- If any surface discolors or rusting appears, clean it quickly with Bon-Ami or Barkeepers Friend Cleanser and a non-abrasive cloth. Always clean in the direction of the grain. Always finish this process with Claire Stainless Steel Polish and Cleaner or comparable product to prevent further problems.
- **Use of abrasive pads such as Scotchbrite will cause the graining in the stainless to become blurred.**
- Rust that is allowed to linger can penetrate into the surface of the stainless steel and complete removal of the rust may not be possible.

3 Prepare Site

Your U-Line product has been designed for either free-standing or built-in installation. When built-in, your unit does not require additional air space for top, sides or rear. However, the front grille must NOT be obstructed and clearance is required for electrical connection in the rear.

Note: Unit can NOT be installed behind a closed cabinet door.

Cut-Out Dimensions

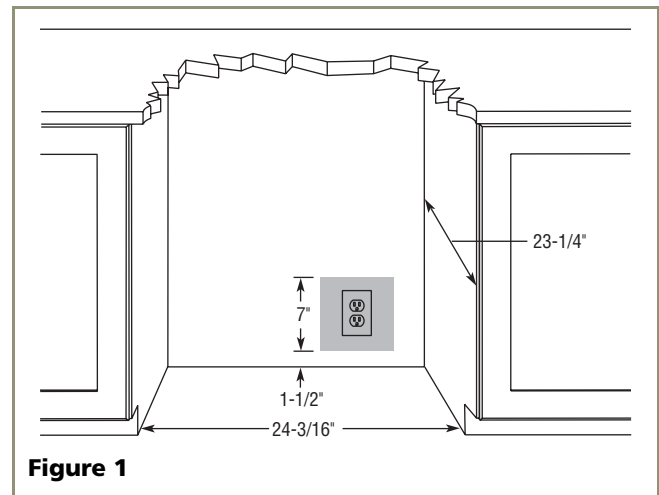

Figure 1

Follow the cut-out drawing in **Figure 1**. The 24-3/16" width allows 1/4" for ease in installation and removal of the unit. 24" is the cabinet depth in most installations. The unit is 23-1/4" deep including the handle on Black 2175WC models, 23-1/4" deep including the wood overlay frame on 2175WCOL2 models and 23-1/4" deep including the door and *not* the handle on Stainless Steel models (see **Figure 2**).

Product Dimensions

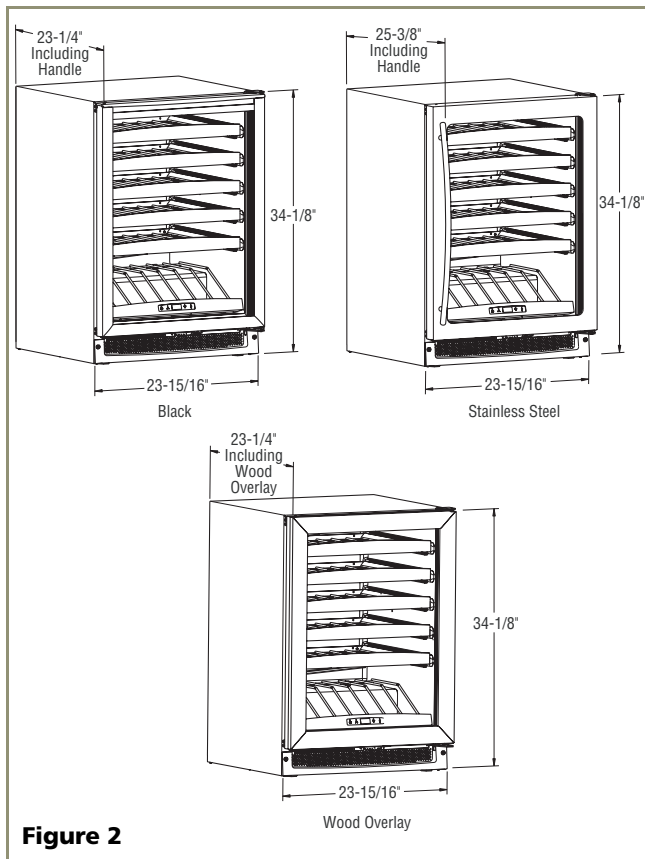

Figure 2

Please note that the unit has adjustable feet that can add one additional inch to height during leveling or to match adjacent cabinets (see **Figure 26** on **Page 13**).

Door Swing/Clearances Information

Black and Wood Overlay units have a zero clearance for the door to open 90° (see **Figure 3**). Stainless Steel models require a minimum of 2-1/8" door clearance to accommodate the handle if the unit is installed next to a wall or similar type of structure.

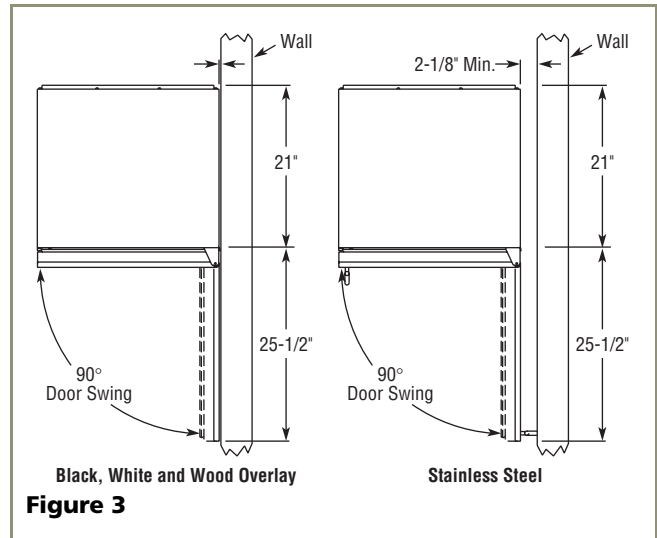

Figure 3

Other Site Requirements

Power Supply

The unit requires a grounded and polarized 115 VAC, 60 Hz, 15A circuit (normal household current). See *Electrical Specifications* on **Page 13**.

Environmental Requirements

Many U-Line models are designed to operate in harsh outdoor/marine environments. Special considerations include the following:

- The units are designed to operate between 50°F (10°C) and 110°F (40°C). High ambient temperatures (110°F [40°C] or higher) may reduce the unit's ability to reach low temperatures.
- For best performance, keep the unit out of direct sunlight and away from heat generating equipment.
- In climates where high humidity and dew points are present, condensation may appear on outside surfaces. This is considered normal. The condensation will disappear when the humidity drops.
- U-Line does not recommend installation of glass front models (Wine Captain® wine storage models and Beverage Centers) as well as the Combo Drawer model (Refrigerator/Freezer/Ice Maker) outdoors, or in tropical climates where high humidity and dew point are present on a regular basis, unless air-conditioning (typical 72°F, 75%RH) will be used.

Side-By-Side Installation Instructions

For a complete refreshment center, install your 2175WC or 2175WCOL2 unit beside a U-Line Refrigerator, Ice Maker or Combo Model (see **Figure 4** for typical cut-out). Note that each Side-By-Side Installation will be different.

- Cut-out width for a side-by-side installation is the total of the widths listed under *Cut-Out Dimensions* in each unit's Installation Guide.

For example:

Placing a 2175 Wine Captain® next to a 2115 series unit would require a cut-out width of:
 $24\text{-}3/16" + 15\text{-}3/16" = 39\text{-}3/8"$

Placing a 2175 Wine Captain® next to a 2175 series unit would require a cut-out width of:
 $24\text{-}3/16" + 24\text{-}3/16" = 48\text{-}3/8"$

- No trim kit is required. However, 1/4-inch space needs to be maintained between the units to ensure unobstructed door swing.
- Units must operate from separate, properly grounded electrical receptacles placed according to each unit's *Electrical Specifications*.

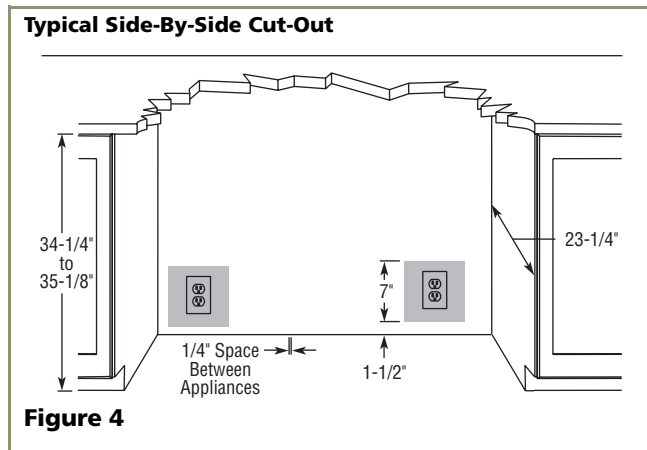

Figure 4

4 Prepare Racks and Door Frame

The U-Line Wine Captain® is equipped with wood-trimmed wine racks that are coated at the factory with a clear vinyl sealer, which will adequately protect the wood in normal usage. A final finish coat was not applied so that the wood trim could be stained to match décor or overlay frame. The trim on the racks may be coated with a final finish or stained.

2175WCOL2 Models are designed for, and require installation of, an Overlay Frame.

If none of these treatments are to be included in this installation, go on to **5 Adjust Door**.

CAUTION

To prevent permanent damage to the inner liner of the Wine Captain®, the wine rack wood trim **MUST** be removed from the unit for staining and/or finishing. Allow stain/finish to dry thoroughly (at least 24 hours per coat) in accordance with the stain/finish manufacturer's instructions prior to re-installing the wood trim inside the cabinet of the Wine Captain®. Failure to do so may cause the inner liner of the unit to have a permanent odor, which is not covered by the warranty.

Wine Rack Removal/Installation

To remove a rack from the cabinet:

1. Grasp the end of the rack, and gently slide it out until it stops.
2. Remove any bottles stored on the rack.

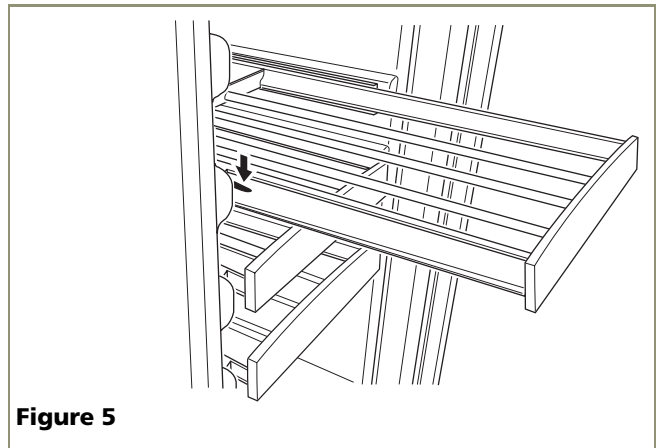

Figure 5

3. Press the left rack release lever (**Figure 5**) down, and at the same time, lift the corresponding right rack release lever up, and pull the rack out until it is free of the tracks and the cabinet.

IMPORTANT

Do not remove the track side rails from the cabinet.

To insert a rack in the cabinet:

1. Align the left and right rack channels with the tracks in the cabinet, and ensuring an even track engagement on both sides, gently push the rack into the cabinet until it stops.
2. Before reloading the rack, ensure proper operation of the travel stops in the left and right track rails by pulling the rack out gently until it completely stops.

Wood Trim Finishing

Interior components of your U-Line unit are equipped with a natural wood trim for appearance and durability. Although this wood trim has been coated with a clear sealer at the factory, it is recommended that the trim be stained (if desired), and receive a final finish coating prior to the unit going into full-time service.

WARNING

To prevent permanent damage to the inner liner of your unit, the wood trim MUST be removed from the unit for staining and/or finishing. Allow stain/finish to dry thoroughly (at least 24 hours per coat) in accordance with the product manufacturer's instructions prior to reinstallation. Failure to do so may cause the inner liner of the unit to have a permanent odor, which is not covered by the warranty.

If staining the trim is desired, it must be done before the application of any type of final finish. Review the following staining/final finish and final finish-only guidelines when staining/ and or sealing the wood to ensure proper adhesion and durability of the finish.

NOTE: Glass in door is tinted. Stain may look darker when door is closed.

Staining and final finish application:

1. Remove all screws securing wood trim to interior components, and remove the trim from the cabinet interior.

NOTE: Your model will contain an electronic display panel in the lowest level trim piece. After removing the trim screws, and gently pulling the trim from its location, a wiring harness connector will become visible. Unplug the connector, and remove the trim from the interior.

IMPORTANT

DO NOT use oil-based stains on wood trim. Vapors from oil-based stains will permanently penetrate the liner and will not dissipate over time.

2. Apply Minwax® Water-Based Wood Stain to wood with a synthetic bristle brush or a foam applicator. Allow stain to penetrate approximately three minutes. Before the stain is dry, take a stain dampened rag and remove any excess stain remaining. Wipe in the direction of the grain with medium pressure to achieve the desired stain color.
3. After two hours, repeat step 2. This will even out the color of the wood.
4. Allow stain to dry for a minimum of three hours before applying the final finish.
5. If desired, sand the wood with very fine sandpaper to smooth the surface after the staining process.
6. Remove all dust from the wood, and apply one coat of Minwax® Polycrylic® Protective Finish using a synthetic bristle brush to the wood. This finish should be applied in a thin coat following the direction of the grain. Apply the finish to the back and sides of the wood first, and allow it to dry for two hours. Apply the finish to the front side of the wood next, and allow it to dry for two hours. Sand with very fine 220 grit sandpaper. Apply two additional coats of the finish in the same manner, but do not sand the trim after the final third coat is applied.
7. Allow the final coat to dry for 24 hours before reinstalling the trim to the cabinet interior components.

Final finish-only application:

1. Remove all screws securing wood trim to interior components, and remove the trim.
2. Lightly scuff sand the wood trim with 280 or finer grit sandpaper.
3. Remove sanding dust with a clean, dry cloth.
4. The factory-applied seal is compatible with virtually all finishes. A low odor, water clean up, quick-drying finish such as Minwax® Polycrylic® Protective Finish is recommended (Minwax® Polycrylic® is an ultra fast-drying water-based finish). Apply a thin coat of a clear, protective finish, following the container label directions.
5. Lightly sand and reapply if desired.
6. Allow the final coat to dry for 24 hours before reinstalling the trim to the cabinet interior components.

Reversing the Door

(Black Units Only)

All U-Line units (except Stainless Steel models) may be left- or right-hand opening. The door opening is easily reversed by moving the hinge hardware to the opposite side. The top hinge hardware will be used on the bottom of the other side and the bottom hinge hardware will be used on the top of the other side (see **Figure 6**).

To reverse the door:

1. Remove top hinge screw pin from door (Phillips screwdriver) (see **Figure 7**). Remove door by tilting forward and lifting off bottom hinge pin.
2. Remove metal hinge screw plugs (3 each, top and bottom) from new hinge location. Do not discard (see **Figure 8**).

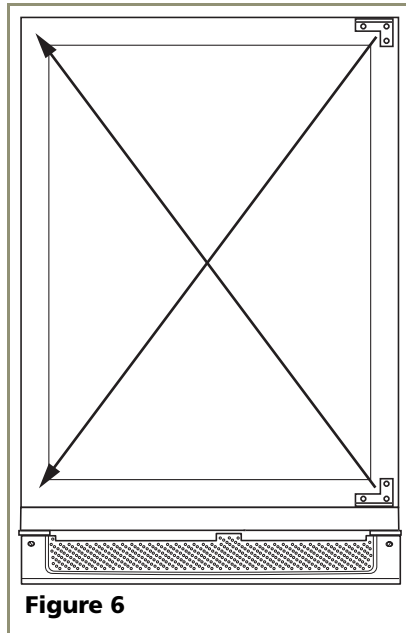

Figure 6

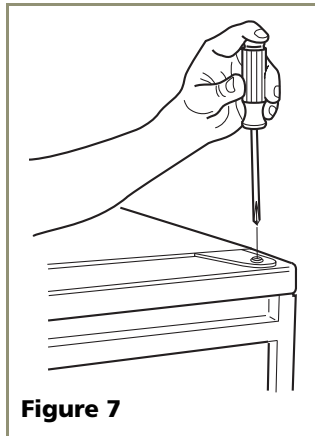

Figure 7

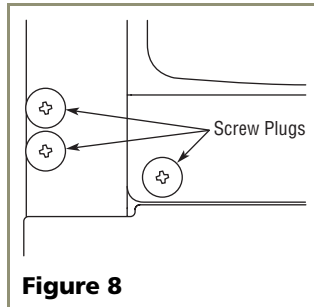

Figure 8

3. Remove top hinge (3 screws), reinstall hinge screw pin, and remount on opposite side **BOTTOM** (see **Figure 9**).
4. Remove the two door closer inserts from the existing bottom hinge and install as shown on the new bottom hinge (see **Figure 10**).

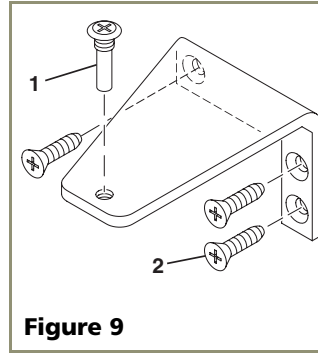

Figure 9

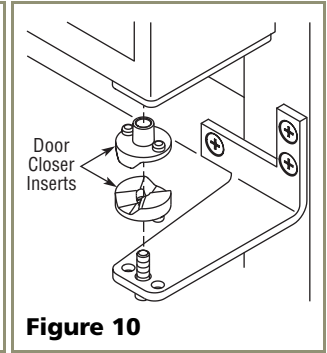

Figure 10

5. Remove existing bottom hinge (3 screws) and remount on opposite side **TOP**. Remove hinge screw pin.
6. Remove the plastic hole plug from the top of the door to allow the pivot pin to be inserted in the new location. Install the plug into the vacated hole on the opposite side.
7. With bottom of door facing up, remove pivot plate (2 screws), flip over, and remount on opposite side of door (see **Figure 11**). Be sure angled side of plate faces center.

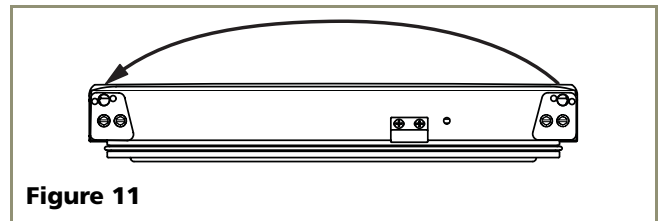

Figure 11

8. Holding door upright with top of door tilted forward, place hole of door pivot plate on bottom hinge screw pin (see **Figure 12**).
9. Tilt top of door into position in top hinge and install top hinge screw pin.
10. Install metal hinge screw plugs removed in Step 2 in old hinge holes (3 each, top and bottom).
- 11.

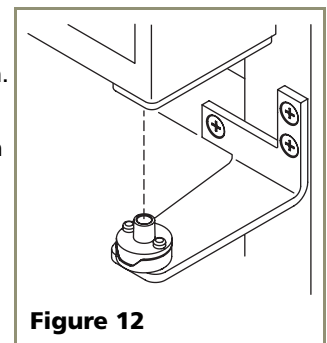

Figure 12

Overlay Frame

(2175WCOL2 Units Only)

FRAME PREPARATION

IMPORTANT

The thickness of the wood overlay panel must be 3/4".

1. Use the following instructions to create or have a wood overlay panel created for your Échelon Wine Captain or Beverage Center model as shown in **Figure 13**.
2. Drill holes for pivot pins, upper door hinge and lower door hinge as shown.
3. The overlay door panel must be installed in accordance with the Installation Instructions starting on page 9.

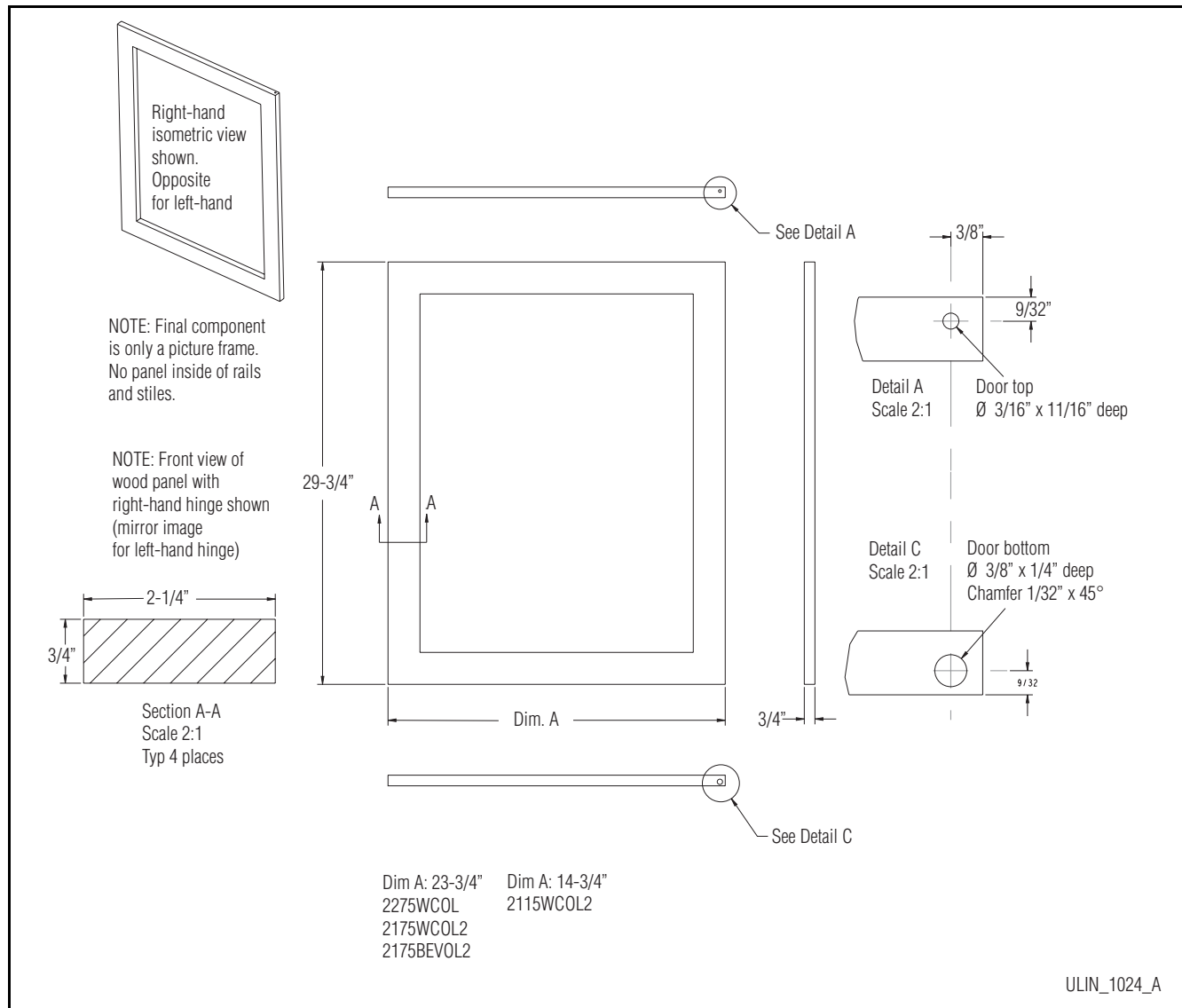

Figure 13

PREPARE THE NEW OVERLAY PANEL

IMPORTANT

The overlay door panel must not weigh more than 20 lbs. The thickness of the door panel must be 3/4".

1. Place a towel, or other similar, soft, non-marking material out on a flat clean surface. Be sure the material is large enough to have the wood panel not touch the hard, marking surface.
2. Lay the wood panel out with the front side of the wood facing down.
3. Cut the foam tape into four pieces, two pieces the width of the overlay and two pieces the height of the overlay.
4. Remove adhesive protection strip from one piece of the cut foam and align the edge of the foam tape to the inside edge of the overlay as shown, adhering the foam tape to the overlay (**Figure 14**).

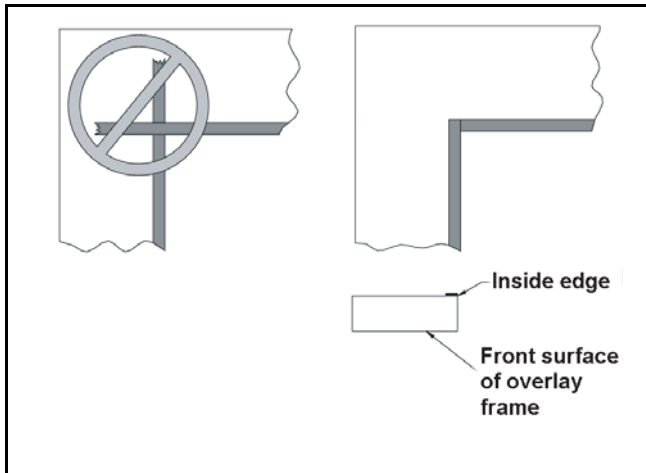

Figure 14

5. Trim each piece of tape immediately after applying it to the overlay. Do not allow any overlapping of the foam tape. Damage to the overlay can occur if the foam tape is not trimmed correctly (**Figure 14**).
6. If required, attach any optional cabinet hardware to the wood panel at this time. If an optional cabinet handle is installed, make sure the mounting screw heads are below (countersunk) the back surface of the overlay.

Note: After attaching the optional cabinet hardware, additional supports may be needed to keep panel flat for next steps.

ATTACHING THE OVERLAY PANEL

7. Remove the top hinge pivot pin with a Phillips screwdriver and lift door off bottom hinge pin (**Figure 15**). Be careful not to lose the door closer insert sets. Save pivot pin for use later.

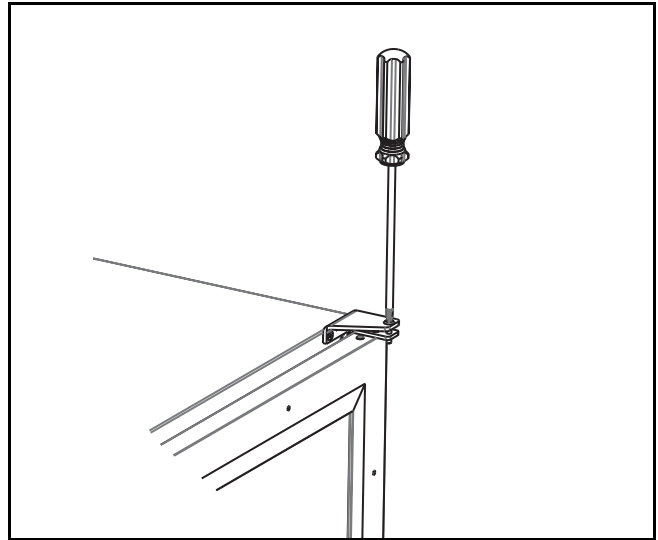

Figure 15

8. Carefully lay the door over the wood panel, making sure door is orientated correctly (top of door with top of wood overlay).
9. Pull door gasket out of the groove completely. Start in the middle and pull outward, moving towards the corners (**Figure 16**). This may take some force, but be careful not to cut or rip the gasket.

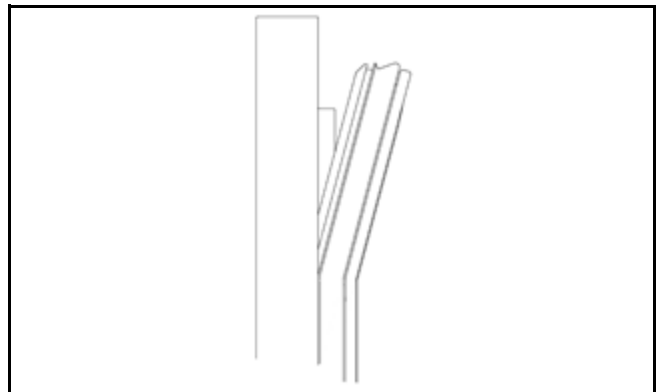

Figure 16

10. After gasket has been removed, place it on a flat, clean surface.
11. Secure door to the back of the wood overlay using tape on all four corners. Make sure all four edges are aligned (**Figure 17**).

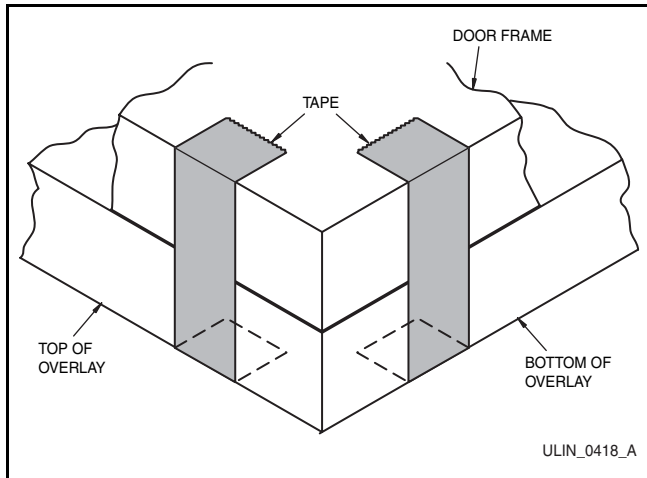

Figure 17

12. Use the door frame holes as a guide to lightly punch pilot holes for the #6 x 1" pan head screws (Figure 18).

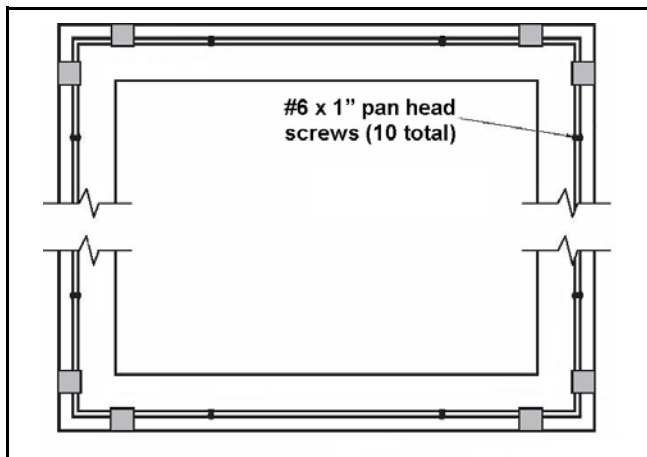

Figure 18

13. Attach the door to the overlay using #6 x 1" wood screws.

IMPORTANT

If you decide to drill pilot holes, remove the wood overlay from the door, and do not use a drill larger than 7/64", and do not drill deeper than 3/8". The door frame and wood overlay must be aligned properly or the door will not operate correctly.

*Note: After attaching the wood to the door, double check the bottom pivot hole location. If the hole in the pivot bracket is covered by any wood, chase thru the hole with a 11/32" drill to open hole in door panel. **DO NOT** drill deeper than 1/4" deep.*

ASSEMBLING DOOR TO CABINET

14. Starting at the corners and working toward the center, push the door gasket back into place. Make sure gasket is fully seated on all four sides and corners.

- 15. Check the closure assembly on the bottom hinge to be sure it is seated correctly in the bosses in the hinge.
- 16. Position door over closer. Be sure the door hinge plate holes align with the bosses on the closer (Figure 19). Failure to do so will result in the door not sitting in the proper position and door will not align correctly. (Sometimes it is helpful to open the door 180° to have the closer and pivot plate align correctly.)

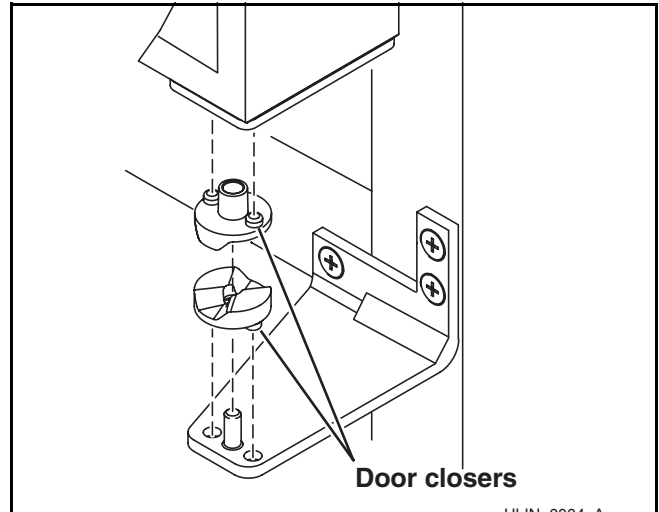

Figure 19

- 17. Holding the door in the closed position, install the pivot post (removed in step 7) thru the top hinge into the top pivot plate. Tighten securely with a Phillips screwdriver, making sure post is seated fully.
- 18. Adjust door as needed for proper closure. Refer to the following section for adjustment procedures.

5 Adjust Door

Checking Door Alignment

The unit's door is aligned at the factory before shipment. However, its alignment could have been disturbed during shipment or during overlay frame installation.

IMPORTANT

Properly aligned, the door should be 1/8" below the top of the unit's cabinet, NOT flush with the top (see **Figure 20**).

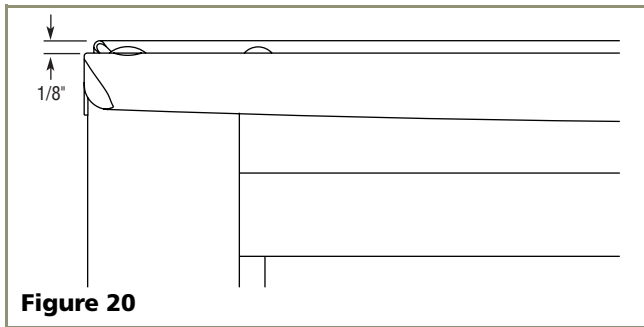

Figure 20

1. Compare the top edge of the door to the top edge of the cabinet.
2. If the door edge is 1/8" below and parallel to the top of the cabinet, go on to **6 Prepare Power Supply**. If it is not, note whether the side opposite the hinge needs to be moved UP or DOWN, and use the following procedure.

Adjusting Door Alignment

1. Remove top hinge screw pin (Phillips screwdriver, see **Figure 21**). Remove door by tilting forward and lifting off bottom hinge pin.
2. With door upside-down, loosen but do not remove the two screws on the door's bottom hinge plate.

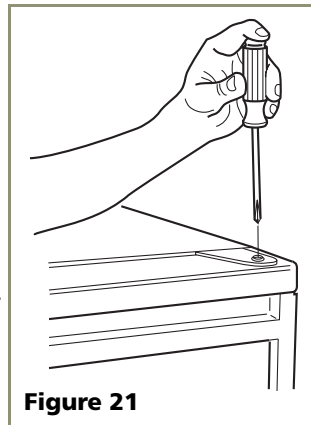

Figure 21

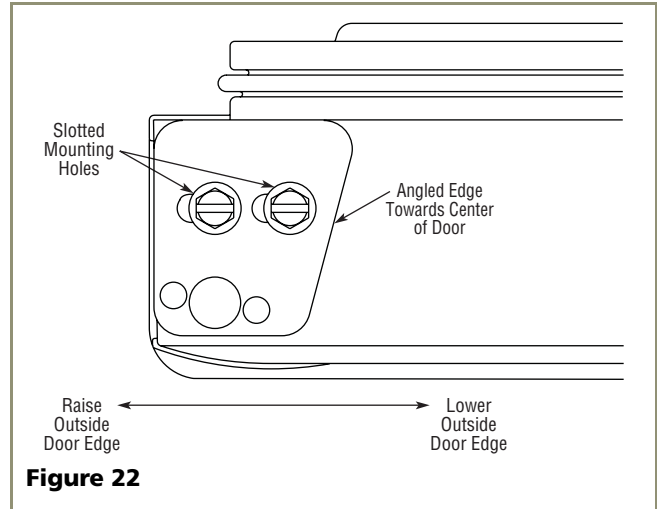

Figure 22

3. See **Figure 22**. If the top far edge of the door needs to move UP, move the hinge plate toward the outside of the door and retighten screws. If the top far edge of the door needs to move DOWN, move the hinge plate toward the inside of the door and retighten screws.
4. Mount the door to recheck alignment and repeat Steps 2 and 3 if further adjustment is necessary.
5. When top edge of door is parallel to top edge of cabinet, remove the door and ensure the two screws are secure.
6. Remove the door closers from the bottom hinge, clean thoroughly and lubricate the mating surfaces with petroleum jelly.
7. Reinstall the closers, lining up the bosses with holes in hinge and hinge plate (see **Figure 23**).
8. Mount the door, install top hinge pivot pin and go on to **6 Prepare Power Supply**.

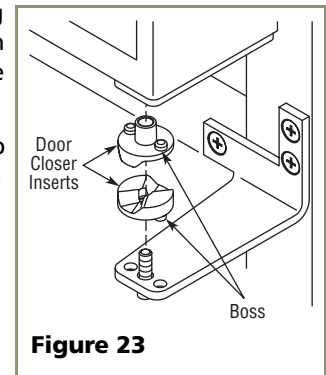

Figure 23

6 Prepare Power Supply

Electrical Specifications

CAUTION

Electrical installation must observe all state and local codes. This unit requires connection to a grounded (three-prong), polarized receptacle that has been placed by a qualified electrician.

The unit requires a grounded and polarized 115 VAC, 60 Hz, 15A power supply (normal household current). An individual, properly grounded branch circuit or circuit breaker is recommended. GFCI (ground fault circuit interrupter) is usually not required for fixed location appliances and is not recommended for your unit because a GFCI could be prone to nuisance tripping. However, be sure to consult your local codes.

See **Figure 24** for recommended receptacle location.

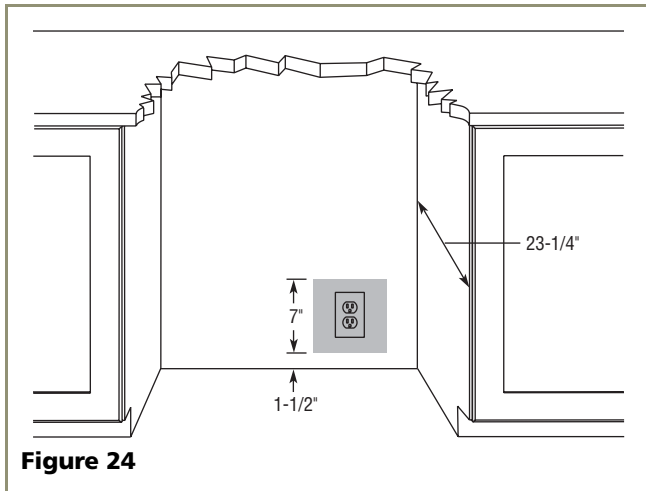

Figure 24

WARNING

SHOCK HAZARD — Electrical Grounding Required.

- **Never remove the round grounding prong from the plug and never use a two-prong grounding adapter.**
- **Never use an extension cord to connect power to the unit.**

Go on to **7 Level the Unit**.

7 Level the Unit

Leveling Information

Note: It is recommended that the unit is level.

1. Use a level to check the levelness of the Wine Captain® from front to back and from side to side. Level should be placed along top edge and side edge as shown (see **Figure 25**).

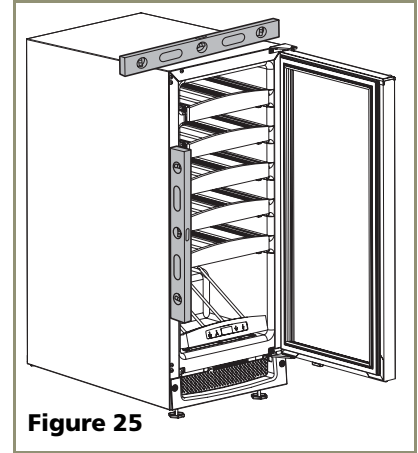

Figure 25

2. If the Wine Captain® is not level, adjust the feet on the corners of the unit as necessary (see **Figure 26**).

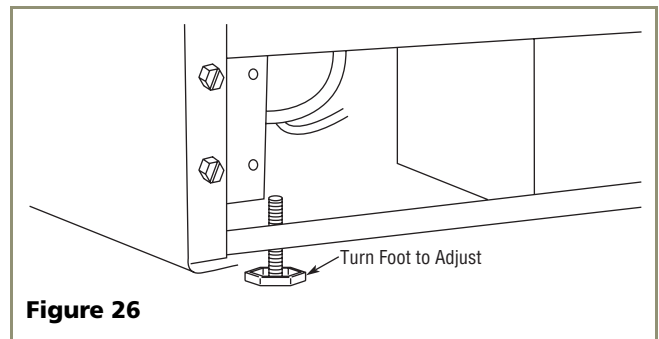

Figure 26

3. Check the levelness after each adjustment and repeat the previous steps until the unit is level. Go on to **8 Install the Unit**.

Installation Tip

If the room floor is higher than the floor in the cut-out opening, adjust the rear feet to achieve a total unit rear height of 1/8" less than the opening's rear height. Shorten the unit height in the front by adjusting the front feet. This allows the unit to be gently tipped into the opening. Readjust the front feet to level the unit after it is correctly positioned in the opening.

8 Install the Unit

Anti-Tip Bracket Installation

1. Locate two Anti-Tip Brackets included inside the unit.
2. Place the unit into the area where it will be installed. Check the door, sides and top for a proper fit. Also test to make sure the door opens and closes freely.
3. Remove grill and place a mark on the floor at the front of the unit. Also place a mark on the floor in the center of the unit. See **Figure 27**.

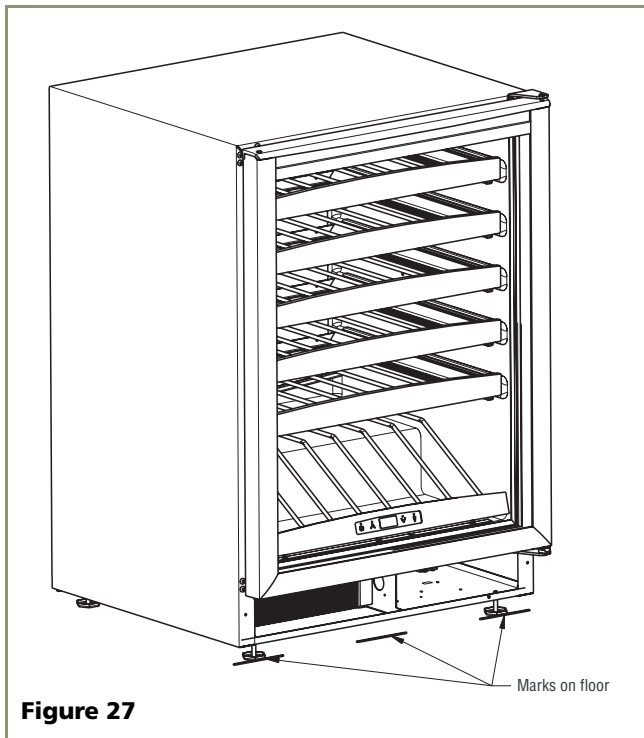

Figure 27

4. Remove the unit. Using a square, extend a centerline 20-1/4" toward the back wall. See **Figure 28**. At the back of the centerline, mark a line that measures 11-1/16" to the left and right. This line serves as the back edge for the Anti-Tip Brackets and its furthest points mark the outer edge of each bracket.

Note: Instructions are shown for built-in installation. Use same dimensions for free-standing installation.

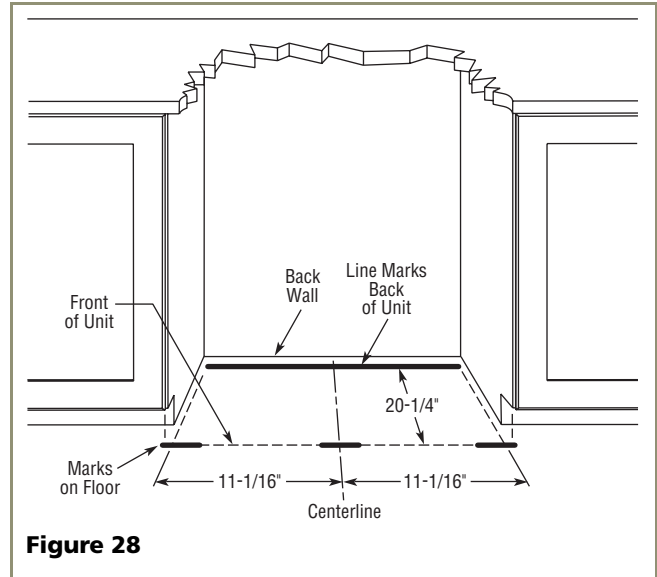

Figure 28

5. Place the Anti-Tip Brackets on the floor against the line drawn for the outer edge. Mark spots for the screw holes. See **Figure 29**.

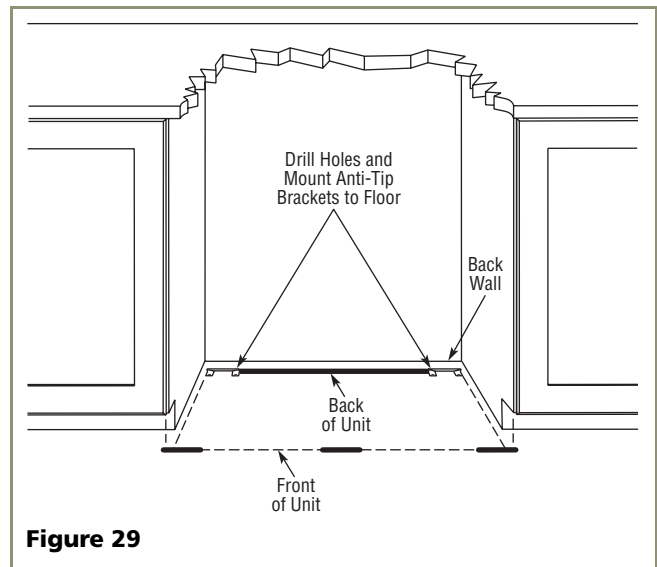

Figure 29

6. Use a 1/8" drill to make two starter holes and fasten the Anti-Tip Brackets to the floor using the screws provided.

⚠ CAUTION

Other hardware is required for floors made of materials other than wood.

7. Place the unit back into position, making sure the feet engage the Anti-Tip Brackets properly. Check the alignment of the lines made on the floor in Step 3 with the position of the front feet to ensure proper positioning.

Single Unit Installation

1. Remove the two screws from the opposite side of the hinge assembly using a Phillips screwdriver (**Figure 30**).

Right-handed units shown, Left-handed units are mirrored

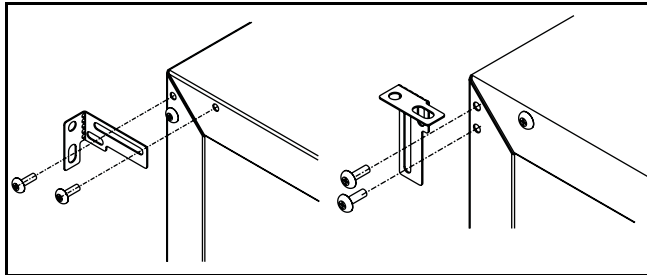

Figure 30

2. Place bracket (part # 14154) over holes and attach to unit with two screws removed in step 1 using a Phillips screwdriver. Tighten screws fully.
3. Recheck the leveling, from front to back and side to side. Make any necessary adjustments. The unit's top surface should be approximately 1/8" below the countertop.
4. Secure bracket into adjoining surface.

Side-by-Side Installation

1. Remove screws shown (**Figure 31**).

CAUTION

Be sure to remove and discard screw shown. Failure to do so may cause damage to the bracket and/or unit.

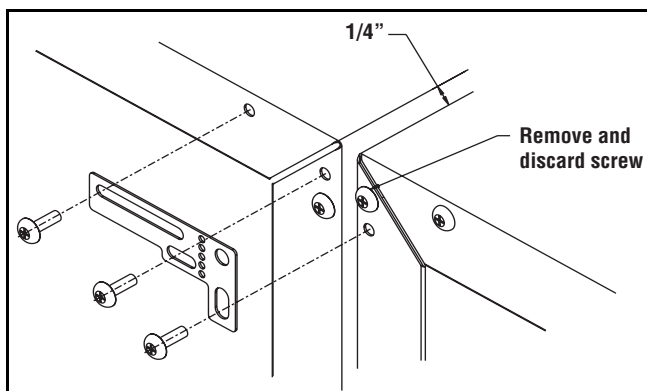

Figure 31

2. Place bracket as shown, and re-attach screws to unit using a Phillips screwdriver. Tighten screws fully.
3. Recheck the leveling, from front to back and side to side. Make any necessary adjustments. The unit's top

surface should be approximately 1/8" below the countertop.

Installation Troubleshooting

Q: Problem

The door remains open unless it is pushed closed.

A: Solution

The hinges should be self-closing when the door is open approximately 8". If this is not the case, make sure the closers (at the bottom of the hinge pin) are clean, greased and installed correctly. Also, re-check leveling from front to back of the unit and readjust if necessary. Make sure that pivot plate is installed correctly.

9 Start-Up for the First Time

Initial Start-Up

The unit is shipped with the control preset. No adjustments should be necessary at this time. For information about Adjusting the Temperature Control, see the Use and Care Guide.

Start-Up Troubleshooting

Q: Problem

Unit does not appear to turn on when plugged in.

A: Solution

Make sure outlet has power (circuit breaker has not tripped). Check to see that control is turned on.

Q: Problem

Light is on with door closed.

A: Solution

Touch the **LIGHT** icon on the display panel. This will cancel out the light function and just allow the light to turn on and off with the door opening and closing.

The Wine Captain® has an interior light that is illuminated when the door is opened. The light can be left on while the door is closed by pressing the **LIGHT** icon. This will turn interior light on for 4 hours, then it will turn off.

IMPORTANT

See the Use and Care Guide's *Troubleshooting Guide* for more solutions.

Who to Call

Service Information

If the need for service arises, call the U-Line Customer Care Center directly @ **800-779-2547**. To ensure accurate assistance, please have your Model Number and Serial Number and an explanation of the problem. The Model and Serial Number plate is located inside unit at upper right hand corner.

If you need to locate a service company, you can go online at **www.U-LineService.com** and search for a service company by zip code.

For more than four decades, U-Line has distinguished itself as the leader in built-in undercounter ice making, refrigeration and wine storage appliances.

U-Line Corporation, located in Milwaukee, WI, is a family operated manufacturer of built-in undercounter icemakers, Combo® icemaker/refrigerators, Wine Captain® wine storage units, refrigerators, refrigerated drawers and refrigerator/freezers.