

Frigidaire

Factory Parts Catalog

Product No.	FGHS2669KE0	FGHS2669KP0	FGHS2679KE0	FGHS2679KP0
Series	Gallery	Gallery	Gallery	Gallery
Color	black	white	black	white
Volts	115	115	115	115
Wiring Diagram	241912901	241912901	241912901	241912901
Owner's Guide	241979200	241979200	241979200	241979200
Market	North America	North America	North America	North America
Energy Guide	241935565	241935565	241935566	241935566
Service Data Sheet	240389638	240389638	240389638	240389638

 **Electrolux**

Electrolux Major Appliances
 North & Latin America
 P.O. BOX 212378
 AUGUSTA, GA 30917

Publication No.
5995532701
 09/02/06
 (EN/SERVICE/KHB)
 137

**SIDE-BY-SIDE
 REFRIGERATOR**

Model No.
**FGHS2669K /
 FGHS2679K**

Copyright © 2009 Electrolux Home Products, Inc.
 All rights reserved.

FREEZER DOOR

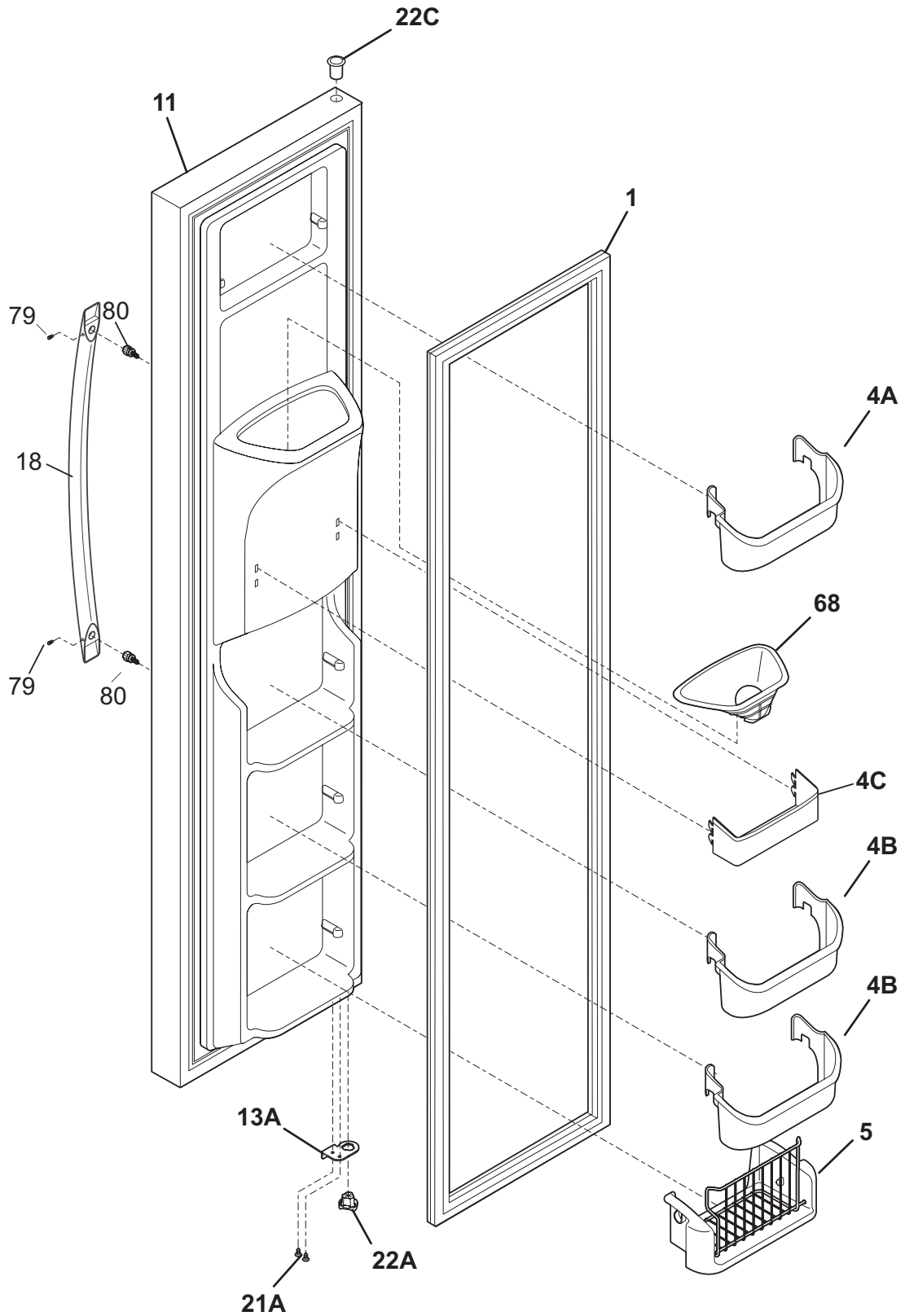

F58FFDCFA0

FREEZER DOOR

Model Index: **A** FGHS2669K (FGHS2669KE0)
 B FGHS2669K (FGHS2669KP0)
 C FGHS2679K (FGHS2679KE0)
 D FGHS2679K (FGHS2679KP0)

POS. NO	PART NO.		DESCRIPTION
1	241786006	A - C -	Gasket-frzr door, black, magnetic
1	241786002	- B - D	Gasket-frzr door, white, magnetic
4A	240334201	A B C D	Bin-door, frzr-upper
4B	240351601	A B C D	Bin-door
4C	240351701	A B C D	Bin-door, frzr-dispenser
5	241545005	A B C D	Bin-tilt out, tilt-out
11	241837192	A - C -	Door-frzr, black, complete assy
11	241837188	- B - D	Door-frzr, white, complete assy
13A	241942604	A B C D	Door Stop, black, frzr
18	241930103	A - - -	Handle-door, black
18	241930102	- B - -	Handle-door, white
18	241930101	- - C D	Handle-door, white
18*	241601002	A B C D	Wrench, allen
21A	240442706	A B C D	Screw-#10-32 X 3/4, zinc
22A	241990302	A B C D	Bearing-hinge(frz), closer
22C	241760402	A - C -	Bearing, hinge, top
22C	241760401	- B - D	Bearing, hinge, top
68	241946601	A B C D	Chute-ice
79	218755402	A B C D	Screw-set, 10-32 x 0.375
80	218755504	A B C D	Screw-shoulder, #10 AB, handle mounting
*	240352102	A B C D	Connector-water, straight
*	240451503	A B C D	Screw, ind hex wshr hd, 8-32 x 0.375, trilobe
* #	241834703	A B C D	Harness-wiring, door
*	5303918371	A B C D	Dispenser heater kit, 115

REFRIGERATOR DOOR

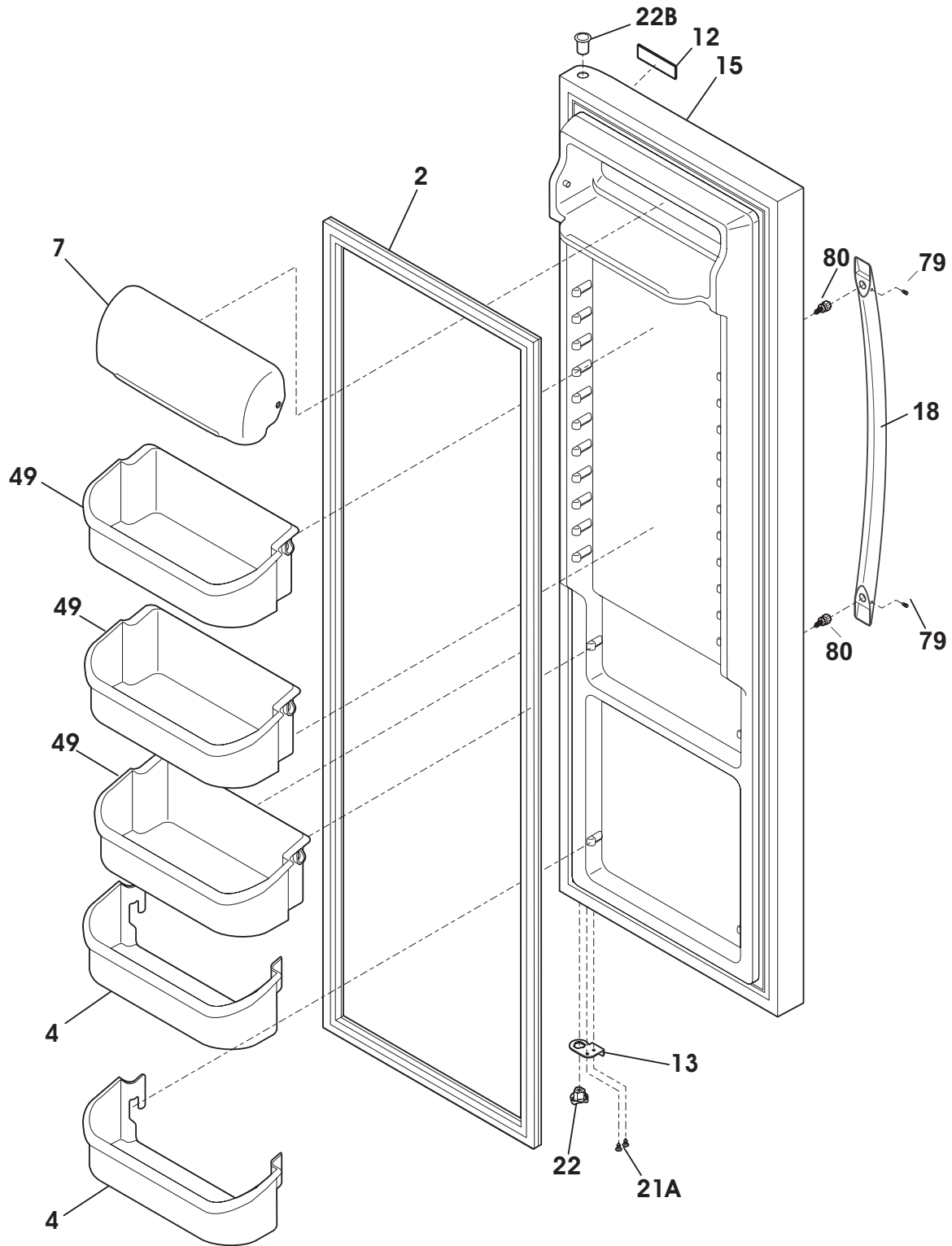

F58RFDA00

REFRIGERATOR DOOR

Model Index: A FGHS2669K (FGHS2669KE0)
 B FGHS2669K (FGHS2669KP0)
 C FGHS2679K (FGHS2679KE0)
 D FGHS2679K (FGHS2679KP0)

POS. NO	PART NO.		DESCRIPTION
2	241786005	A - C -	Gasket-refr door, black, magnetic
2	241786001	- B - D	Gasket-refr door, white, magnetic
4	240323002	A B C D	Bin-door, pseudo, bottom
7	240326203	A B C D	Door-dairy
12	242015201	A B C D	Label-nameplate
13	241942603	A B C D	Door Stop, black, ref
15	241837263	A - C -	Door-refr, black, complete assy
15	241837264	- B - D	Door-refr, white, complete assy
18	241930103	A - - -	Handle-door, black
18	241930102	- B - -	Handle-door, white
18	241930101	- - C D	Handle-door, white
18*	241601002	A B C D	Wrench, allen
21A	240442706	A B C D	Screw-#10-32 X 3/4, zinc
22	241990301	A B C D	Bearing-hinge, gray
22B	241760404	A - C -	Bearing, hinge, top
22B	241760403	- B - D	Bearing, hinge, top
49	241808221	A B C D	Bin-door, gallon
49*	241780403	A B C D	Liner, bin, bin
79	218755402	A B C D	Screw-set, 10-32 x 0.375
80	218755504	A B C D	Screw-shoulder, #10 AB, handle mounting

CABINET

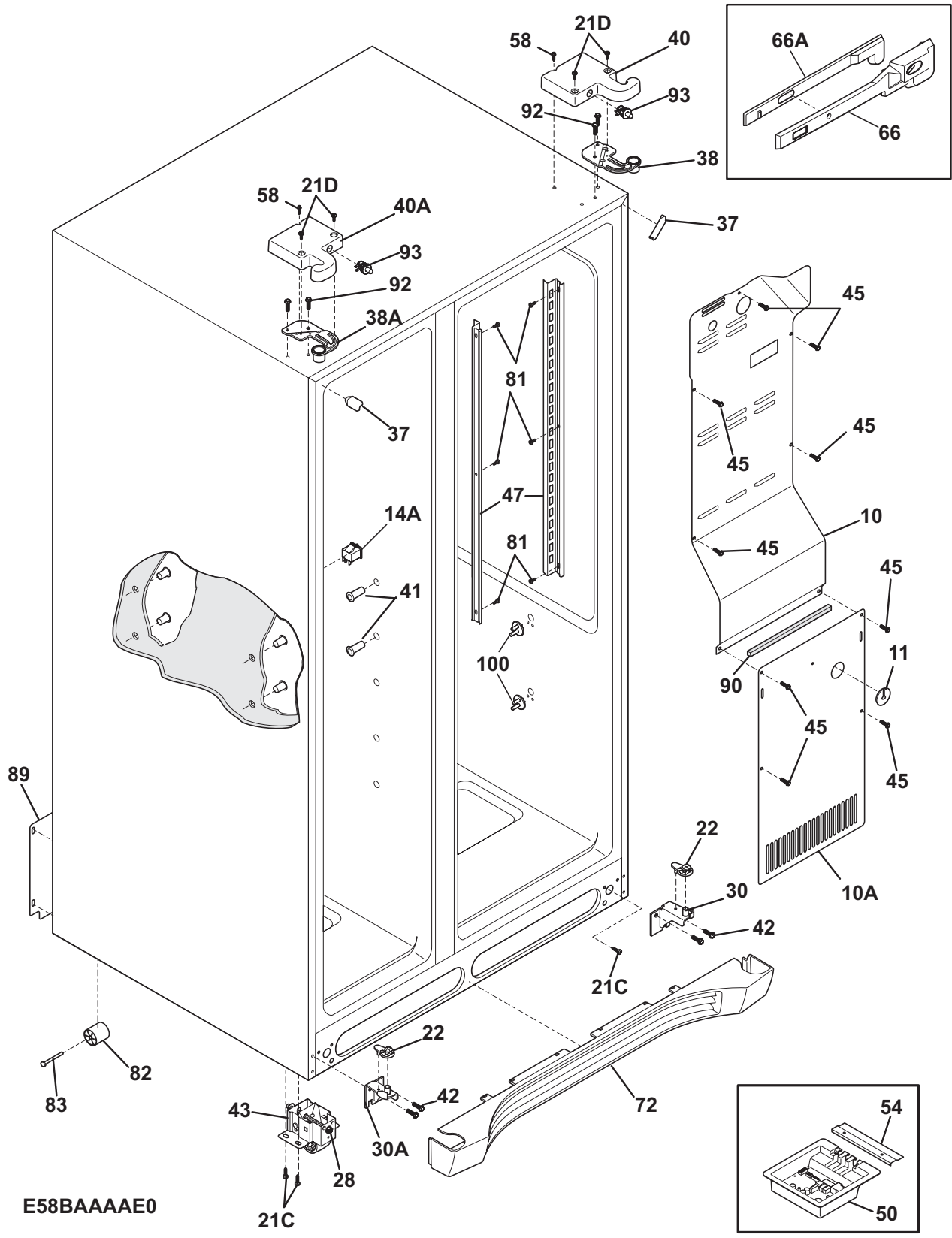

CABINET

Model Index: A FGHS2669K (FGHS2669KE0)
 B FGHS2669K (FGHS2669KP0)
 C FGHS2679K (FGHS2679KE0)
 D FGHS2679K (FGHS2679KP0)

POS. NO	PART NO.		DESCRIPTION
10	240435914	A B C D	Cover-air duct
10A	241719711	A B C D	Cover-evap coil, lower
11	5303208309	A B C D	Plug-hole, factory test
14A#	241547901	A B C D	Switch-light/lamp, frzr door
21C	218252201	A B C D	Screw, #8 truss hd, 10-32CA x 0.500
21D	241548003	A B C D	Screw, 10-32 x 3/8
22	241917801	A B C D	Plate-door closer
28	240335502	A B C D	Bolt-roller adj, hex washer head, 1/4-20 x 4.020, (2), special
30	241917901	A B C D	Bracket-lower hinge, RH, w/hinge pin
30A	241917902	A B C D	Bracket-lower hinge, LH, w/hinge pin
37	240337610	A - C -	Trim-cabinet corner, black, (2)
37	240337608	- B - D	Trim-cabinet corner, white, (2)
38	241761301	A B C D	Bracket-upper hinge, RH
38A	241761302	A B C D	Bracket-upper hinge, LH
40	241946705	A - C -	Cover-upper hinge, black, RH
40	241946701	- B - D	Cover-upper hinge, white
40*	241835801	A B C D	Harness-wiring
40A	241946706	A - C -	Cover-upper hinge, black, LH
40A	241946702	- B - D	Cover-upper hinge, white, LH
40A*	241891901	A B C D	Harness-wiring, freezer
41	241550801	A B C D	Grommet-shelf mtg, 1.40" long
41*	241550701	A B C D	Grommet-shelf mtg, .96" long
42	240578902	A B C D	Screw, hex head, 1/4-20 x 5/8
43	240335006	A B C D	Roller Assy, front, (2)
45	241500303	A B C D	Screw, hex washer head, 8-18AB x 0.500
47	241513001	A B C D	Channel-shelf mtg, side, (2)
50	242000406	A B C D	Board-main power
50*	241867901	A B C D	Harness-wiring
54	241532401	A B C D	Channel
58	218781101	A B C D	Screw, pan head, 8-18 x 0.625
66	241756801	A B C D	Damper-meat keeper
66*	241512807	A B C D	Seal
66A	241756901	A B C D	Housing-damper
72	241969403	A - C -	Grille/Kickplate, black
72	241969401	- B - D	Grille/Kickplate, white
81	5304455650	A B C D	Screw, hex washer head, 8-15A x 0.625, low profile
82	5304418225	A B C D	Roller, compressor base, rear, (2)
83	5304455655	A B C D	Rivet, flat head, 1/4 OD x 1-3/4, roller pin
89	241733905	A B C D	Cover-access, w/label
90	218249808	A B C D	Seal-coil cover
92	241710601	A B C D	Screw, hex washer hd, 1/4 x 7/8, hinge mtg
93	241911704	A - C -	Switch, plunger style
93	241911701	- B - D	Switch, plunger style
100	240423701	A B C D	Support, crisper cover, front, (4)
100*	240350802	A B C D	Support, crisper cover, rear, (4)
*	241852501	A B C D	Clip, wiring harness
*	241868101	A B C D	Air Guide

SHELVES

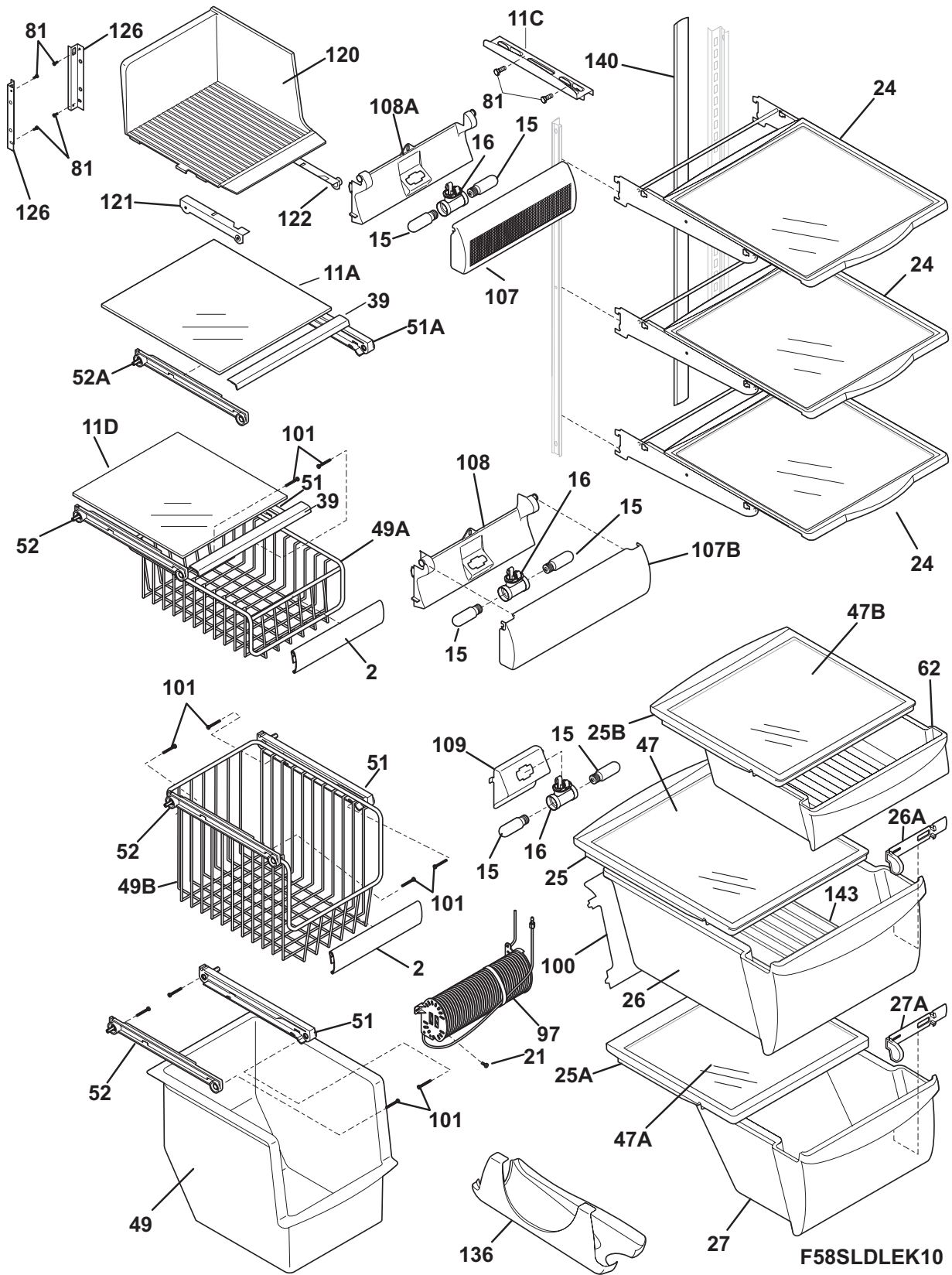

SHELVES

Model Index: A FGHS2669K (FGHS2669KE0)
 B FGHS2669K (FGHS2669KP0)
 C FGHS2679K (FGHS2679KE0)
 D FGHS2679K (FGHS2679KP0)

POS. NO	PART NO.	A	B	C	D	DESCRIPTION
2	241510607					Trim-basket
11A	240350604					Shelf-freezer, glass, upper
11C	240324101					Shelf-pizza
11D	240350605					Shelf-freezer, glass, lower
15	241552801					Light Bulb
16	241622802					Socket-light
16*#	241797601					Harness-wiring
21	5304455658					Screw, hx wshr hd sems, 8-15A x 0.625
24	240350136					Shelf-"Spill-Safe", cantilever, sliding
25	240599302					Cover-crisper pan, upper
25*	240362101					Clip-slide, cover-crisper
25A	240350902					Cover-crisper pan, lower
25B	241969501					Cover-meat pan
26	240351062					Pan-crisper, upper
26*	240349801					Clip-slide, pan-crisper
26*	241595202					Clip-slide, pan-crisper
26A	241638201					Control-humidity
26A*	241638101					Frame-humidity control
27	240351241					Pan-crisper, lower
27A	240362201					Control-humidity
39	240367602					Trim-shelf, front
47	240350649					Insert-pan cover, glass
47A	240350603					Insert-pan cover, glass
47B	240443384					Insert-pan cover, glass
49	240564401					Basket-sliding
49A	240530502					Basket-sliding, upper, half
49B	240530504					Basket-sliding, upper, full
51	240343002					Hanger-basket, RH
51A	240395502					Hanger-basket, RH
52	240343102					Hanger-basket, LH
52A	240395602					Hanger-basket, LH
62	241969602					Pan-meat
81	5304455650					Screw, hex washer head, 8-15A x 0.625, low profile
97	241532007					Water Tank
100	240326304					Cover-water tank
101	218493101					Screw, hex washer head, 8-18AB x 1-3/4
107	241753601					Shield-light, upper
107B	241513402					Shield-light, meat pan
108	241513301					Cover-wiring, meat pan light
108A	241753701					Housing-light, upper, fresh food
109	241513202					Base-crisper light socket
120	241691901					Shelf-ice cream
121	241561001					Rail-ice cream shelf, LH
122	241692001					Rail-ice cream shelf, LH
126	241674401					Channel, auger mtg, LH
126	241674402					Channel, auger mtg, RH
136	241657701					Dispenser-can, white
140	241812501					Channel, wtr tube cover
143	240423301					Divider-crisper pan
*	241781601					Seal-return air
*	241868101					Air Guide
*	241935565					Energy Guide
*	241935566					Energy Guide

CONTROLS

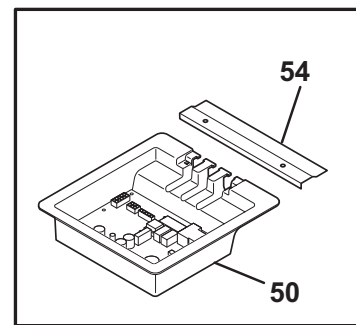
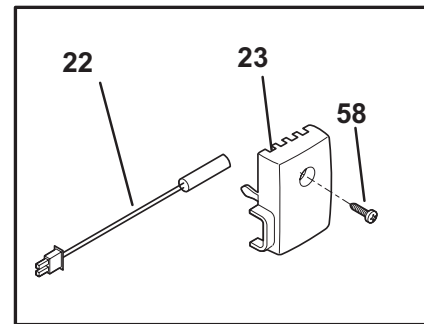
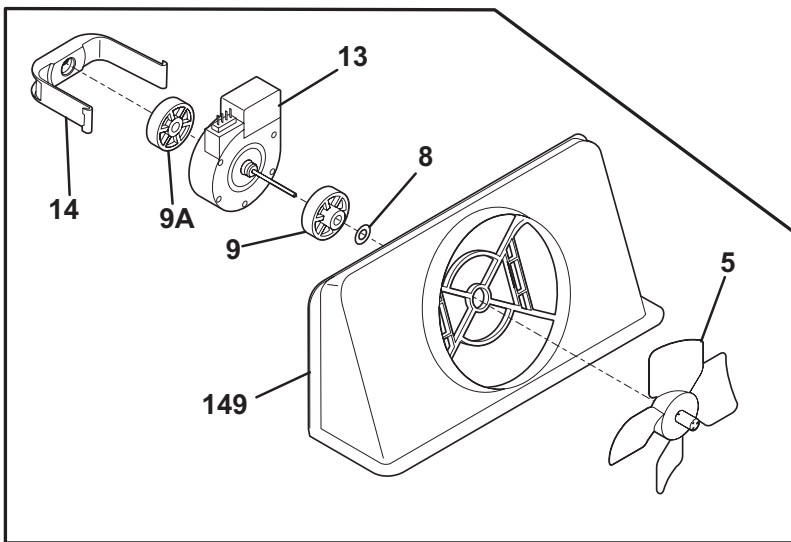
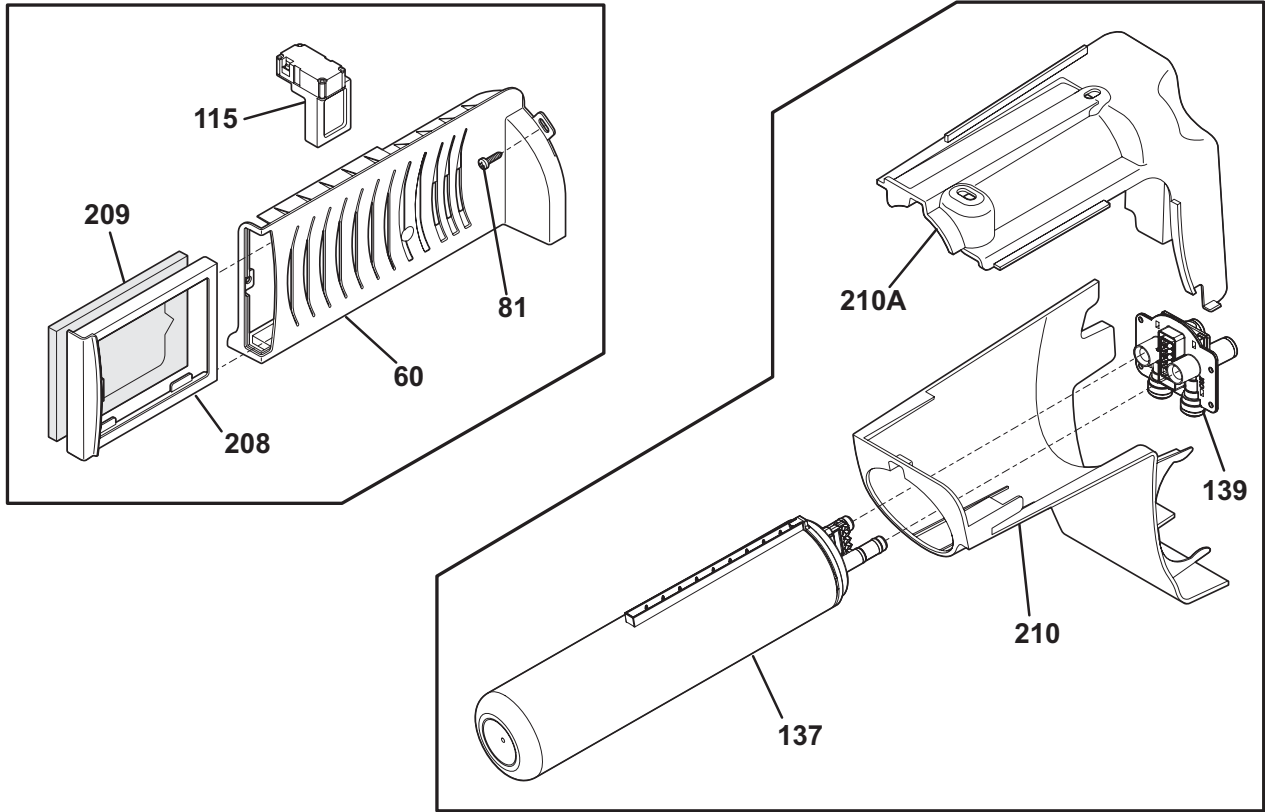

F58TEBCAE0

CONTROLS

Model Index: A FGHS2669K (FGHS2669KE0)
 B FGHS2669K (FGHS2669KP0)
 C FGHS2679K (FGHS2679KE0)
 D FGHS2679K (FGHS2679KP0)

POS. NO	PART NO.	A	B	C	D	DESCRIPTION
5 #	5308000010	A	B	C	D	Fan Blade, red, evaporator fan
8	215474201	A	B	C	D	Washer, "slinger", nylon, evap fan shaft
9	241563601	A	B	C	D	Bushing-motor mtg
9A	241845301	A	B	C	D	Bushing-motor mtg
13	241509402	A	B	C	D	Motor, evaporator fan
14	241517701	A	B	C	D	Clip, evap fan motor
22	240597203	A	B	C	D	Sensor
23	241845401	A	B	C	D	Housing-sensor
50	242000406	A	B	C	D	Board-main power
50*	241867901	A	B	C	D	Harness-wiring
54	241532401	A	B	C	D	Channel
58	5304455650	A	B	C	D	Screw, hex washer head, 8-15A x 0.625, low profile
81	5304455658	A	B	C	D	Screw, hx wshr hd sems, 8-15A x 0.625
60	242010601	A	B	C	D	Housing-diffuser & air filter
60*	241794401	A	B	C	D	Diffuser-air
115	241853801	A	B	C	D	Damper Assy, w/seal
137	241791601	A	B	C	D	Filter-water, carbon
139	242009601	A	B	C	D	Base-water filter
149	241563501	A	B	C	D	Shroud-fan orifice
149*	241528306	A	B	C	D	Seal, shroud
208	241754301	A	B	C	D	Sleeve, air filter, front
209	241754002	A	B	C	D	Filter-air
210	241983801	A	B	C	D	Housing-water filtr
210A	241998301	A	B	C	D	Mount-water filter
*	3205266	A	B	C	D	Edge Protector, wiring harness
*	241852501	A	B	C	D	Clip, wiring harness

SYSTEM

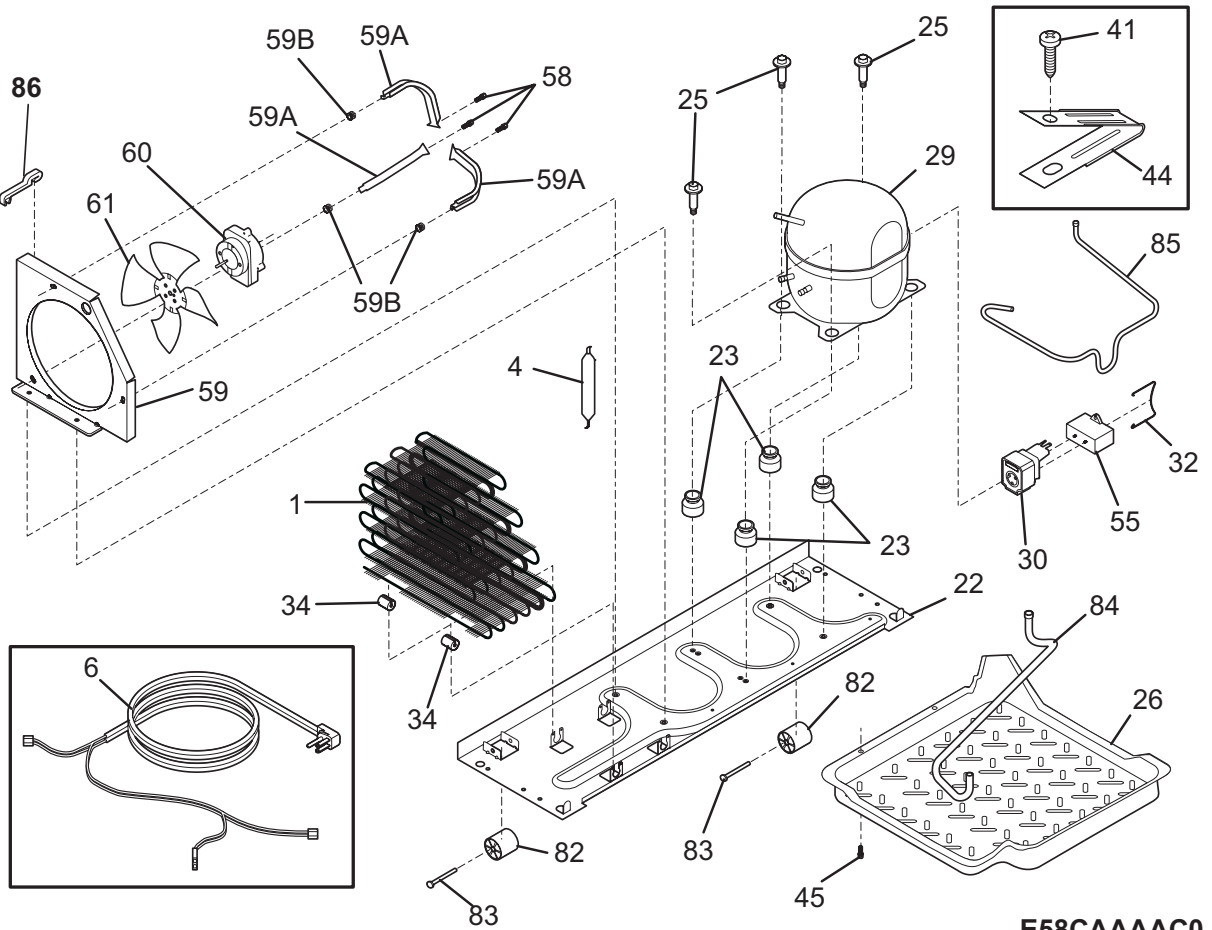
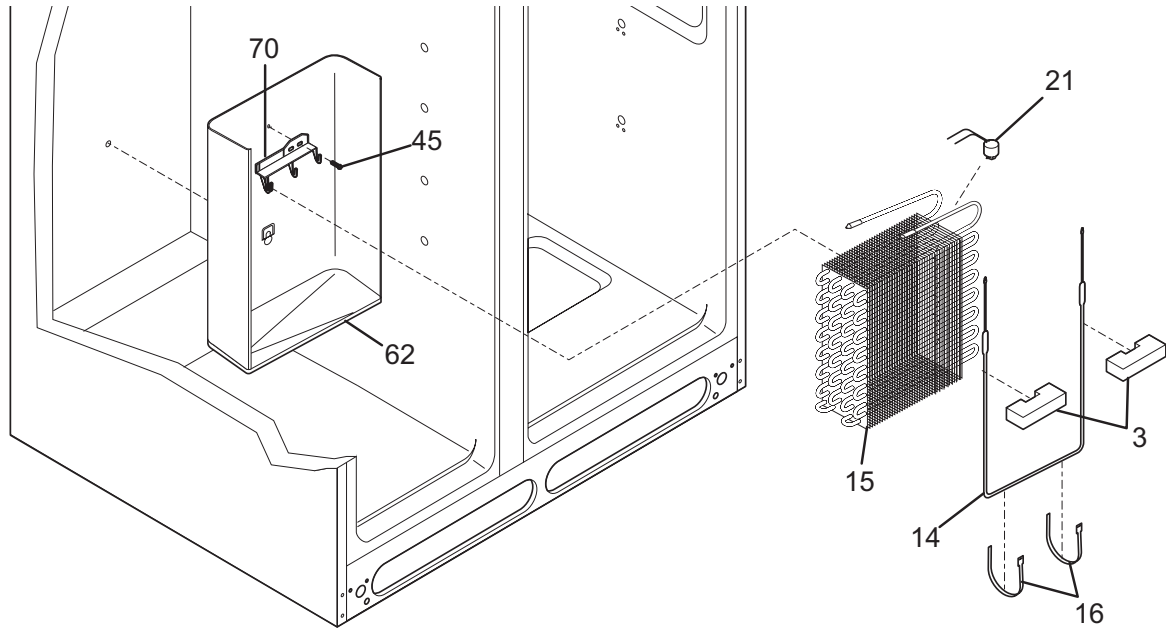

E58CAAAC0

SYSTEM

Model Index: A FGHS2669K (FGHS2669KE0)
 B FGHS2669K (FGHS2669KP0)
 C FGHS2679K (FGHS2679KE0)
 D FGHS2679K (FGHS2679KP0)

POS. NO	PART NO.	A	B	C	D	DESCRIPTION
1	240333603	A	B	C	D	Condenser
3	218679607	A	B	C	D	Block-evap coil, styrofoam, (2)
4 #	218944001	A	B	C	D	Drier-filter, R134a System
6 #	241516901	A	B	C	D	Cord-service
6* #	241834801	A	B	C	D	Harness-wiring, machine compt
6* #	241519902	A	B	C	D	Harness-wiring
14 #	240316107	A	B	C	D	Heater-defrost
15 #	5303918284	A	B	C	D	Evaporator Kit
16	5308000110	A	B	C	D	Strap-evap/heater, aluminum, (2)
21 #	5303918214	A	B	C	D	Thermostat-defrost, kit
22	240330011	A	B	C	D	Base-compressor mtg
22*	218252201	A	B	C	D	Screw, #8 truss hd, 10-32CA x 0.500
23	241659701	A	B	C	D	Grommet, compressor
25	240491503	A	B	C	D	Screw-compressor mtg, 1/4-28 x 1.16, (4)
26	241697602	A	B	C	D	Pan-defrost
29 #	5303918329	A	B	C	D	Compressor, kit, w/electricals
30 #	241707701	A	B	C	D	Starter, PTC
32	241650901	A	B	C	D	Clamp, elec cont mtg, compressor
34	240405201	A	B	C	D	Grommet, rubber, black, cond tube/wire
41	240555002	A	B	C	D	Screw-#8-32 X 3/8
44	215174700	A	B	C	D	Clamp-service cord, strain relief, galv steel
45	5304455650	A	B	C	D	Screw, hex washer head, 8-15A x 0.625, low profile
55	218909913	A	B	C	D	Capacitor, run, 220 VAC, 15 microfarad
58	240433203	A	B	C	D	Screw, hex washer head, 8-18 x 3/8
59	240315502	A	B	C	D	Shroud-cond fan
59*	240346701	A	B	C	D	Tape-foam seal, shroud
59*	240359403	A	B	C	D	Screw-fan shroud, (2)
59A	240346501	A	B	C	D	Bracket-support, cond mtr, (3)
59B	240346601	A	B	C	D	Grommet-bracket, (3)
60 #	241584301	A	B	C	D	Motor-condenser fan
61	241639501	A	B	C	D	Blade-condenser fan
62	240429402	A	B	C	D	Trough-drain
70	218990801	A	B	C	D	Bracket-evap/cvr mtg
82	5304418225	A	B	C	D	Roller, compressor base, rear, (2)
83	5304455655	A	B	C	D	Rivet, flat head, 1/4 OD x 1-3/4, roller pin
84	241957901	A	B	C	D	Tube-drain, lower
85	241856901	A	B	C	D	Tube-connector, suction
86	240409302	A	B	C	D	Spacer-cond tube, black
*	241852501	A	B	C	D	Clip, wiring harness
* #	5303918328	A	B	C	D	Heat Exchanger Kit, suction line, service
*	5303918222	A	B	C	D	Hot Tube Repair Kit, service

ICE & WATER DISPENSER

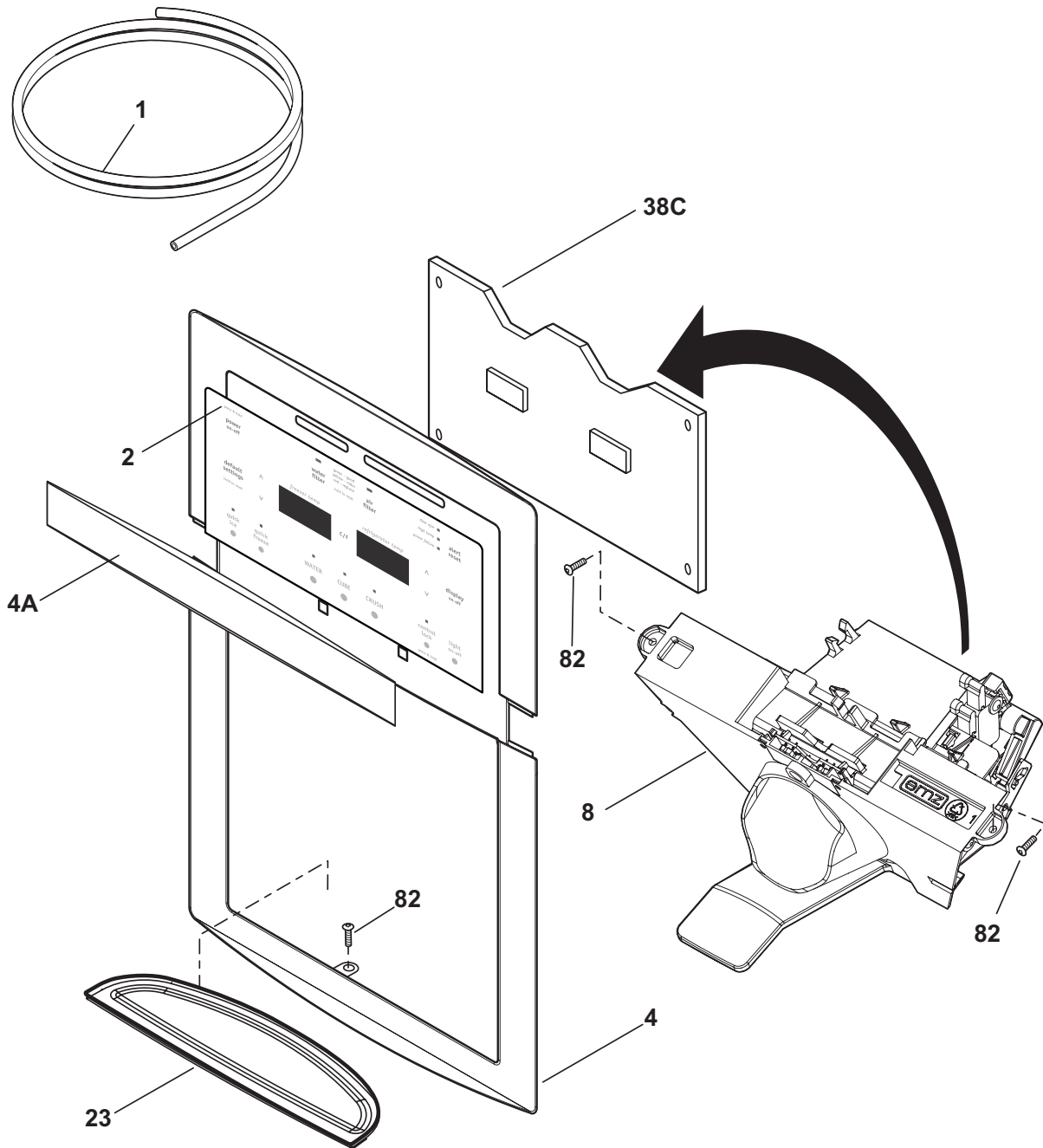

F58XFAAAA0

ICE & WATER DISPENSER

Model Index: **A** FGHS2669K (FGHS2669KE0)
 B FGHS2669K (FGHS2669KP0)
 C FGHS2679K (FGHS2679KE0)
 D FGHS2679K (FGHS2679KP0)

POS. NO	PART NO.		DESCRIPTION
1*	218976419	A B C D	Tube-water inlet, valve to door
1*	218976429	A B C D	Tube-water inlet, 97.50", brown/tan
1*	218976915	A B C D	Tube-water inlet, inlet valve, to filter
1*	240561703	A B C D	Seal-water inlet, inlet valve, to ice maker
2	241973813	A - C -	Switch Assembly, overlay, black
2	241973814	- B - D	Switch Assembly, overlay, white, top
4	241946803	A - C -	Cover-module, black
4	241946801	- B - D	Cover-module, white
4A	241946901	A B C D	Trim, Facade
8	241753413	A B C D	Module-dispenser, clear
23	241947003	A - C -	Drip Tray, black
23	241947001	- B - D	Drip Tray, white
38C#	241973703	A B C D	Board-control
82	240363402	A B C D	Screw-#8-18 X 1/2, #6 hd plask
*	5303918371	A B C D	Dispenser heater kit, 115

ICE CONTAINER

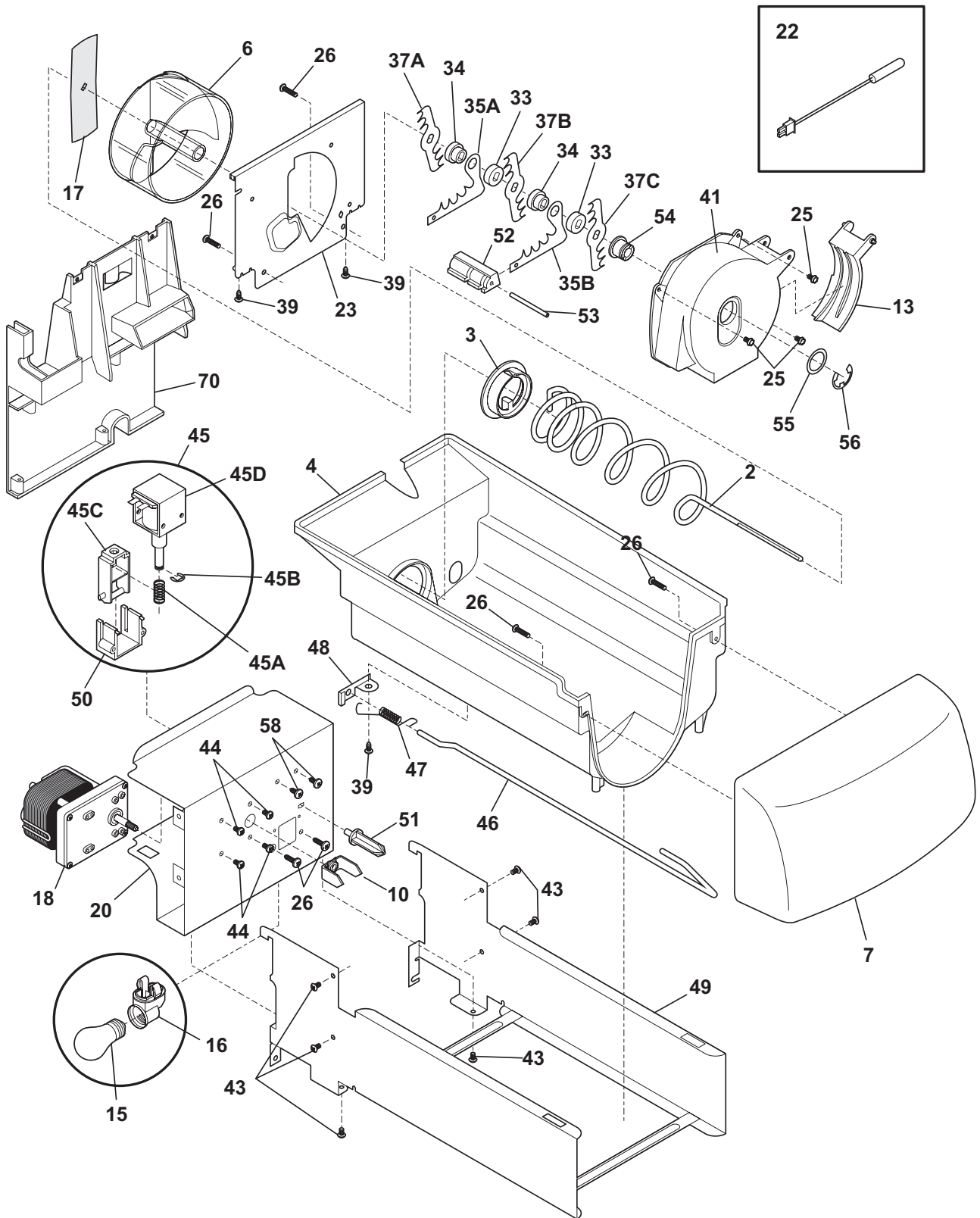

N58YDAAAC5

ICE CONTAINER

Model Index: A FGHS2669K (FGHS2669KE0)
 B FGHS2669K (FGHS2669KP0)
 C FGHS2679K (FGHS2679KE0)
 D FGHS2679K (FGHS2679KP0)

POS. NO	PART NO.	A	B	C	D	DESCRIPTION
2	241716101	A	B	C	D	Auger-ice
3	241685201	A	B	C	D	Cam-drive
4	241561302	A	B	C	D	Container-ice, bucket only
6	241685101	A	B	C	D	Drum-ice disp
7	241561402	A	B	C	D	Front-ice container
10	241726501	A	B	C	D	Bar-drive
13	241685301	A	B	C	D	Gate
15	241555401	A	B	C	D	Light Bulb
16	241559801	A	B	C	D	Socket-light
17	241684501	A	B	C	D	Drive Blade
18 #	241676201	A	B	C	D	Motor-auger
18*	241522901	A	B	C	D	Harness-wiring, icmkr/container
20	241675502	A	B	C	D	Cover-motor
22	240597203	A	B	C	D	Sensor
23	241684001	A	B	C	D	Plate-front
25	241690701	A	B	C	D	Screw, hex washer head, 8-32T x 0.375
26	215503205	A	B	C	D	Screw, cr pan hd, 10-16 x 0.500
33	241684801	A	B	C	D	Spacer
34	241689801	A	B	C	D	Spacer
35A	241684301	A	B	C	D	Fixed Blade, round
35B	241684201	A	B	C	D	Fixed Blade, square
37A	241684101	A	B	C	D	Blade, crusher #1
37B	241684102	A	B	C	D	Blade, crusher #2
37C	241684103	A	B	C	D	Blade, crusher #3
39	241690501	A	B	C	D	Screw
41	241685601	A	B	C	D	Housing-crusher
43	215005101	A	B	C	D	Screw, hanger/rlr mtg, 8-10 x 7/16
44	218359202	A	B	C	D	Screw, pan head, 8-32 x 0.250
45	241675701	A	B	C	D	Solenoid Assy, 115V
45A	241675901	A	B	C	D	Spring-solenoid
45B	241676001	A	B	C	D	E-Ring-solenoid
45C	241676101	A	B	C	D	Actuator-solenoid
45D	241675801	A	B	C	D	Solenoid, 115V
46	241716002	A	B	C	D	Control Rod
47	241731801	A	B	C	D	Spring-control rod
48	241684602	A	B	C	D	Bracket-control rod
49	241734501	A	B	C	D	Rail Assy
50	241675601	A	B	C	D	Guide-solenoid
51	241676301	A	B	C	D	Rotation Stop
52	241684901	A	B	C	D	Spacer-fixed blades
53	241690402	A	B	C	D	Pin-spiral, fixed blades
54	241685001	A	B	C	D	Nut-auger
55	241690306	A	B	C	D	Washer
56	241690201	A	B	C	D	E-ring
70	241561502	A	B	C	D	Plate-mounting
70*	241551602	A	B	C	D	Screw, hex head, 8-18B x 0.875
70*	241716801	A	B	C	D	Clip
*	218817300	A	B	C	D	Shield-light
*	241860810	A	B	C	D	Ice Container Assy, w/moving parts

ICE MAKER

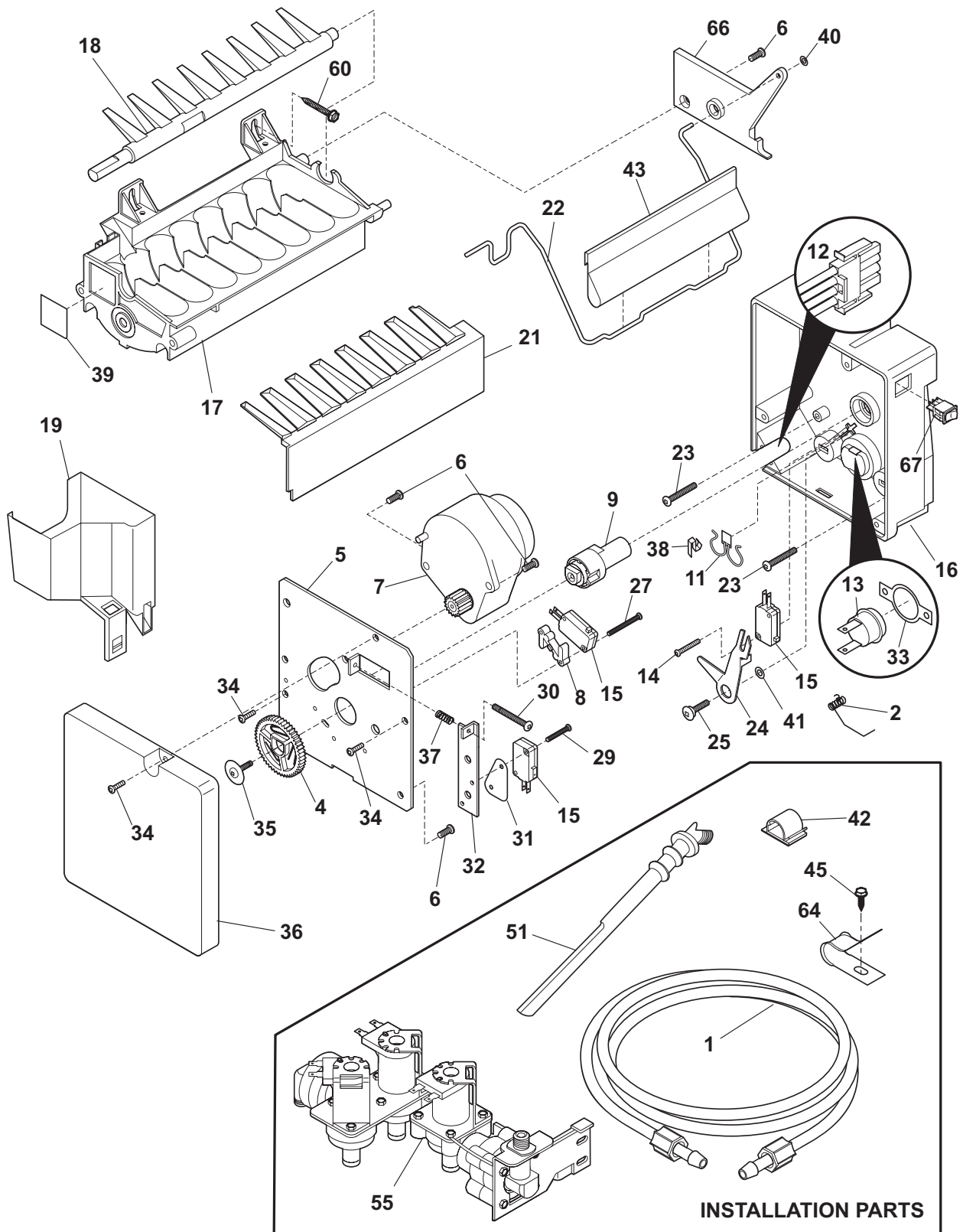

N58115TServo

ICE MAKER

Model Index: A FGHS2669K (FGHS2669KE0)
 B FGHS2669K (FGHS2669KP0)
 C FGHS2679K (FGHS2679KE0)
 D FGHS2679K (FGHS2679KP0)

POS. NO	PART NO.		DESCRIPTION
1	218976419	A B C D	Tube-water inlet, valve to door
1*	218976429	A B C D	Tube-water inlet, 97.50", brown/tan
1*	218976915	A B C D	Tube-water inlet, inlet valve, to filter
1*	240561703	A B C D	Seal-water inlet, inlet valve, to ice maker
2	5304436616	A B C D	Spring, torsion
4	5304458380	A B C D	Gear
5	5304458383	A B C D	Plate-mounting
6	5304458386	A B C D	Screw
7 #	5304458382	A B C D	Motor-ice maker Svo
8	5304458388	A B C D	Spacer-hold switch
9	5304456662	A B C D	Cam
11 #	5304458400	A B C D	Thermal Cutoff, ice maker
12	5304458379	A B C D	Harness-wiring
13	5304456665	A B C D	Thermostat, ice maker
14	5304458384	A B C D	Screw
15 #	5304456667	A B C D	Switch-micro, (3)
16	5304458395	A B C D	Housing, control
17	5304456669	A B C D	Mold-ice maker, w/therm cut off
18	5304458377	A B C D	Ejector-ice
18*	241522901	A B C D	Harness-wiring, icmkr/container
19	5304458378	A B C D	Cup-water inlet
21	5304458390	A B C D	Ice Stripper
22	5304458375	A B C D	Shut-off Arm
23	5304458394	A B C D	Screw
24	5304458391	A B C D	Lever Arm
25	5304456676	A B C D	Screw, M 4x12.8 #2, lever arm/sprt
27	5304458385	A B C D	Screw
29	5304458393	A B C D	Screw
30	5304458387	A B C D	Screw
31	5304458381	A B C D	Insulator
32	5304456681	A B C D	Plate-valve switch
33	5304456682	A B C D	Spring, timing adjust
34	5304455684	A B C D	Screw, plazscrew, 8-10 x 1/2, (3)
35	5304456684	A B C D	Screw
36	5304458376	A B C D	Cover-ice maker
37	5304408583	A B C D	Spring-timing adj
38	5304458398	A B C D	Clip
39	5304458399	A B C D	Conductor-heat
40	5304458401	A B C D	Clip-retainer
41	5304456689	A B C D	Washer, nylon
42	218515403	A B C D	Clip-grille
43	241720601	A B C D	Extension
45	5304455650	A B C D	Screw, hex washer head, 8-15A x 0.625, low profile
51	241796403	A B C D	Tube-water fill, extension
55 #	241734301	A B C D	Valve-water, triple solenoid
55*	218709101	A B C D	Screw, hex head, 10-32 x 0.500
55*	240363602	A B C D	Screw-shoulder

ICE MAKER

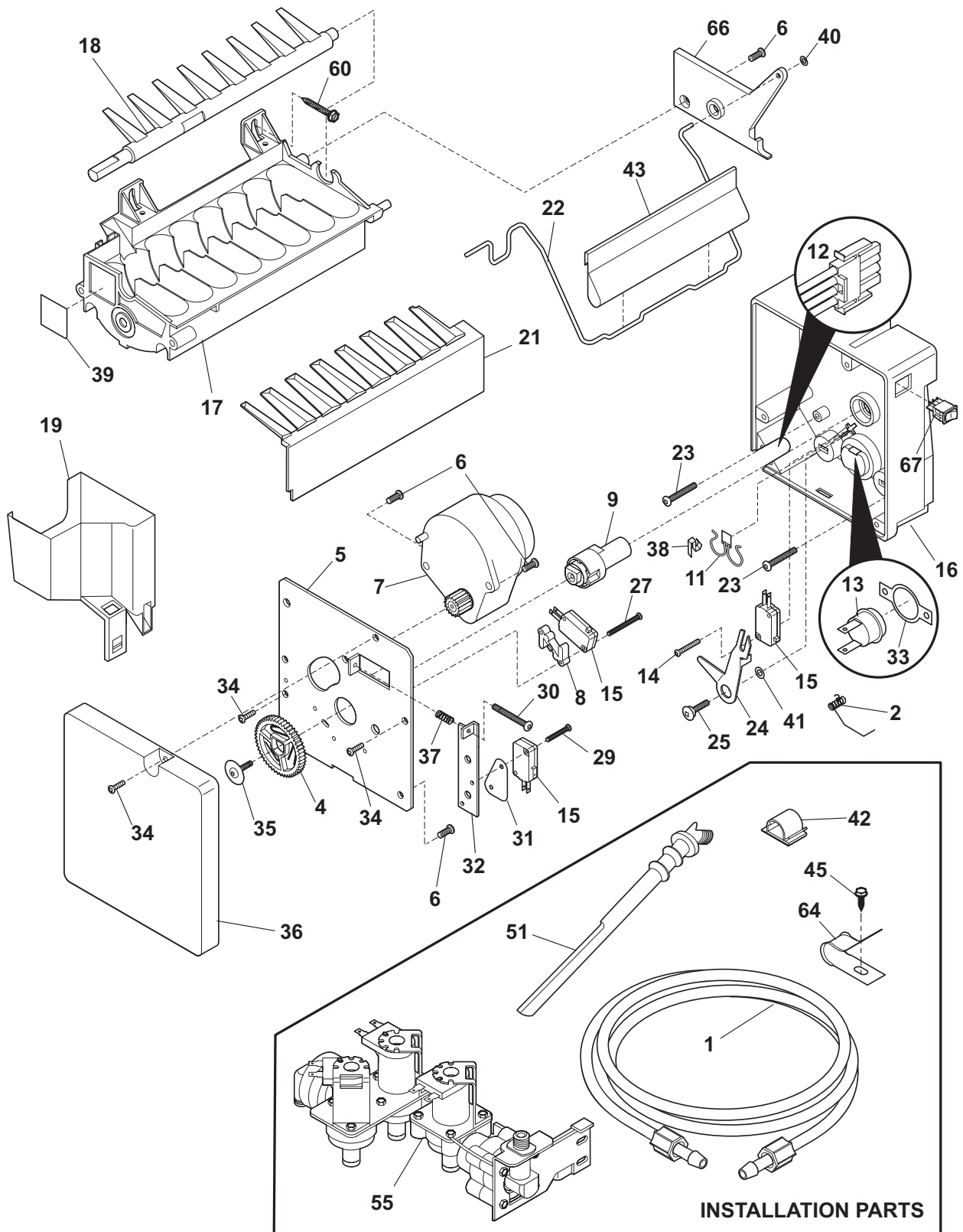

N58115TServo

ICE MAKER

Model Index: **A** FGHS2669K (FGHS2669KE0)
 B FGHS2669K (FGHS2669KP0)
 C FGHS2679K (FGHS2679KE0)
 D FGHS2679K (FGHS2679KP0)

POS. NO	PART NO.		DESCRIPTION
60	218362501	A B C D	Screw, hex washer head, 8-18AB x 1.250, spacer, (2)
64	5304455846	A B C D	Clamp, .31 ID, steel, water tube
66	5304458374	A B C D	Bracket-ice maker
67	5304458392	A B C D	Switch-on/off
*	240352102	A B C D	Connector-water, straight
*	241583301	A B C D	Deflector-air, ice maker
*	5304458389	A B C D	Screw
* #	241709801	A B C D	Ice Maker, radius cube, 115 V, no instl parts

WIRING SCHEMATIC

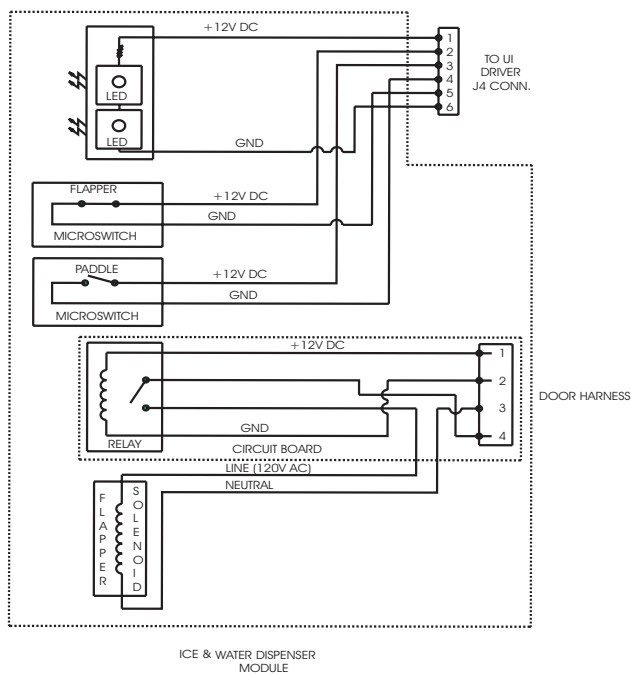
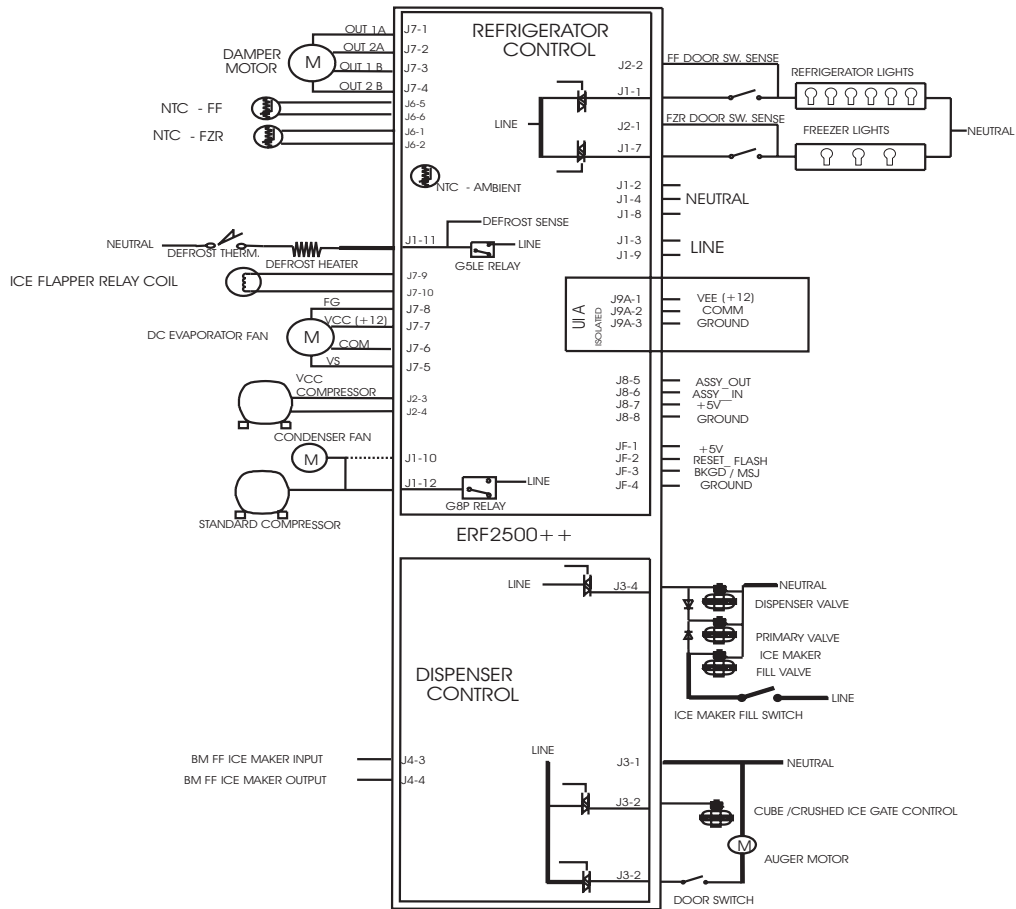

WIRING DIAGRAM

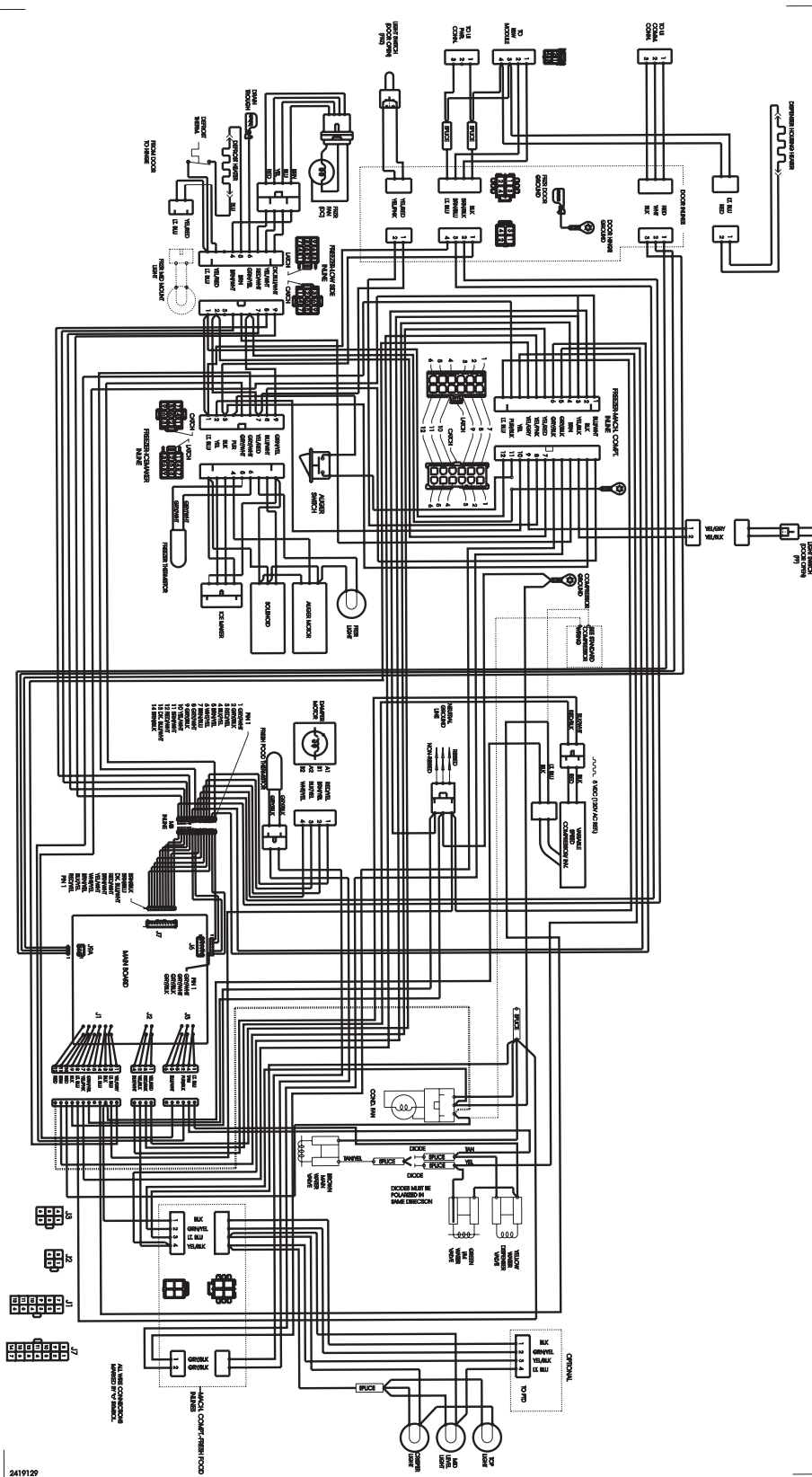

2419129