

USE AND CARE MANUAL

36 INCH REFRIGERATOR

2 AND 3 DOOR MODELS

For use with models: EF36BNNF, IF36BNNF, PF36BNNF

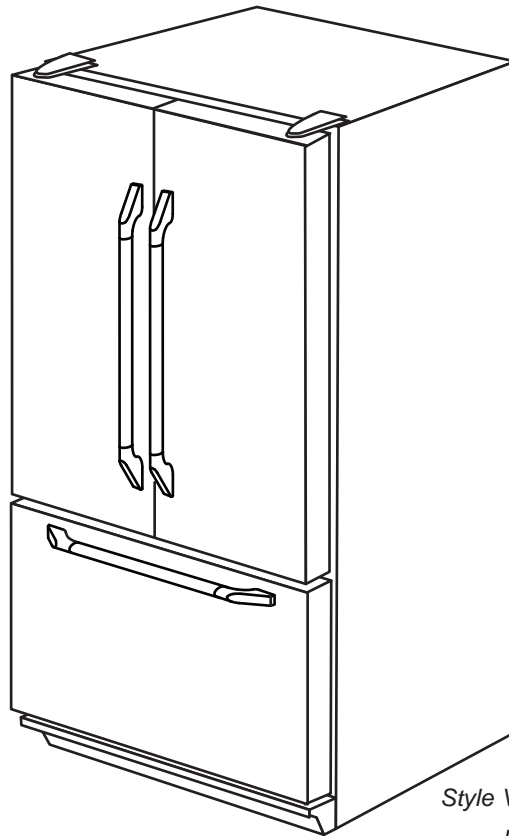

Style Varies

Model EF36BNNF Shown

Table of Contents

| | |
|-----------------------------------|------------|
| Refrigerator Safety | 1 |
| Important Information | 2 |
| Before Use | 2 |
| Refrigerator Operation | 2-10 |
| Care and Cleaning | 10-12 |
| Before You Call for Service | 13-14 |
| Warranty and Service | 15 |
| Notes | 16 |
| Francis | 17-36 |
| Warranty Card | Back Cover |



To Our Valued Customer:

Congratulations on your purchase of the very latest in Dacor® products! Our unique combination of features, style and performance make us The Life of the Kitchen™, and a great addition to your home.

In order to familiarize yourself with the controls, functions, and full potential of your new Distinctive Appliance, we suggest that you thoroughly read this use and care manual, beginning with the **Important Safety Instructions** section.

All Dacor appliances are designed and manufactured with quality and pride, while working within the framework of our company value. Should you ever experience a problem with your product, please first check the **Before You Call for Service** section of this manual for guidance. It provides useful suggestions and remedies prior to calling for service.

Valuable customer input helps us to continuously improve our products and services, so please feel free to contact our Customer Service Team for assistance with any of your product support needs.

Dacor Customer Service Team
1440 Bridge Gate Drive
Diamond Bar, CA 91765

Telephone: (800) 793-0093
Fax: (626) 403-3130
Hours of Operation: Monday through Friday
6:00 A.M. to 5:00 P.M. Pacific Time
Web Site: www.Dacor.com

Thank you for choosing Dacor for your home. We are a company built by families for families and we are dedicated to serving yours. We are confident that your new Dacor product will deliver a high level of performance and enjoyment for many years to come.

Sincerely,

The Dacor Customer Service Team

Refrigerator Safety

Your safety and the safety of others are very important.

We have provided many important safety messages in this manual and on your appliance. Always read and obey all safety messages.



This is the safety alert symbol.

This symbol alerts you to potential hazards that can kill or hurt you and others.

All safety messages will follow the safety alert symbol and either the word "DANGER" or "WARNING."

These words mean:

⚠ DANGER

You can be killed or seriously injured if you don't immediately follow instructions.

⚠ WARNING

You can be killed or seriously injured if you don't follow instructions.

All safety messages will tell you what the potential hazard is, tell you how to reduce the chance of injury, and tell you what can happen if the instructions are not followed.

IMPORTANT SAFETY INSTRUCTIONS

WARNING: To reduce the risk of fire, electric shock, or injury when using your refrigerator, follow these basic precautions:

- Plug into a grounded 3 prong outlet.
- Do not remove ground prong.
- Do not use an adapter.
- Do not use an extension cord.
- Disconnect power before servicing.
- Replace all parts and panels before operating.
- Remove doors from your old refrigerator.
- Use nonflammable cleaner.
- Keep flammable materials and vapors, such as gasoline, away from refrigerator.
- Use two or more people to move and install refrigerator.
- Disconnect power before installing ice maker (on ice maker kit ready models only).
- Use a sturdy glass when dispensing ice (on some models).

SAVE THESE INSTRUCTIONS

Proper Disposal of Your Refrigerator

⚠ WARNING

Suffocation Hazard

Remove doors from your old refrigerator.

Failure to do so can result in death or brain damage.

IMPORTANT: Child entrapment and suffocation are not problems of the past. Junked or abandoned refrigerators are still dangerous, even if they sit out for "just a few days." If you are getting rid of your old refrigerator, please follow the instructions below to help prevent accidents.

Before you throw away your old refrigerator or freezer:

- Take off the doors.
- Leave the shelves in place so children may not easily climb inside.

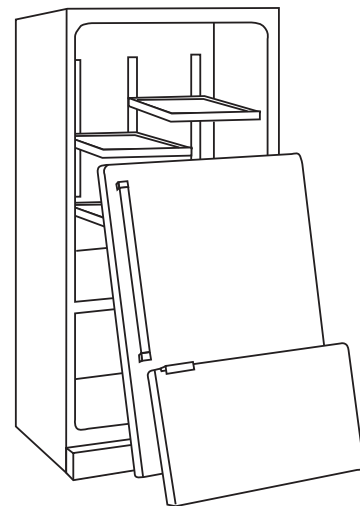

Important Information

Installer: Please leave this guide with this appliance.

Consumer: Please read and keep this use and care manual for future reference. This guide provides proper use and maintenance information. **Keep this guide and the sales receipt and/or cancelled check together for future reference. Proof of original purchase date is needed for warranty service.**

If you have any questions, call:

Dacor Customer Service

(800) 793-0093 (U.S.A. and Canada)

Monday — Friday 6:00 A.M. to 5:00 P.M. Pacific Time

Web site: www.Dacor.com

Have the complete model and serial number identification of your refrigerator ready. These numbers are found on a serial number label, located on the right side of the refrigerator liner. Record these numbers on this page for easy access.

Model Number _____

Serial Number _____

Date of Purchase _____

For warranty and service information, see page 15.

In our continuing effort to improve the quality and performance of our products, it may be necessary to make changes to the appliance without revising this guide.

IMPORTANT: If you receive a damaged product, immediately contact your dealer or builder. Do not install or use a damaged appliance.

Before Use

Remove the Packaging

- Remove tape and glue residue from surfaces before turning on the refrigerator. Rub a small amount of liquid dish soap over the adhesive with your fingers. Wipe with warm water and dry.
- Do not use sharp instruments, rubbing alcohol, flammable fluids or abrasive cleaners to remove tape or glue. These products can damage the surface of your refrigerator. For more information, see *Important Safety Instructions* on page 1.
- Dispose of/recycle all packaging materials.

Clean Before Using

After you remove all of the packaging materials, clean the inside of your refrigerator before using it. See the cleaning instructions in the *Care and Cleaning* section.

Important information to know about glass shelves and covers:

Do not clean glass shelves or covers with warm water when they are cold. Shelves and covers may break if exposed to sudden temperature changes or impact, such as bumping. Tempered glass is designed to shatter into many small, pebble-size pieces. This is normal. Glass shelves and covers are heavy. Use both hands when removing them to avoid dropping.

Refrigerator Operation

⚠ WARNING



Electrical Shock Hazard

- Plug into a grounded 3 prong outlet.
- Do not remove ground prong.
- Do not use an adapter.
- Do not use an extension cord.

Failure to follow these instructions can result in death, fire, or electrical shock.

⚠ WARNING



Explosion Hazard

Keep flammable materials and vapors, such as gasoline, away from refrigerator.

Failure to do so can result in death, explosion, or fire.

Plug the refrigerator into a grounded 3-prong electrical outlet.

Refrigerator Operation

Setting the Controls

The control panel is located at the top front of the fresh food compartment.

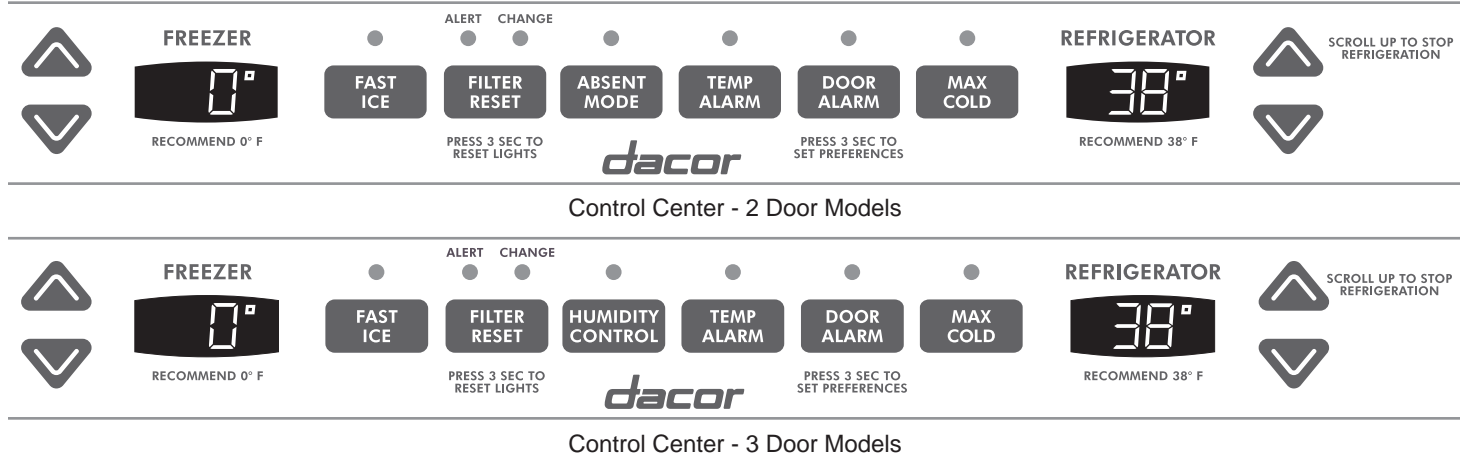

Initial Temperature Settings

Temperatures are preset at 38°F (3°C) in the fresh food compartment and 0°F (-18°C) in the freezer compartment. The display will show the average compartment temperatures, based on several measurement points within the compartment.

NOTE: Temperatures displayed may vary from set point due to door openings or during defrost. Thermometers placed in the refrigerator may record a temperature slightly above or below the displayed temperature. This is normal as the displayed temperature is an average.

Temperature Adjustments

- Allow the temperature to stabilize for 24 hours after loading the refrigerator before making any temperature adjustments.
- The first press of the up or down arrow key shows the current temperature set point.
- Subsequent pressing of the up key ▲ or the down key ▼ raises or lowers the temperature set point.
- The display will show the new set point for approximately three seconds, then return to the actual temperature currently within that compartment.
- Limit temperature changes to one degree at a time. Allow the new temperatures to stabilize for 24 hours before making a new temperature adjustment.

Fast Ice

When activated, fast ice reduces the freezer temperature to the optimum setting for 24 hours in order to produce more ice.

NOTE: When the fast ice feature is in operation, the up ▼ and down ▲ keys for the freezer control will not operate.

Door Alarm

Press the DOOR ALARM key to activate or deactivate the door alarm. The door alarm is active when the indicator above the DOOR ALARM key is lit.

The door alarm alerts you when one of the doors has been left open for five continuous minutes. An audible alarm will sound every few seconds until the door is closed, or the door alarm is deactivated.

Temp Alarm

The temperature alarm system will alert you if the freezer or fresh food temperatures exceed normal operating temperatures due to a power outage or other event. When activated, the TEMP ALARM light will illuminate.

If the freezer or fresh food temperatures have exceeded these limits, the display will alternately show the current compartment temperatures and the highest compartment temperatures reached when the power was out. An audible alarm will sound repeatedly.

Press the TEMP ALARM key once to stop the audible alarm. The TEMP ALARM light will continue to flash and the temperatures will alternate until the temperatures have stabilized.

To turn off the temperature alarm, press and hold the TEMP ALARM key for three seconds. The indicator light will go off.

Maximum Cold

When activated, maximum cold causes the fresh food and freezer temperatures to drop to the minimum settings on the control. This cools down the refrigerator and freezer after extended door openings or when loading the refrigerator or freezer with warm food.

NOTE: When the maximum cold feature is in operation, the up ▲ and down ▼ keys for the refrigerator and freezer controls will not operate.

To activate, press the MAX COLD key. Maximum cold will deactivate automatically after 12 hours, or press the MAX COLD key to deactivate manually.

Absent Mode/Humidity Control

The absent mode/humidity control feature causes the freezer to defrost less frequently, conserving energy. The ABSENT MODE/HUMIDITY CONTROL indicator light will illuminate when the feature is activated. To deactivate, press the ABSENT MODE/HUMIDITY CONTROL key again or open either door. The indicator light will go out.

NOTE : Door openings will not deactivate the absent mode/humidity control for approximately one hour after activation.

Refrigerator Operation

Setting the Controls (continued)

Reset Filter

When a water filter has been installed in the refrigerator, the yellow ALERT light will illuminate when 90 percent of the volume of water for which the filter is rated has passed through the filter or 11 months have elapsed since the filter has been installed.

The red CHANGE light will illuminate when the rated volume of water has passed through the filter or 12 months have elapsed since the filter was installed. A new filter should be installed immediately when the CHANGE light is illuminated.

After replacing the filter, press and hold the RESET FILTER key for three seconds. The ALERT and CHANGE lights will go off.

Do not use with water that is microbiologically unsafe or of unknown quality without adequate disinfection before or after the system. Systems certified for cyst reduction may be used on disinfected waters that may contain filterable cysts.

User Preferences

Access the user preferences menu to:

- Change the temperature display from °F to °C
- Enable or disable audible alarms
- Activate the Sabbath mode

To access the user preferences menu, press and hold the DOOR ALARM key for three seconds. When in the user preferences mode, a short title for the feature will appear in the freezer temperature display and the feature status will appear in the fresh food display.

- Use the freezer up ▲ and down ▼ keys to scroll through the preferences.
- When the desired preference is displayed, use the fresh food up ▲ and down ▼ keys to change the status.
- When changes are complete, press and hold the DOOR ALARM key for three seconds or close the fresh food door(s).

About the Temperature Display (F_C)

“F” indicates that the temperature is displayed in degrees Fahrenheit. “C” indicates that the temperature is displayed in degrees Celsius.

About Sabbath Mode (SAB)

When the Sabbath mode is on, all control lights and the night light are disabled until it is turned off. This feature does not disable the interior lights. Press any key on the control center to restore the control lights and turn Sabbath mode off.

Alarm (AL)

When alarm mode is off, all audible alarms will be disabled until the feature is turned on.

To Turn Your Refrigerator Off/On

- Press the freezer up key ▲ repeatedly until “OFF” appears in the freezer display. Allow a few seconds for the refrigerator to shut off. Neither compartment will cool.
- Press either the refrigerator or freezer up ▲ or down ▼ key to turn on the refrigerator.

**FILTER
RESET**

Warm Cabinet Surfaces

At times, the front of the refrigerator cabinet may be warm to the touch. This condition is normal and helps prevent moisture from condensing on the cabinet. This condition will be more noticeable when the refrigerator is first started, during hot weather and after excessive or lengthy door openings.

Refrigerator Compartment

Shelves

Important information to know about glass shelves and covers:

Do not clean glass shelves or covers with warm water when they are cold. Shelves and covers may break if exposed to sudden temperature changes or impact, such as bumping. Tempered glass is designed to shatter into many small, pebble-size pieces. This is normal. Glass shelves and covers are heavy. Use both hands when removing them to avoid dropping.

Your refrigerator has spill-proof glass shelves. The spill-proof shelves have a spill retainer edge which allows for easier clean up and are equipped with a slide out feature. To slide out, grasp the front of the shelf and pull forward. Push in the shelf to return to the original position.

To remove a shelf:

- Slightly tilt up the front and lift up the rear of the shelf, then pull the shelf straight out.

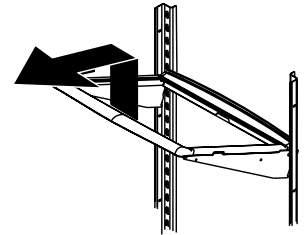

To lock the shelf into another position:

- Tilt up the front edge of the shelf.
- Insert the hook into the desired frame openings and let the shelf settle into place.
- Be sure the shelf is securely locked at the rear.

Door Storage

Dairy Center

The dairy center provides convenient door storage for spreadable items such as butter and margarine. This compartment can be moved to different locations to accommodate storage needs. To use the dairy center, raise the cover.

To remove:

- Raise the cover, pull upward and tilt out.

To install:

- Slide the dairy center in and down until firmly seated in the door liner.

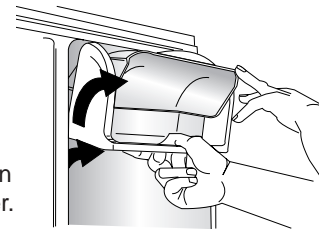

Door Buckets

Door buckets can be moved to meet storage needs.

To remove:

- Slide the bucket up and pull straight out.

To install:

- Slide the bucket in and down until firmly seated in the door liner.

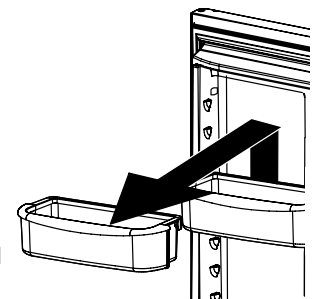

Refrigerator Operation

Crisper Drawers

The crisper drawers provide a higher humidity environment for fresh fruit and vegetable storage.

Controls

The crisper controls regulate the amount of humidity in the crisper drawer. Slide the control toward the FRUIT setting for produce with outer skins. Slide the control toward the VEGETABLES setting for leafy produce.



To remove:

- Pull the drawer out to full extension. Tilt up the front of the drawer and pull it straight out.

To install:

- Insert the drawer into the frame rails and push it back into place.

NOTE: For best results, keep the crisper drawers tightly closed.

Deli Drawer

The deli drawer is a full-width drawer with adjustable temperature control. This drawer can be used for large party trays, deli items, beverages or miscellaneous items. There is a divider to organize the drawer into sections if desired.

There is a temperature control which adjusts the amount of cold air allowed into the deli drawer. The control is located on the right of the drawer, under the lid.

Set the control to cold to provide a normal refrigerator temperature. Set the drawer on the coldest setting when a temperature colder than the main refrigerator compartment is desired. Use the coldest setting when storing meats.

NOTES:

- Cold air directed to the deli drawer can decrease refrigerator temperature. The refrigerator control may need to be adjusted.
- Do not place leafy vegetables in the deli drawer. Colder temperatures could damage leafy produce.

To remove:

- Lift the lid. Pull the drawer out to full extension. Tilt the drawer front up and pull it straight out.

To install:

- Push the metal glide rails to the back of the refrigerator. Place the drawer onto the rails and slide the drawer back until it falls into place.

To remove the divider:

- Pull the drawer completely out and raise the front of the divider to unhook it from the rear wall of the pantry. Lift it out.

To install the divider:

- Hook the back of divider over the rear wall of pantry and lower it into place.

Wine Trivet/Can Rack

The wine trivet/can rack accessory fits in the deli drawer or on a shelf.

Bottles or cans can be laid crosswise, or a single bottle may be laid in the center depression.

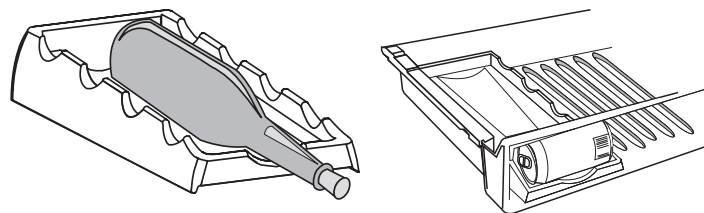

Deli Drawer Tray

The deli drawer tray allows for a removable tray within the full-width storage drawer.

Water Dispenser

The water dispenser is located on the left side wall of the fresh food section. It is designed for cold water dispensing only.

To dispense water:

- Hold a container under spout and press dispenser button.

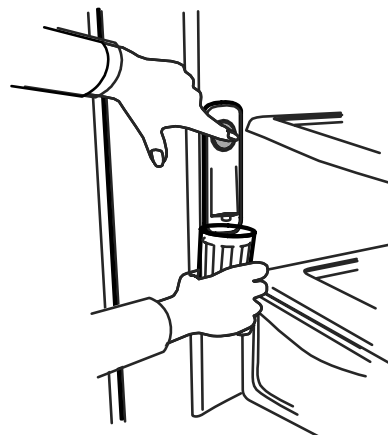

Fresh Food Storage

- The fresh food compartment of a refrigerator should be kept between 34°-40°F (1°-4°C) with an optimum temperature of 38°F (3°C). To check the temperature, place an appliance thermometer in a glass of water and place in the center of the refrigerator. Check after 24 hours. If the temperature is above 40°F (4°C) adjust the controls as explained on page 3.
- Avoid overcrowding the refrigerator shelves. This reduces the circulation of air around the food and results in uneven cooling.

Meat and Cheese

- Raw meat and poultry should be wrapped securely so leakage and contamination of other foods or surfaces does not occur.
- Occasionally mold will develop on the surface of hard cheeses (Swiss, Cheddar, Parmesan). Discard cheese that is moldy.

Dairy Food

- Most dairy foods such as milk, yogurt, sour cream and cottage cheese have freshness dates on their cartons for appropriate length of storage. Store these foods in the original carton and refrigerate immediately after purchasing and after each use.

Refrigerator Operation

Fresh Food Storage (continued)

Fruits and Vegetables

- Storage in the crisper drawers traps humidity to help preserve the fruit and vegetable quality for longer time periods (see page 5).
- Sort fruits and vegetables before storage and use bruised or soft items first. Discard those showing signs of decay.
- Always wrap odorous foods such as onions and cabbage so the odor does not transfer to other foods.
- While vegetables need a certain amount of humidity to remain fresh, too much humidity can shorten storage times (especially leafy vegetables). Drain vegetables well before storing.
- Wait to wash fresh produce until right before use.

Freezer Compartment

Ice Bin

The ice bin provides storage for ice.

To remove the ice bin:

- Pull it forward, away from the ice maker. To avoid the ice maker dumping ice while the bin is removed, turn the ice maker off by raising the ice maker arm.

To install the ice bin:

- Reverse the above procedure. Turn the ice maker on by lowering the ice maker arm.

Lower Basket Divider

The lower basket divider allows you to organize the basket area into sections.

To remove and replace the divider:

- Pull the divider straight up to remove it.
- To install it, hook the top corners of the divider over the top horizontal basket rungs.

Removing the Drawer Front

1. Pull the freezer drawer completely open.
2. Loosen the four screws attaching the drawer brackets to the drawer front as shown.

NOTE: Loosen the screws only three to four turns. Do not remove the screws from the drawer front.

3. Lift the drawer front upward and off the screws.

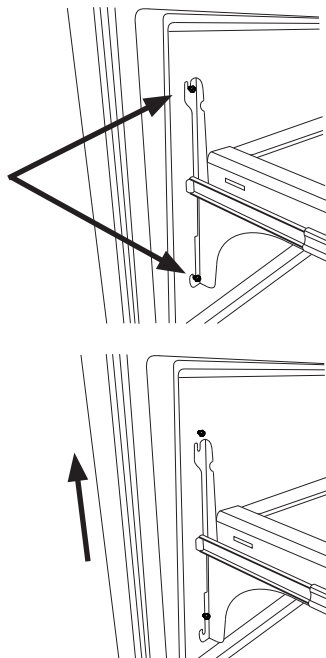

Reinstalling the Drawer Front

1. Slide the screws on the back of the drawer front into the slots in the drawer brackets on both sides. You may need to move the bottom of the bracket around slightly to get the slot to line up with the screw.
2. Tighten the four front panel screws completely. Do not over-tighten.
3. Place the freezer basket back into the drawer slides.

Automatic Ice Maker

Connect the ice maker to the water supply as instructed in the installation instructions. **Proper water flow and a level refrigerator are essential for optimal ice maker performance.**

Do not use with water that is microbiologically unsafe or of unknown quality without adequate disinfection before or after the system. Systems certified for cyst reduction may be used on disinfected waters that may contain filterable cysts.

To start the ice maker:

1. Make sure the ice bin is in place and the ice maker arm is down.
2. After the freezer section reaches between 0° to 2°F (-18° to -17° C), the ice maker fills with water and begins operating. You will have a complete harvest of ice approximately every three hours.
3. Allow approximately 24 hours after installation to receive the first harvest of ice.
4. Discard ice created within the first 12 hours of operation to assure the system is flushed of impurities.

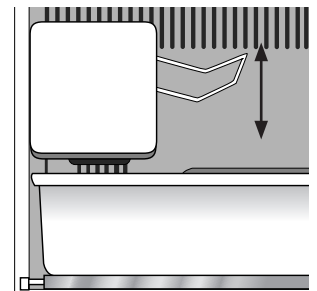

To turn off the ice maker:

- Raise the ice maker arm until a click is heard. The ice maker will remain in the off position until the arm is pushed down.

NOTES:

- The first one or two batches will probably contain undersized and irregular cubes because of air in the supply line.
- When the ice cubes are ejected, it is normal for several cubes to be joined together at the ends. They can easily be broken apart. The ice maker will continue to make ice until the supply of ice cubes raises the ice maker arm, shutting the ice maker off.
- Certain sounds may accompany the various cycles of the ice maker. The motor may have a slight hum, the cubes will rattle as they fall into an empty storage pan and the water valve may click or “buzz” occasionally.
- If the ice is not used frequently, the ice cubes will become cloudy, shrink, stick together and taste stale. Empty the ice storage bin periodically and wash it in lukewarm water. Be sure to dry the bin thoroughly before replacing it.
- Beverages and foods should not be placed in the ice storage bin for quick chilling. These items can block the ice maker arm, causing the ice maker to malfunction.
- Turn off the ice maker when the water supply is to be shut off for several hours.

Refrigerator Operation

Frozen Food Storage

- The freezer compartment of a refrigerator should be kept at approximately 0°F (-18°C). To check the temperature, place an appliance thermometer between the frozen packages and check after 24 hours. If the temperature is above 0°F (-18°C), adjust the control as described on page 3.
- A freezer operates more efficiently when it is at least two-thirds full.

Packaging foods for freezing

- To minimize dehydration and quality deterioration use aluminum foil, freezer wrap, freezer bags or airtight containers. Force as much air out of the packages as possible and be sure they are tightly sealed. Trapped air can cause the food to dry out, change color and develop an off-flavor (freezer burn).
- Wrap fresh meats and poultry with suitable freezer wrap prior to freezing.
- Do not refreeze meat that has completely thawed.

Loading the Freezer

- Avoid adding too much warm food to the freezer at one time. This overloads the freezer, slows the rate of freezing and can raise the temperature of frozen foods.
- Leave space between the packages so cold air can circulate freely, allowing food to freeze as quickly as possible.
- Avoid storing hard-to-freeze foods such as ice cream and orange juice on the freezer door shelves. These foods are best stored in the freezer interior where the temperature varies less with door openings.

Water Filter Removal and Installation

Do not use with water that is microbiologically unsafe or of unknown quality without adequate disinfection before or after the system. Systems certified for cyst reduction may be used on disinfected waters that may contain filterable cysts.

Initial Installation

The water filter is located in the upper right hand corner of the fresh food compartment.

1. Remove the blue bypass cap and retain it for later use.
2. Remove the sealing label from the end of the filter and insert it into the filter head.
3. Rotate it gently clockwise until it stops. Snap the filter cover closed.
4. Reduce water spurts by flushing air from the system. Run the water continuously for two minutes through the dispenser until the water runs steady. During initial use, allow about a one to two minute delay in water dispersal to allow the internal water tank to fill. Additional flushing may be required in some households where the water is of poor quality.

Replacing the Water Filter

IMPORTANT: Air trapped in the system may cause water and the cartridge to eject. Always dispense water for two minutes before removing the filter for any reason. Use caution when removing.

1. Turn the filter counterclockwise until it releases from the filter head.
2. Drain the water from the filter into the sink, and dispose of the filter in normal household trash.
3. Wipe up excess water in the filter cover and continue with *Initial Installation* steps 2 through 4.

Change the filter at least every 6 months.

IMPORTANT: The condition of the water and the amount used determines the life span of the water filter cartridge. If water use is high, or if water is of poor quality, replacement may need to take place more often.

To order visit www.everythingdacor.com or call Dacor Customer Service at (800) 793-0093. Use replacement cartridge AFF3.

The dispenser feature may be used without a water filter cartridge. If you choose this option, replace the filter with the blue bypass cap.

Refrigerator Operation

Water Filter Performance Data



System tested and certified by NSF International against NSF/ANSI Std 42 for the reduction of Chlorine Taste and Odor, Particulate Class I and against NSF/ANSI 53 for the reduction of Cysts, Turbidity, Asbestos, Mercury, Lead, Benzene, p-Dichlorobenzene, Carbofuran

| Standard No. 42: Aesthetic Effects | | | | | | | | |
|------------------------------------|-----------|----------------------------------|------------------|------------------|-------------|-------------|---------|-------------------------|
| Parameter | USEPA MCL | Influent Challenge Concentration | Influent Average | Effluent | | % Reduction | | Min. Required Reduction |
| | | | | Average | Maximum | Average | Minimum | |
| Chlorine | - | 2.0 mg/L ± 10% | 1.88 mg/L | <0.05136364 mg/L | 0.06 mg/L | >97.26 | 96.84 | 50% |
| Taste and Odor | - | - | - | - | - | - | - | - |
| Particulate** | - | at least 10,000 particles/ml | 5,700,000 #/ml | 30,583 #/ml | 69,000 #/ml | 99.52 | 98.94 | 85% |

| Standard No. 53: Health Effects | | | | | | | | |
|---------------------------------|-----------------|--|------------------|--------------|--------------|-------------|---------|-------------------------|
| Parameter | USEPA MCL | Influent Challenge Concentration | Influent Average | Effluent | | % Reduction | | Min. Required Reduction |
| | | | | Average | Maximum | Average | Minimum | |
| Turbidity | 1 NTU** | 11 ± 1 NTU*** | 10.7 NTU | 0.31 NTU | .049 NTU | 97.09 | 95.20 | 0.5 NTU |
| Cysts | 99.5% Reduction | Minimum 50,000/L | 166,500 #/L | <1 #/L | <1 #/L | >99.99 | >99.99 | >99.99% |
| Asbestos | 99% Reduction | 10 ⁷ 10 ⁸ fibers/L; fibers > micrometers in length | 155 MF/L | <1 MF/L | <1 MF/L | >99.99 | >99.99 | 99% |
| Lead at pH 6.5 | 0.015 mg/L | 0.15 mg/L +10% | 0.153 mg/L | <.001 mg/L | <.001 mg/L | >99.35 | >99.29 | 0.10 mg/L |
| Lead at pH 8.5 | 0.015 mg/L | 0.15 mg/L +10% | 0.150 mg/L | <.001 mg/L | <.001 mg/L | >99.33 | >99.29 | 0.10 mg/L |
| Mercury at pH 6.5 | 0.002 mg/L | .006 mg/L ± 10% | 0.006 mg/L | 0.0003 mg/L | 0.0005 mg/L | 95.70 | 90.91 | 0.002 mg/L |
| Mercury at pH 8.5 | 0.002 mg/L | .006 mg/L ± 10% | 0.006 mg/L | 0.0008 mg/L | 0.0015 mg/L | 86.22 | 75.93 | 0.002 mg/L |
| Atrazine | 0.003 mg/L | 0.009 mg/L + 10% | 0.009 mg/L | <0.002 mg/L | 0.002 mg/L | 76.99 | 75.31 | 0.003 mg/L |
| Benzene | 0.005 mg/L | 0.015 mg/L ± 10% | 0.014 mg/L | 0.0006 mg/L | 0.0011 mg/L | 95.71 | 92.14 | 0.005 mg/L |
| Carbofuran | 0.04 mg/L | 0.08 mg/L ± 10% | 0.081 mg/L | <0.001 mg/L | <0.001 mg/L | 98.74 | 98.46 | 0.04 mg/L |
| p-Dichlorobenzene | 0.075 mg/L | .225 mg/L ± 10% | 0.208 mg/L | <0.0005 mg/L | <0.0005 mg/L | 99.76 | 99.74 | 0.075 mg/L |
| Lindane | 0.0002 mg/L | 0.002 mg/L ± 10% | 0.002 mg/L | 0.000 mg/L | <0.0001 mg/L | 98.72 | 96.50 | 0.0002 mg/L |
| Toxaphene | 0.003 mg/L | 0.015 ± 10% | 0.015 mg/L | <0.001 mg/L | <0.001 mg/L | 92.97 | 91.67 | 0.003 mg/L |

* Tested using a flow rate of 0.78 gpm; pressure of 60 psig; pH of 7.5 + 0.5; temp. of 68° + 5°F (20° + 3°C)
 ** Measurement in particules/ml. Particules used were 0.5 - 1 microns
 *** NTU - Nephelometric Turbidity Units

Specifications

Rated Flow: .78 gpm (2.9 L/min)
 Min. Op. Temp: 33°F (.6°C)
 Max. Op. Temp: 100°F (38°C)
 Min. Op. Press: 35 psi (241 kPa)
 Max. Op. Press: 120 psi (827 kPa)

General Use Conditions

Read this *Performance Data Sheet* and compare the capabilities of this unit with your actual water treatment needs.

It is essential that operational, maintenance and filter replacement requirements be carried out for the product to perform as advertised.

Do not use with water that is microbiologically unsafe or of unknown quality without adequate disinfection before or after the system. Systems certified for cyst reduction may be used on disinfected waters that may contain filterable cysts.

This product is for cold water use only.

This system has been tested according to ANSI/NSF 42 and 53 for reduction of the substances listed above. The concentration of the indicated substances in water entering the system was reduced to a concentration less than or equal to the permissible limit for water leaving the system, as specified in ANSI/NSF 42 and 53.

State of California
 Department of Health Services
 Water Treatment Device
 Certificate Number

03 - 1583

Date Issued: September 16, 2003
 Date Revised: April 22, 2004

| Trademark/Model Designation | Replacement Elements |
|-----------------------------|----------------------|
| UKF8001AXX750 | UKF8001AXX |
| 469006-750 | 46 9006 |
| 67003523-750 | 67003523 |

Manufacturer: PentaPure Inc.

The water treatment device(s) listed on this certificate have met the testing requirements pursuant to Section 116830 of the Health and Safety Code for the following health related contaminants:

| Microbiological Contaminants and Turbidity | Inorganic/Radiological Contaminants |
|--|-------------------------------------|
| Cysts | Asbestos |
| Turbidity | Lead |
| | Mercury |
| Organic Contaminants | |
| Atrazine | |
| Lindane | |
| Benzene | |
| Carbofuran | |
| p-dichlorobenzene | |
| Toxaphene | |

Rated Service Capacity: 750 gal. Rated Service Flow: 0.78 gpm

Conditions of Certification:

Do not use where water is microbiologically unsafe or with water of unknown quality, except that systems certified for cyst reduction may be used on disinfected waters that may contain filterable cysts.

Refrigerator Operation

Normal Operating Sounds

Improvements in refrigeration design may produce sounds in your new refrigerator that are different or were not present in an older model. These improvements were made to create a refrigerator that is better at preserving food, is more energy efficient and is quieter overall. Because new refrigerators run quieter, sounds may be detected that were present in older refrigerators, but were masked by higher sound levels. Many of these sounds are normal. Please note that the surfaces adjacent to a refrigerator, such as hard walls, floors and cabinets may make these sounds seem even louder. The following are some of the normal sounds that may be noticed in a new refrigerator.

| Sound | Possible Cause | Solution |
|----------------------------------|--|---|
| Clicking | Motorized device (A) sounds like an electric clock and snaps in and out. | Normal operation |
| Air rushing or whirring | Freezer fan (B) and condenser fan (C) make this noise while operating. | Normal operation |
| Gurgling or boiling sound | Evaporator (D) and heat exchanger (E) refrigerant makes this noise when flowing. | Normal operation |
| Thumping | Ice cubes from ice maker drop into ice bucket (F) . | Normal operation |
| Vibrating noise | Compressor (G) makes a pulsating sound while running. | Normal operation |
| | Refrigerator is not level. | See installation instructions for details on how to level your refrigerator |
| Buzzing | Ice maker water valve (H) hookup buzzes when ice maker fills with water. | Normal operation |
| Humming | Ice maker (I) is in the on position without water connection. | Stop sound by raising the ice maker arm to the off position (see page 6). |
| | Compressor (G) can make a high-pitched hum while operating. | Normal operation |
| Hissing or popping | Defrost heater (K) hisses, sizzles or pops when operational. | Normal operation |

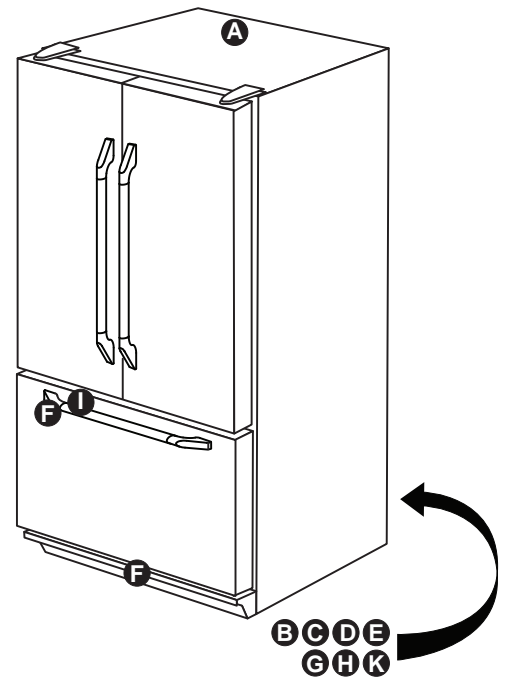

Energy Saving Tips

- Locate the refrigerator in the coolest part of the room. Avoid areas of direct sunlight, or near heating ducts, registers or other heat producing appliances. If this is not possible, isolate the exterior by using a section of cabinet or an added a layer of insulation.
- Avoid overcrowding the refrigerator shelves. Overcrowding reduces air circulation around food and causes the refrigerator to run longer.
- Avoid adding too much warm food to the refrigerator at one time. Doing so overloads the compartments and slows the rate of cooling.
- Do not use aluminum foil, wax paper or paper towels as shelf liners. Doing so decreases air flow and causes the refrigerator to run less efficiently.
- A freezer that is two-thirds full runs most efficiently.
- Clean the door gaskets every three months according to the cleaning instructions. Doing so will assure that the door seals properly and the refrigerator runs efficiently.
- Take time to organize items in the refrigerator to reduce the time that the door is open.
- Be sure your doors are closing securely by leveling the refrigerator as instructed in the installation instructions.
- Clean the condenser coils as indicated in the cleaning instructions every three months. Doing so will increase energy efficiency and cooling performance.

Refrigerator Operation

Accessories

| Description | Part Number |
|--|-------------|
| Vertical stainless steel panel trim kit for model PF36 | AFM36VSP |
| Epicure black chrome trim style handle kit for Dacor EF36 and PF36 2 door models | AFE36H2BC |
| Epicure black chrome trim style handle kit for Dacor EF36 and PF36 3 door models | AFE36H3BC |
| Epicure brass trim style handle kit for Dacor EF36 and PF36 2 door models | AFE36H2BR |
| Epicure brass trim style handle kit for Dacor EF36 and PF36 3 door models | AFE36H3BR |
| Epicure chrome trim style handle kit for Dacor EF36 and PF36 2 door models | AFE36H2CH |
| Epicure chrome trim style handle kit for Dacor EF36 and PF36 3 door models | AFE36H3CH |
| Epicure copper trim style handle kit for Dacor EF36 and PF36 2 door models | AFE36H2CP |
| Epicure copper trim style handle kit for Dacor EF36 and PF36 3 door models | AFE36H3CP |
| Millennia style handle kit for Dacor EF36 and PF36 2 door models | AFM36H2 |
| Millennia style handle kit for Dacor EF36 and PF36 3 door models | AFM36H3 |
| Preference style handle kit for Dacor EF36 and PF36 2 door models | AFP36H2 |
| Preference style handle kit for Dacor EF36 and PF36 3 door models | AFP36H3 |

The above accessories are available from your Dacor dealer or visit www.everythingdacor.com.

Care and Cleaning

Cleaning

⚠ WARNING



Explosion Hazard

Use nonflammable cleaner.

Failure to do so can result in death, explosion, or fire.

Important information to know about glass shelves and covers:

Do not clean glass shelves or covers with warm water when they are cold. Shelves and covers may break if exposed to sudden temperature changes or impact, such as bumping. Tempered glass is designed to shatter into many small, pebble-size pieces. This is normal. Glass shelves and covers are heavy. Use both hands when removing them to avoid dropping.

Both the refrigerator and freezer sections defrost automatically. However, clean both sections about once a month to avoid buildup of odors. Wipe up spills immediately.

IMPORTANT: Because air circulates between both sections, any odors formed in one section will transfer to the other. You must thoroughly clean both sections to eliminate odors. To avoid odor transfer and drying out of food, wrap or cover foods tightly.

To clean your refrigerator:

NOTE: Do not use abrasive or harsh cleaners such as window sprays, scouring cleansers, flammable fluids, cleaning waxes, concentrated detergents, bleaches or cleansers containing petroleum products on plastic parts, interior and door liners or gaskets. Do not use paper towels, scouring pads or other harsh cleaning tools.

1. Unplug the refrigerator or disconnect power.
2. Hand wash, rinse and dry removable parts and interior surfaces thoroughly. Use a clean sponge or soft cloth and a mild detergent in warm water.
3. Wash stainless steel and painted metal exteriors with a clean sponge or soft cloth and a mild detergent in warm water.

To keep stainless steel looking like new and to remove minor scuffs or marks, it is suggested that you use the Dacor approved stainless steel cleaner and polish, part number A302. To order the cleaner, see www.everythingdacor.com.

IMPORTANT: Do not allow the stainless steel cleaner and polish to come into contact with any plastic parts such as the trim pieces, dispenser covers or door gaskets. If unintentional contact does occur, clean plastic parts with a sponge and mild detergent in warm water. Dry thoroughly with a soft cloth.

4. There is no need for routine condenser cleaning in normal home operating environments. If the environment is particularly greasy or dusty, or there is significant pet traffic in the home, the condenser should be cleaned every 2 to 3 months to ensure maximum efficiency.

If you need to clean the condenser:

- Remove the base grille.
 - Use a vacuum cleaner with a soft brush to clean the grille, the open areas behind the grille and the front surface area of the condenser.
 - Replace the base grille when finished.
5. Plug in the refrigerator or reconnect power.

Care and Cleaning

Changing the Light Bulbs

NOTE: Not all appliance bulbs will fit your refrigerator. Be sure to replace the bulb with an appliance bulb of the same size, shape and wattage (no greater than 40 watts).

1. Unplug the refrigerator or disconnect power.
2. Remove the light shield.

Top of the refrigerator compartment:

Slide the light shield toward the back of the compartment to release it from the light assembly.

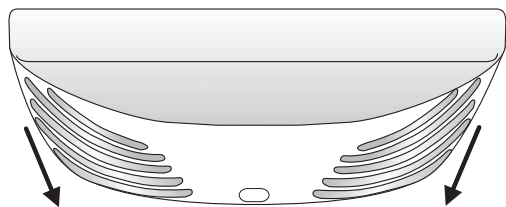

Top of freezer compartment:

The light shield opens from the back. Firmly press forward on the notches in the back of the shield and pull the shield down.

NOTE: You may need to remove the upper freezer shelf or basket to access the light assembly.

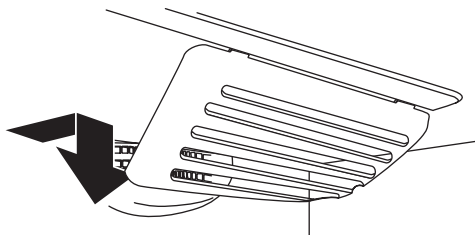

3. Replace the burned-out bulb(s) with an appliance bulb(s) no greater than 40 watts.
4. Replace the light shield.

Top of the refrigerator compartment:

Insert the tabs on the shield into the liner holes on each side of light assembly. Slide the shield toward the front until it locks into place.

NOTE: To avoid damaging the light shield, do not force the shield beyond the locking point.

Top of freezer compartment:

Insert the front tabs of the shield into the liner and snap the back portion of the shield over the light assembly.

5. Plug in the refrigerator or reconnect power.

Preparing for Vacation/Absence

⚠ WARNING



Tip Over Hazard

Refrigerator is top heavy and tips easily when not completely installed.

Keep doors taped closed until refrigerator is completely installed.

Use two or more people to move and install refrigerator.

Failure to do so can result in death or serious injury.

For short vacations/absences (three months or less):

1. Remove all perishables.
2. If no one will be checking in on the refrigerator during your absence, remove all frozen items also.
3. Shut off the water supply to the ice maker at least one day ahead of time.
4. After the last load of ice drops, raise the wire shut off arm to the off position.
5. Empty the ice bin.
6. If the room temperature will drop below 55°F (13°C), follow the instructions for longer absences.

For long vacations/absences (more than three months) or if the room temperature will drop below 55°F (13°C):

1. Remove the food.
2. Shut off the water supply to the ice maker at least one day ahead of time.
3. After the last load of ice drops, raise the wire shut off arm to the off position.
4. Empty the ice bin.
5. Remove the water filter cartridge and install the filter bypass. Dispose of the used cartridge.
6. Turn the freezer control to off.
7. Unplug the refrigerator.
8. Thoroughly clean the interior of both compartments with a baking soda solution and a clean soft cloth (four tablespoons of baking soda in one quart of warm water).
9. Dry thoroughly.
10. Leave the doors open to prevent the formation of mold and mildew.

Continued...

Care and Cleaning

Preparing for Vacation/Absence (Continued)

Upon Your Return

After a short vacation/absence:

1. Reconnect the water supply and turn on the supply valve.
2. Monitor the water connection for 24 hours and correct leaks if necessary.
3. Run 10-15 glasses of water from the dispenser to flush out the system.
4. Restart the ice maker by lowering the ice maker arm.
5. Discard at least the first three ice harvests.

After a long vacation/absence:

1. Reconnect the water supply and turn on the supply valve.
2. Plug the refrigerator back in and reset the controls (see page 3).
3. Monitor the water connection for 24 hours and correct leaks, if necessary.
4. Run water through the dispenser for at least three minutes with the filter bypass in place, then install the water filter (see page 7).
5. After installing the water filter, run water through the dispenser continuously for at least two minutes, or until water runs steady. Initially you may notice a one to two minute delay in water dispersal as the internal tank fills.
6. Restart the ice maker by lowering the ice maker arm.
7. Discard ice produced within the first 12 hours (at least the first three harvests).

Preparing to Move

⚠ WARNING



Tip Over Hazard

Refrigerator is top heavy and tips easily when not completely installed.

Keep doors taped closed until refrigerator is completely installed.

Use two or more people to move and install refrigerator.

Failure to do so can result in death or serious injury.

- Follow the instructions for long vacations/absences, through step 9.
- Secure all loose items such as shelves and drawers by taping them securely in place to prevent damage.
- Tape the doors shut.
- Use an appliance dolly when moving the refrigerator. Always truck the refrigerator from its side or back - never from its front.
- Be sure the refrigerator stays in an upright position during moving.

Before You Call for Service

Troubleshooting Guide

WARNING



Electrical Shock Hazard

Plug into a grounded 3 prong outlet.

Do not remove ground prong.

Do not use an adapter.

Do not use an extension cord.

Failure to follow these instructions can result in death, fire, or electrical shock.

Refrigerator will not operate

- **Power cord unplugged?** Plug into a grounded 3-prong outlet.
- **Is outlet working?** Plug in a lamp to see if the outlet is working.
- **Household fuse blown or circuit breaker tripped?** Replace the fuse or reset the circuit breaker. If the problem continues, call an electrician.
- **Are controls on?** Make sure the refrigerator controls are on. See page 3.
- **New installation?** Allow 24 hours following installation for the refrigerator to cool completely.

NOTE: Adjusting the temperature controls to the coldest setting will not cool either compartment more quickly.

Temperature is too warm

- **New installation?** Allow 24 hours following installation for the refrigerator to cool completely.
- **Door(s) opened often or left open?** Allows warm air to enter refrigerator. Minimize door openings and keep doors fully closed.
- **Large load of food added?** Allow several hours for refrigerator to return to normal temperature.
- **Controls set correctly for the surrounding conditions?** Adjust the controls a setting colder. Check temperature in 24 hours. See page 3.

There is interior moisture buildup

NOTE: Some moisture buildup is normal.

- **Humid room?** Contributes to moisture buildup.
- **Door(s) opened often or left open?** Allows humid air to enter refrigerator. Minimize door openings and keep doors fully closed.

The motor seems to run too much

Your new refrigerator may run longer than your old one due to its high-efficiency compressor and fans. The unit may run even longer if the room is warm, a large food load is added, doors are opened often or if the doors have been left open.

The refrigerator seems noisy

Refrigerator noise has been reduced over the years. Due to this reduction, you may hear intermittent noises from your new refrigerator that you did not notice from your old model. Below are listed some normal sounds with explanations.

- **Buzzing** - heard when the water valve opens to fill the ice maker.
- **Pulsating** - fans/compressor adjusting to optimize performance.
- **Hissing/Rattling** - flow of refrigerant, movement of water lines, or from items placed on top of the refrigerator.
- **Sizzling/Gurgling** - water dripping on the heater during defrost cycle.
- **Popping** - contraction/expansion of inside walls, especially during initial cool-down.
- **Water running** - may be heard when water melts during the defrost cycle and runs into the drain pan.
- **Creaking/Cracking** - occurs as ice is being ejected from the ice maker mold.

The doors will not close completely

- **Door blocked open?** Move food packages away from door.
- **Bin or shelf in the way?** Push bin or shelf back in the correct position.

The doors are difficult to open

- **Gaskets dirty or sticky?** Clean gaskets and contact surfaces with mild soap and warm water. Rinse and dry with soft cloth.

WARNING



Explosion Hazard

Use nonflammable cleaner.

Failure to do so can result in death, explosion, or fire.

Before You Call for Service

The ice maker is not producing ice or not enough ice

- **Refrigerator connected to a water supply and the supply shutoff valve turned on?** Connect refrigerator to water supply and turn water shutoff valve fully open.
- **Kink in the water source line?** A kink in the line can reduce water flow. Straighten the water source line.
- **Ice maker turned on?** Make sure wire shutoff arm or switch (depending on model) is in the on position.
- **New installation?** Wait 24 hours after ice maker installation for ice production to begin. Wait 72 hours for full ice production.
- **Freezer door closed completely?** Firmly close the freezer compartment door. If the freezer compartment door will not close all the way, see *The doors will not close completely*.
- **Large amount of ice recently removed?** Allow 24 hours for ice maker to produce more ice.
- **Ice cube jammed in the ice maker ejector arm?** Remove ice from the ejector arm with a plastic utensil.
- **Water filter installed on the refrigerator?** Remove filter and operate ice maker. If ice volume improves, then the filter may be clogged or incorrectly installed. Replace filter or reinstall it correctly.
- **Reverse osmosis water filtration system connected to your cold water supply?** This can decrease water pressure. See the installation instructions.

The ice cubes are hollow or small

NOTE: This is an indication of low water pressure.

- **Water shutoff valve not fully open?** Turn the water shut off valve fully open.
- **Kink in the water source line?** A kink in the line can reduce water flow. Straighten the water source line.
- **Water filter installed on the refrigerator?** Remove filter and operate ice maker. If ice quality improves, then the filter may be clogged or incorrectly installed. Replace filter or reinstall it correctly.
- **Reverse osmosis water filtration system connected to your cold water supply?** This can decrease water pressure. See installation instructions.
- **Questions remain regarding water pressure?** Call a licensed, qualified plumber.

Off-taste, odor or gray color in the ice

- **New plumbing connections?** New plumbing connections can cause discolored or off-flavored ice.
- **Ice stored too long?** Discard ice. Wash ice bin. Allow 24 hours for ice maker to make new ice.
- **Odor transfer from food?** Use airtight, moisture proof packaging to store food.
- **Are there minerals (such as sulfur) in the water?** A water filter may need to be installed to remove the minerals.
- **Water filter installed on the refrigerator?** Gray or dark discoloration in ice indicates that the water filtration system needs additional flushing. Flush the water system before using a new water filter. Replace water filter when indicated. See page 3.

The water dispenser will not operate properly

- **Refrigerator connected to a water supply and the supply shutoff valve turned on?** Connect refrigerator to water supply and turn water shutoff valve fully open.
- **Kink in the water source line?** Straighten the water source line.
- **New installation?** Flush and fill the water system. See the installation instructions.
- **Is the water pressure at least 35 psi (241 kPa)?** The water pressure to the home determines the flow from the dispenser. See the installation instructions.
- **Water filter installed on the refrigerator?** Remove filter and operate dispenser. If water flow increases, the filter may be clogged or incorrectly installed. Replace filter or reinstall it correctly.
- **Refrigerator door closed completely?** Close the door firmly. If it does not close completely, see *The doors will not close completely*.
- **Recently removed the doors?** Make sure the water dispenser wire/tube assembly has been properly reconnected. See the installation instructions.
- **Reverse osmosis water filtration system connected to your cold water supply?** This can decrease water pressure. See the installation instructions.

Water is leaking from the dispenser system

NOTE: One or two drops of water after dispensing is normal.

- **Glass not being held under the dispenser long enough?** Hold the glass under the dispenser 2 to 3 seconds after releasing the dispenser lever.
- **New installation?** Flush the water system. See the installation instructions.
- **Recently changed water filter?** Flush the water system. See the installation instructions.
- **Water on the floor near the base grille?** Make sure the water dispenser tube connections are fully tightened. See the installation instructions.

Water from the dispenser is warm

NOTE: Water from the dispenser is only chilled to 50°F (10°C).

- **New installation?** Allow 24 hours after installation for the water supply to cool completely.
- **Recently dispensed large amount of water?** Allow 24 hours for water supply to cool completely.
- **Water not been recently dispensed?** The first glass of water may not be cool. Discard the first glass of water.
- **Refrigerator connected to a cold water pipe?** Make sure the refrigerator is connected to a cold water pipe. See the installation instructions.

Warranty and Service

Product Maintenance

Do not perform any maintenance other than that instructed in the *Care and Cleaning* section of this manual. A qualified service technician should perform all other service.

Getting Help

Before you obtain service, please review the *Before You Call for Service* section of this manual. If you have performed the checks in the *Troubleshooting* section and the problem has not yet been remedied, please visit our web site or contact the Dacor Customer Service Team for a listing of Dacor authorized service agents. Before requesting service, become familiar with the warranty terms and conditions on this page.

Contact us through our web site at:

www.Dacor.com

Dacor Customer Service:

Tel: (800) 793-0093

Fax: (626) 403-3130

Business Hours: 6:00 a.m. - 5:00 p.m. Pacific Time

You may also write us at:

Dacor Customer Service
1440 Bridge Gate Drive
Diamond Bar, CA 91765

At Dacor, we believe that our quality of service equals that of our product. Should your experience with our service network or product be different, please contact our customer service team and share your encounter with us. We will do our utmost to resolve the situation for you and deliver on our Dacor promise. If you need anything clarified, just let us know.

What is Covered

**CERTIFICATE OF WARRANTIES DACOR REFRIGERATORS
WITHIN THE FIFTY STATES OF THE U.S.A., THE DISTRICT OF
COLUMBIA AND CANADA*:**

FULL ONE YEAR WARRANTY

One (1) year - From the date of original retail purchase, any part that fails in normal home use will be repaired or replaced free of charge. Ice Maker - When purchased with the refrigerator and installed by the dealer the ice maker will be considered part of the refrigerator for warranty purposes.

LIMITED WARRANTY

AquaClean Water Filter:

30 days - From the original retail purchase date, any part of the water filter cartridge which fails due to a defect in workmanship or materials will be replaced free of charge.

NOTE: The full warranty and the limited warranties apply when the refrigerator is located in the United States or Canada. Refrigerators located elsewhere are covered by the limited warranties only including parts that fail during the first year.

LIMITATIONS OF LIABILITY

The warrantor shall not be liable for any incidental or consequential damages, including food loss. Some states do not allow the exclusion or limitation of consequential damages, so the above limitation or exclusion may not apply to you.

*Warranty is null and void if non-CSA approved product is transported from the U.S.

What is Not Covered

1. Conditions and damages resulting from any of the following:
 - Improper installation, delivery or maintenance
 - Any repair, modification, alteration or adjustment not authorized by the manufacturer or an authorized servicer
 - Misuse, abuse, accidents or unreasonable use
 - Incorrect electric current, voltage or supply
 - Improper setting of any control
2. Warranties are void if the original serial numbers have been removed, altered or cannot be readily determined.
3. Light bulbs.
4. Products purchased for commercial or industrial use.
5. The cost of service or service call to:
 - Correct installation errors
 - Instruct the user on the proper use of the product. Transport the appliance to the servicer
6. Consequential or incidental damages sustained by any person as a result of any breach of these warranties. Some states do not allow the exclusion or limitation of consequential or incidental damages, so the above exclusion may not apply.

Notes

fold here



NO POSTAGE
NECESSARY
IF MAILED
IN THE
UNITED STATES

BUSINESS REPLY MAIL
FIRST-CLASS MAIL PERMIT NO. 4507 DIAMOND BAR CA

POSTAGE WILL BE PAID BY ADDRESSEE

DACOR INC.
ATTN: WARRANTY PROCESSING DEPT
1440 BRIDGE GATE DR STE 200
PO BOX 6532
DIAMOND BAR CA 91765-9861

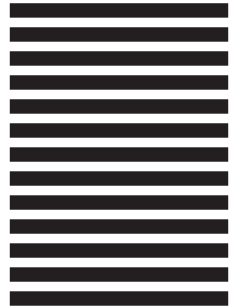



Please visit www.Dacor.com to activate your warranty online.

WARRANTY INFORMATION



IMPORTANT:

Your warranty will not be activated until you activate it online or return this form to Dacor. If you have purchased more than one Dacor product, please return all forms in one envelope or activate the warranty for each product online.

Please rest assured that under no conditions will Dacor sell your name or any of the information on this form for mailing list purposes. We are very grateful that you have chosen Dacor products for your home and do not consider the sale of such information to be a proper way of expressing our gratitude!

Owner's Name: _____
Last (Please Print or Type) First Middle

Street: _____

City: _____ State: _____ Zip: _____

Purchase Date: _____ Email: _____ Telephone: _____

Dealer: _____

City: _____ State: _____ Zip: _____

Your willingness to take a few seconds to fill in the section below will be sincerely appreciated. Thank you.

1. How were you **first** exposed to Dacor products? (Please check one only.)

- A. T.V. Cooking Show
- B. Magazine
- C. Appliance Dealer Showroom
- D. Kitchen Dealer Showroom
- E. Home Show
- F. Builder
- G. Architect/Designer
- H. Another Dacor Owner
- I. Model Home
- J. Other _____

2. Where did you buy your Dacor appliances?

- A. Appliance Dealer
- B. Kitchen Dealer
- C. Builder Supplier
- D. Builder
- E. Other _____

3. For what purpose was the product purchased?

- A. Replacement *only*
- B. Part of a Remodel
- C. New Home
- D. Other _____

4. What is your household income?

- A. Under \$75,000
- B. \$75,000 – \$100,000
- C. \$100,000 – \$150,000
- D. \$150,000 – \$200,000
- E. \$200,000 – \$250,000
- F. Over \$250,000

5. What other brands of appliances do you have in your kitchen?

- A. Cooktop _____
- B. Oven _____
- C. Dishwasher _____
- D. Refrigerator _____

6. Would you buy or recommend another Dacor product?

- Yes
- No

Comments: _____

Thank you very much for your assistance. The information you have provided will be extremely valuable in helping us plan for the future and giving you the support you deserve.

cut here

cut here