

Installation Instructions

Outdoor Grill Cart

Covers Models OBC36, OBC52, OBCW52



WARNING:

1. Since the cart and the grill are heavy, this installation process should be accomplished by a minimum of two people. Remove all individual components to lighten the grill before installation. Remove the cart from the shipping pallet before installation.
2. Sheet metal edges can be dangerous in heavy lifting situations. Please wear gloves during installation.
3. Attach the appliance to the cart with all of the supplied bolts before use.
4. Read the use and care manual completely before operation.



NOTES:

1. The Dacor cart ships assembled ready for installation of the outdoor grill.
2. All gas and electrical connections should be made after the grill is installed and bolted to the cart.
3. Your cart is prepared for either natural gas or liquid propane (LP) gas connections. However, it is important to verify that your outdoor grill was ordered correctly. If you will be utilizing LP gas, your grill must indicate LP in the model number. Do not proceed with installation if the model is not correct. Field conversion from one gas type to another is not permissible.

ASSEMBLY:

1. Remove the cart from the shipping carton and pallet.
2. Set the cart in an open location and lock the wheels on the cart to minimize potential movement.
3. Remove the drawers.
4. Remove the outdoor grill from its shipping carton and pallet. Remove the parts box to lighten the appliance.
5. As you place the outdoor grill on the cart, feed the gas line and electrical cord into the utility cut-out on the cart.
6. Center the unit on the cart, making sure to line up the threaded mounting holes under the bottom of the grill with the holes in the top of the cart.
7. Thread all of the supplied bolts into the bottom of the outdoor grill from inside the cart. Tighten the bolts into place.
8. Install the side shelves if desired. See next page.
9. Before installing the front drawers and tank shelf, connect the regulator and gas supply line according to the Outdoor Grill Installation Instructions.



WARNING:

- To avoid an explosion hazard, do not connect the cart or appliance(s) to electrical power until after the gas supply system has been checked for leaks.

10. Install the drawers. Put the LP tank on the tank shelf and connect it, if applicable.



CAUTION:

- The largest recommended LP tank size for the rollout tank shelf is five gallons.

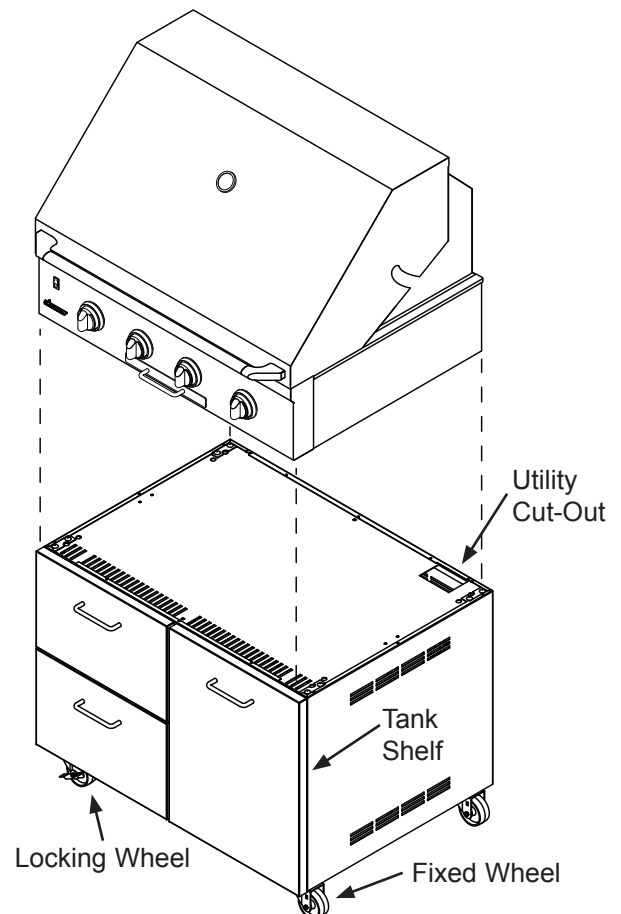

continued...

11. Turn on the gas and check for leaks according to the Outdoor Grill Installation Instructions.



WARNING:

The grill cart is equipped with a grounded three-wire electrical system and ground fault interrupter (GFI) electrical outlets for safety. To avoid an electric shock hazard:

- Connect the power cords from the outdoor grill, rotisserie motor and optional warming oven only to the electrical outlets mounted on the cart.
 - Do not under any circumstances:
 - Cut or remove the third (ground) prong from the appliance(s) and rotisserie power cords.
 - Do not use an adapter plug.
 - Do not use an extension cord.
 - Do not use a power cord that is frayed or damaged.
12. Connect a three-prong extension cord (minimum 5 Amp. capacity) to the power input on the back of the cart. Connect the extension cord to a grounded, three-prong, electrical outlet.
 13. With the tank shelf open, connect the power cord from the outdoor grill and the warming oven (if equipped with one) to the electrical outlet on the back panel inside the cart.
 14. Connect the rotisserie motor power cord to the electrical outlet on the back side of the cart.

SIDE SHELF INSTALLATION:

1. Install the front mounting bracket for the right side shelf. Use two (2) of the provided button head fasteners and two (2) lock washers. Tighten into place using a 5/32" allen wrench.

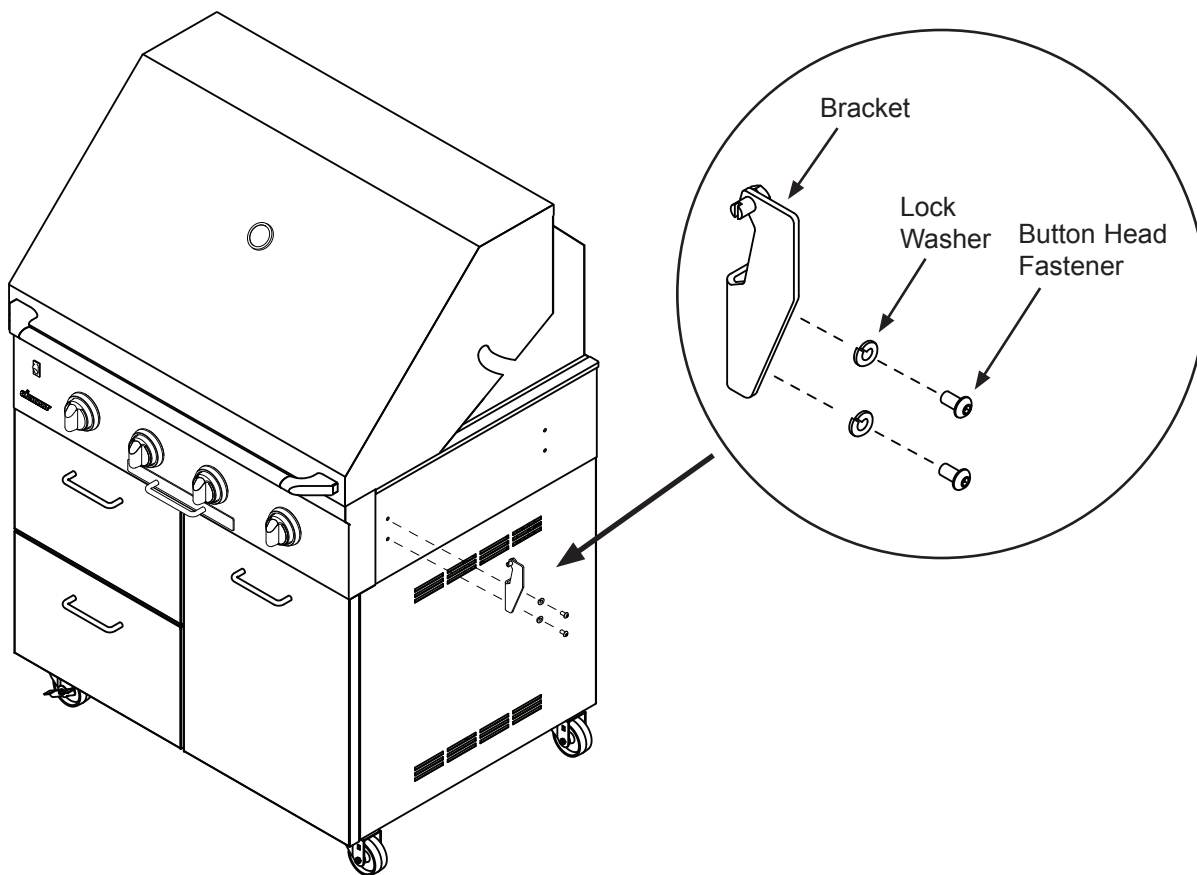

- Slide the slot on the inside of the shelf over the pin on the mounting bracket.

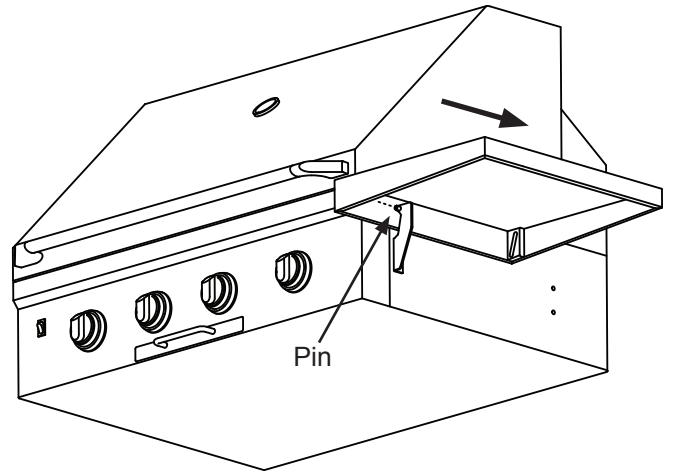

- While holding the shelf in place, insert the pin on the back mounting bracket into the slot on the back side of the shelf.

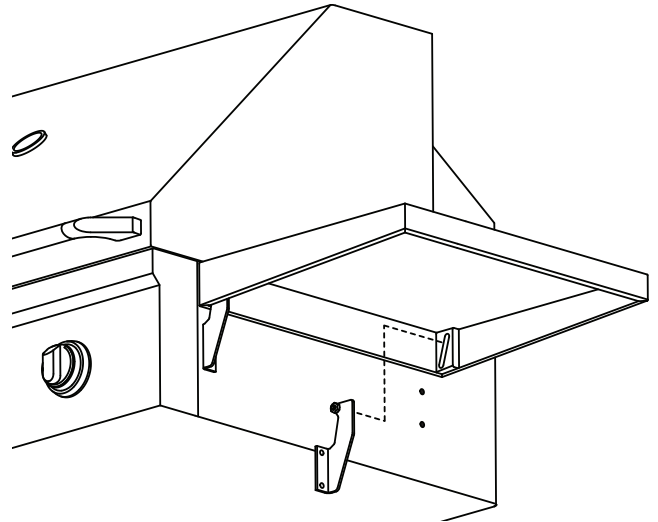

- While holding the shelf and back mounting bracket in place, attach the back mounting bracket using two (2) of the provided button head fasteners and two (2) lock washers.
- Repeat steps 1 through 4 for the left side shelf.

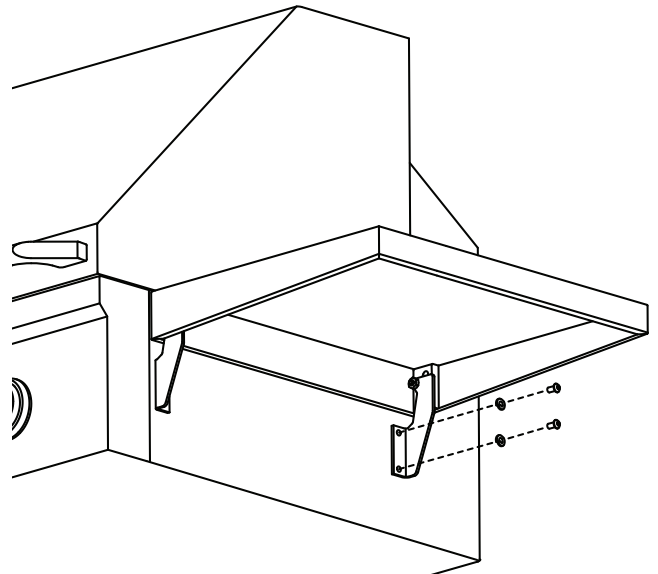

NOTE: Dacor offers a protective grill cover and a grill/cart cover. For more information concerning these options, contact your Dacor appliance dealer.

