

Friedrich

Service & Parts Manual

WallMaster® Thru-the-Wall

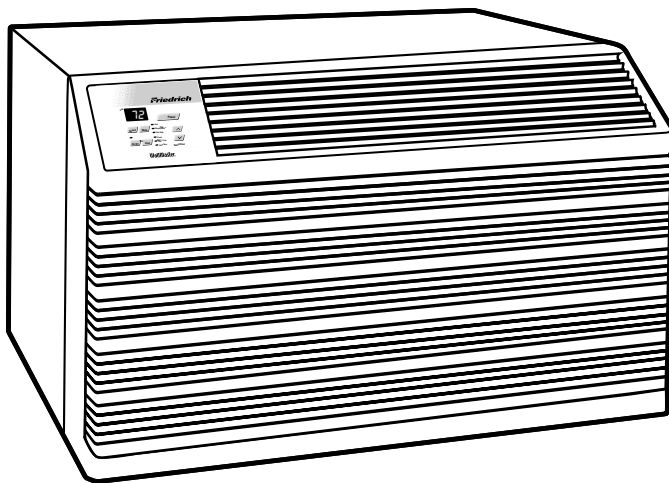

WS08B10A-C
WS10B10A-C
WS14B10A-C
WS10B30A-C
WS13B30B-C
WS16B30A-C
WE10B33A-B
WE13B33B-B
WE16B33A-B
WY10B33A-B
WY13B33A-B

TABLE OF CONTENTS

Warranty	3
Routine Maintenance	4
Unit Identification	5
Performance Data	6
Electrical Data	7
Functional Component Definitions	8
Electronic Controls	9
Rotary Controls	10
Refrigeration Sequence of Operation	11
Sealed Refrigeration Repairs	12-13
Refrigerant Charging	13
General Troubleshooting	14-20
Wiring Diagrams	21-25
Parts Diagram	26
Parts Lists	27-29



Friedrich Air Conditioning Company
P.O. Box 1540
San Antonio, TX 78295
210.357.4400
www.friedrich.com

WALLMASTER[®] THRU-THE-WALL AIR CONDITIONERS LIMITED WARRANTY

FIRST YEAR

ANY PART: If any part supplied by FRIEDRICH fails because of a defect in workmanship or material within twelve months from date of original purchase, FRIEDRICH will repair the product at no charge, provided room air conditioner is reasonably accessible for service. Any additional labor cost for removing inaccessible units and/or charges for mileage related to travel by a Service Agency that exceeds 25 miles one way will be the responsibility of the owner. This remedy is expressly agreed to be the exclusive remedy within twelve months from the date of the original purchase.

SECOND THROUGH FIFTH YEAR

SEALED REFRIGERANT SYSTEM: If the Sealed Refrigeration System (defined for this purpose as the compressor, condenser coil, evaporator coil, reversing valve, check valve, capillary, filter drier, and all interconnecting tubing) supplied by FRIEDRICH in your Room Air Conditioner fails because of a defect in workmanship or material within sixty months from date of purchase, FRIEDRICH will pay a labor allowance and parts necessary to repair the Sealed Refrigeration System; **PROVIDED** FRIEDRICH will not pay the cost of diagnosis of the problem, removal, freight charges, and transportation of the air conditioner to and from the Service Agency, and the reinstallation charges associated with repair of the Sealed Refrigeration System. All such cost will be the sole responsibility of the owner. This remedy is expressly agreed to be the exclusive remedy within sixty months from the date of the original purchase.

APPLICABILITY AND LIMITATIONS: This warranty is applicable only to units retained within the Fifty States of the U.S.A., District of Columbia, and Canada. This warranty is not applicable to:

1. Air filters or fuses.
2. Products on which the model and serial numbers have been removed.
3. Products which have defects or damage which results from improper installation, wiring, electrical current characteristics, or maintenance; or caused by accident, misuse or abuse, fire, flood, alterations and/or misapplication of the product and/or units installed in a corrosive atmosphere, default or delay in performance caused by war, government restrictions or restraints, strikes, material shortages beyond the control of FRIEDRICH, or acts of God.

OBTAINING WARRANTY PERFORMANCE: Service will be provided by the **FRIEDRICH Authorized Dealer or Service Organization** in your area. They are listed in the Yellow Pages. If assistance is required in obtaining warranty performance, write to: Room Air Conditioner Service Manager, Friedrich Air Conditioning Co., P.O. Box 1540, San Antonio, TX 78295-1540.

LIMITATIONS: THIS WARRANTY IS GIVEN IN LIEU OF ALL OTHER WARRANTIES. Anything in the warranty notwithstanding, ANY IMPLIED WARRANTIES OF FITNESS FOR PARTICULAR PURPOSE AND/OR MERCHANTABILITY SHALL BE LIMITED TO THE DURATION OF THIS EXPRESS WARRANTY. MANUFACTURER EXPRESSLY DISCLAIMS AND EXCLUDES ANY LIABILITY FOR CONSEQUENTIAL OR INCIDENTAL DAMAGE FOR BREACH OF ANY EXPRESSED OR IMPLIED WARRANTY.

NOTE: Some states do not allow limitations on how long an implied warranty lasts, or do not allow the limitation or exclusion of consequential or incidental damages, so the foregoing exclusions and limitations may not apply to you.

OTHER: This warranty gives you specific legal rights, and you may also have other rights which vary from state to state.

PROOF OF PURCHASE: Owner must provide proof of purchase in order to receive any warranty related services.

All service calls for explaining the operation of this product will be the sole responsibility of the consumer.

All warranty service must be provided by an **Authorized FRIEDRICH Service Agency**, unless authorized by FRIEDRICH prior to repairs being made.

(10-04)

ROUTINE MAINTENANCE

NOTE: Units are to be inspected and serviced by qualified service personnel only.

Routine maintenance is required annually or semi-annually, depending upon annual usage.

1. Clean the unit air intake filter at least every 250 to 300 fan hours of operation or when the unit's indicator light is on if so equipped. Clean the filters with a mild detergent in warm water and allow to dry thoroughly before reinstalling.
2. The indoor coil (evaporator coil), the outdoor coil (condenser coil) and base pan should be inspected periodically (yearly or bi-yearly) and cleaned of all debris (lint, dirt, leaves, paper, etc.). Clean the coils and base pan with a soft brush and compressed air or vacuum. If using a pressure washer, be careful not to bend the aluminium fin pack. Use a sweeping up and down motion in the direction of the vertical aluminum fin pack when pressure cleaning coils. Cover all electrical components to protect them from water or spray. Allow the unit to dry thoroughly before reinstalling it in the sleeve.

NOTE: Do not use a caustic coil cleaning agent on coils or base pan. Use a biodegradable cleaning agent and degreaser.

Inspect the indoor blower housing, evaporator blade, condenser fan blade, and condenser shroud periodically (yearly or bi-yearly) and clean of all debris (lint, dirt, mold, fungus, etc.) Clean the blower housing area and blower wheel with an antibacterial / antifungal cleaner. Use a biodegradable cleaning agent and degreaser on condenser fan and condenser shroud. Use warm or cold water when rinsing these items. Allow all items to dry thoroughly before reinstalling them.

3. Periodically (at least yearly or bi-yearly): inspect all control components, both electrical and mechanical, as well as the power supply. Use proper testing instruments (voltmeter, ohmmeter, ammeter, wattmeter, etc.) to perform electrical tests. Use an air conditioning or refrigeration thermometer to check room, outdoor and coil operating temperatures. Use a sling psychrometer to measure wet bulb temperatures indoors and outdoors.
4. Inspect the surrounding area (inside and outside) to ensure that the units' clearances have not been compromised or altered.
5. Inspect the sleeve and drain system periodically (at least yearly or bi-yearly) and clean of all obstructions and debris. Clean both areas with an antibacterial and antifungal cleaner. Rinse both items thoroughly with water and ensure that the drain outlets are operating correctly. Check the sealant around the sleeve and reseal areas as needed.
6. Clean the front cover when needed. Use a mild detergent. Wash and rinse with warm water. Allow it to dry thoroughly before reinstalling it in the chassis.

FRIEDRICH ROOM MODEL NUMBER CODE

W S 08 B 1 0 B

1st DIGIT - FUNCTION _____

W = Thru-The-Wall, WallMaster Series

2nd DIGIT - TYPE _____

S = Straight Cool
E = Electric Heat
Y = Heat Pump

3rd & 4th DIGITS - APPROXIMATE BTU/HR (Cooling) _____

Heating BTU/HR capacity listed in Specifications/Performance Data Section

5th DIGIT - ALPHABETICAL MODIFIER _____

6th DIGIT - VOLTAGE _____

1 = 115 Volts
3 = 230-208 Volts

7th DIGIT _____

0 = Straight Cool & Heat Pump Models
ELECTRIC HEAT MODELS
3 = 3 KW Heat Strip, Nominal

8th DIGIT _____

Major Change

RAC SERIAL NUMBER IDENTIFICATION GUIDE



<p>Serial Number</p> <p>Decade Manufactured</p> <p>L=0 C=3 F=6 J=9</p> <p>A=1 D=4 G=7</p> <p>B=2 E=5 H=8</p>	L	C	G	R	<p style="text-align: center;">00001</p> <p style="text-align: center;">Production Run Number</p>
<p>Year Manufactured</p> <p>A=1 D=4 G=7 K=0</p> <p>B=2 E=5 H=8</p> <p>C=3 F=6 J=9</p>					<p>Product Line</p> <p>R = RAC</p> <p>P = PTAC</p> <p>E = EAC</p> <p>V = VPAK</p> <p>H = Split</p>
<p>Month Manufactured</p> <p>A=Jan D=Apr G=Jul K=Oct</p> <p>B=Feb E=May H=Aug L=Nov</p> <p>C=Mar F=Jun J=Sept M=Dec</p>					

PERFORMANCE DATA

Model #	EVAPORATOR AIR TEMP. DEG. F		EVAPORATOR TEMP. DEG. F		CONDENSER TEMP. DEG. F		OPERATING PRESSURES				ELECTRICAL RATINGS				BREAKER FUSE			
	Discharge Air	Temp. Drop F.	E (in)	E (out)	Temp. DEG. F	Suction Temp	Liquid Temp	Super Heat	Sub-Cooling	Suction	Discharge	Amps Cool	Amps Heat	Locked Rotor Amps		Charge in OZ.	Evap CFM	Motor RPM
WS08B10A	55	25	55	55	127	61	102	18	25	87	281	7.1	36.2	20.5	257	1100	15	
WS10B10A	52	28	53	51	128	68	105	16	24	79	293	9.0	45.0	22.0	248	1100	15	
WS14B10A	52	28	52	52	128	63	99	14	28	82	297	12.4	58.0	44.9	293	1300	15	
WS10B30A	55	25	53	57	131	68	106	16	23	77	289	4.6	26.0	22.5	235	1100	15	
WS13B30B	51	29	52	50	128	57	100	13	30	78	295	6.5	27.4	35.2	281	1300	15	
WS16B30A	52	28	51	53	121	54	99	18	32	74	315	7.7	35.0	47.6	292	1421	15	
WE10B33A	53	27	54	52	126	82	99	16	31	82	289	4.6	15.2	45.0	38.0	225	1074	20
WE13B33B	52	29	52	51	127	80	103	13	29	80	295	6.5	15.7	27.4	35.0	274	1318	20
WE16B33A	52	28	51	53	121	57	100	18	30	74	315	6.5	16.1	35.0	35.2	281	1305	20
WY10B33A	53	27	54	52	126	80	99	16	31	82	225	4.6	4/15.2	26.0	38.0	225	1074	20
WY13B33A	52	29	52	51	127	80	103	16	29	80	300	6.5	5.6/15.7	27.4	35.0	260	1200	20

Model #	Cooling Capacity BTU/h	Heating Capacity BTU/h	Volts Rated	Cooling Amps	Cooling Watts	Heating Amps	Heating Watts	Energy Efficiency Ratio EER	Moisture Removal Pints/Hr.	Room Side Air Circulation	Net Weight Lbs.
WS08B10A	8000	—	115	6.8	762	—	—	10.5	1.3	245	93
WS10B10A	10000	—	115	8.7	954	—	—	10.5	2.4	245	103
WS14B10A	13500	—	115	12.0	1415	—	—	9.5	3.3	295	112
WS10B30A	10000/10000	—	230/208	4.6/5.0	1005/996	—	—	10.0/10.0	2.1	260	101
WS13B30B	12500/12000	—	230/208	6.3/6.7	1404/1379	—	—	8.9/8.7	3.3	280	109
WS16B30A	15800/15000	—	230/208	7.8/8.5	1756/1705	—	—	9.0/8.8	4.2	290	119
WE10B33A	10000/10000	11000/9100	230/208	4.6/5.0	1005/996	16.0/14.7	3550/2950	10.0/10.0	2.1	260	103
WE13B33B	12500/12000	11000/9100	230/208	6.3/6.7	1404/1379	16.0/14.7	3550/2950	8.9/8.7	3.3	280	111
WE16B33A	15800/15000	11000/9100	230/208	7.8/8.5	1756/1705	16.0/14.7	3550/2950	9.0/8.8	4.2	290	121
WY10B33A	10100/9800	8100/7800	230/208	4.6/4.8	1013/976	3.9/4.0	857/821	10.0/10.0	2.5	230	107
WY13B33A	12500/12100	10400/10000	230/208	6.4/6.8	1389/1352	5.4/5.7	1182/1136	9.0/9.0	3.2	280	116

Installation Information

Model Numbers	Circuit Rating Breaker or T-D Fuse	Plug Face (NEMA#)	Wall Outlet Appearance
WS08B10A, WS14B10A	125V - 15A	5 - 15P	
WS10B30A, WS13B30A, WS16B30A	250V - 15A	6 - 15P	
WE10, WE13, WE16, WY10, WY13	250V - 20A	6 - 20P	

Sleeve Dimensions

Model	Height	Width	Depth	Depth with Front	Minimum Extension Into Room	Minimum Extension Outside	Thru-the-wall Finished Hole Height
	WSC Sleeve Chassis	16 3/4"	27"	16 3/4"	23"	7 1/2"	9/16"
	15 3/4"	26 1/2"	21"	—	—	—	—

* Rating Conditions: 80 degrees F, room air temp. & 50% relative humidity, with 95 degree F, outside air temp & 40% relative humidity

Calculate the heat loss of the space to be heated. As long as the heat loss does not exceed the resistance heating capacity rating of the unit, the heating performance will be satisfactory. Change-over from heat pump operation to resistance operation on models indicated is automatic at a preset outside ambient temperature of approximately 35°F. If condensate disposal is desired, an optional drain kit is available. DEFROST CONTROL: Initiated at 20°F (outdoor coil temperature) and terminated at 43°F (outdoor coil temperature). During defrost, the compressor stops and the electric heat starts, then operates with the fan to maintain indoor comfort. Below 43°F, the unit remains in electric heat mode. During electric heat mode, the unit will achieve the following ratings: 11000/9100 BTU/h, 16.0/14.7 amps, and 3550/2950 watts. DEFROST DRAIN: Drain automatically opens at approximately 50°F in outdoor base pan for defrost condensate disposal.

ELECTRICAL DATA

Wire Size	Use ONLY wiring size recommended for single outlet branch circuit.
Fuse/Circuit Breaker	Use ONLY type and size fuse or HACR circuit breaker indicated on unit's rating plate. Proper current protection to the unit is the responsibility of the owner.
Grounding	Unit MUST be grounded from branch circuit through service cord to unit, or through separate ground wire provided on permanently connected units. Be sure that branch circuit or general purpose outlet is grounded.
Receptacle	The field supplied outlet must match plug on service cord and be within reach of service cord. Do NOT alter the service cord or plug. Do NOT use an extension cord. Refer to the table above for proper receptacle and fuse type.

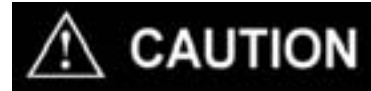

ELECTRIC SHOCK HAZARD.

Turn off electric power before service or installation.

All electrical connections and wiring MUST be installed by a qualified electrician and conform to the National Electrical Code and all local codes which have jurisdiction.

Failure to do so can result in property damage, personal injury and/or death.



The consumer - through the AHAM Room Air Conditioner Certification Program - can be certain that the AHAM Certification Seal accurately states the unit's cooling and heating capacity rating, the amperes and the energy efficiency ratio.



FUNCTIONAL COMPONENTS

A. Mechanical components

Bellows condensate valve

Temperature-sensitive valve that opens up to drain off condensate water when the outside temperature falls below 40°F and closes when the outside temperature reaches 58°F.

Plenum assembly

Diffuser with directional louvers used to direct the conditioned airflow.

Blower wheel

Attaches to the indoor side of the fan motor shaft and is used for distributing unconditioned, room side air through the heat exchanger and delivering conditioned air into the room.

Slinger fan blade

Attaches to the outdoor side of the fan motor shaft and is used to move outside air through the condenser coil, while slinging condensate water out of the base pan and onto the condenser coil, thus lowering the temperature and pressures within the coil.

B. Electrical components

Thermostat

Used to maintain the specified room side comfort level

System switch

Used to regulate the operation of the fan motor, the compressor or to turn the unit off. For troubleshooting, refer to the wiring diagrams and schematics in the back of this service manual.

Capacitor

Reduces line current and steadies the voltage supply, while greatly improving the torque characteristics of the fan motor and compressor motor.

MoneySaver[®] switch

When engaged, it sends the power supply to the fan motor through the thermostat, which allows for a cycle-fan operation.

Fan Motor

Dual-shafted fan motor operates the indoor blower wheel and the condenser fan blade simultaneously.

Solenoid

Used to energize the reversing valve on all heat pump units.

Heating element

Electric resistance heater, available in 3.3, 4.0 or 5.2 kW on select TwinTemp[®] models.

Heat anticipator

Used to provide better thermostat and room air temperature control.

C. Hermetic components

Compressor

Motorized device used to compress refrigerant through the sealed system.

Reversing valve

A four-way switching device used on all heat pump models to change the flow of refrigerant to permit heating or cooling.

Check valve

A pressure-operated device used to direct the flow of refrigerant to the proper capillary tube, during either the heating or cooling cycle.

Capillary tube

A cylindrical meter device used to evenly distribute the flow of refrigerant to the heat exchangers (coils.)

SYSTEM CONTROL PANEL

("WS" Models)

Figure 6: System Control Panel



TESTING THE ELECTRONIC CONTROL

CHECKING ROOM TEMPERATURE

1. Check the room temperature at the electronic control pad by pressing at the same time the "FAN SPEED" button and the temperature "UP" button on **XQ & WS models**.
2. The indoor temperature will display for 10 seconds. Indoor temperature can be viewed in all modes, including the TEST mode. The display can be changed back to SET temperature by pressing any key, except the ON/OFF button, or after 10seconds has elapsed.

ACTIVATING TEST MODE

Activate test mode by pressing at the same time the "MODE" button and the temperature "DOWN" button on **XQ & WS models**. LEDs for Hour, Start, and Stop will blink 1bps while Test Mode is active.

Test Mode has duration of 90 minutes. Test Mode can be activated under any conditions, including Off. Test Mode is cancelled by pressing the On/Off button, unplugging the unit, or when the 90 minutes is timed out. All settings revert to the factory default settings of Cool, 75 degrees F, Timer and Set Hour features are nonfunctional.

Test Mode overrides the three-minute lockout, all delays for compressor and fan motor start / speed change, and no delay when switching modes.

Test Mode default settings are ON, Money Saver, 60 degrees F, and High fan speed.

Activating Error Code Mode (Submode of Test Mode)

Unit must be in Test Mode to enter Error Code Mode

1. Activate Error Code Mode by pressing the "TIMER ON/OFF" button on **XQ & WS models**. LED for the "TIMER ON/OFF" will flash 1bps while Error Code Mode is active. Pressing the "TEMP/HR +" button will display 00. Consecutive presses will scroll through all error codes logged. Press the "TEMP/HR -" button to see the reverse order of all error codes logged. When the end of logged error codes is reached the temperature set point will appear.

IMPORTANT

Error Codes are cleared from the log by exiting from Error Code Mode. To exit on XQ & WS models, press Timer On/Off button. Or unplug unit to exit Error Code Mode. Plug unit in after 5 seconds to resume normal operation of unit.

ERROR CODE LISTINGS

- E1 SHORT CYCLE SITUATION:** Defined as compressor powered on before the three minute time delay ten times in one hour. Investigate and correct short cycling problem.
- E2 KEYBOARD STUCK ERROR:** If key button(s) are pressed continuously for twenty seconds or more. If **MODE** key is stuck, unit will default to cool. Exit Error Code Mode to see if error "E2" is no longer displayed and unit is functioning. Replace board if "E2" still displays after exiting Error Code Mode.
- E3 FROST PROBE OPEN:** Normal operation is allowed. Ohm frost probe. Replace probe if ohm value not read. If ohm value present replace board.
- E4 FROST PROBE SHORT:** Normal operation allowed. Replace probe.
- E5 INDOOR PROBE OPEN:** Control assumes indoor ambient temperature is 90 degree F and unit will operate. Ohm indoor probe. Replace probe if ohm value not read.
- E6 INDOOR PROBE SHORT:** Control assumes ambient temperature is 90 degree F and unit will operate. Replace probe.

NOTE: All Error Code displays for Frost & Indoor Probe will allow unit to operate. Unit may or will ice up if faulty components not replaced.

Frost Probe Sensor: Disables compressor at 35 degrees F +/- 3 degrees F

Indoor Probe Sensor: Control range is 60 degrees F to 90 degrees F +/- 2 degrees F

Indoor temperature will be displayed by pressing:

(XQ / WS Units) The **Fan Speed** button and the **Temp Up button**.

The indoor temperature will be displayed for 10 seconds. The display will change back to the Set Point temperature by pressing any key button except for the On/Off button. The indoor temperature can be viewed in all modes, including test mode.

Keep Alive: The electronic control has a memory to retain all functions and status as set up by the user in the event of a power failure. Once power is restored to the unit there is a two second delay before the fan comes on and approximately three minutes delay before the compressor is activated, providing that the mode was set for cooling and the set point temperature has not been met in the room.

SYSTEM CONTROL SWITCH

("WE" & "WY" Models)

An eight position switch is used to regulate the operation of the fan motor, compressor and electric heater.

The unit can be operated in cooling or heating mode with the compressor or electric heater on and the fan motor operating on low, medium or high speed.

The fan motor can also be operated independently on medium speed. See switch section as indicated on decorative control panel, in Figure 7.

Figure 7: System Control Panel

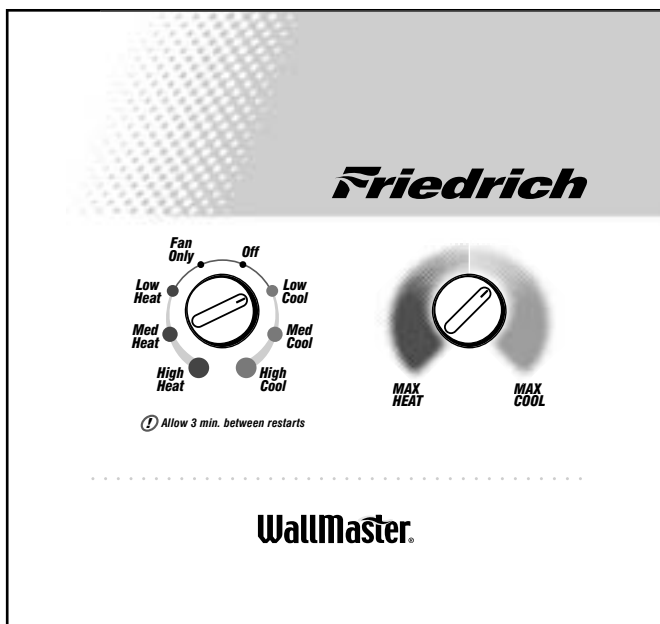

SYSTEM CONTROL SWITCH - TEST

Disconnect leads from control switch. Turn control to position being tested (see Figure 8). There must be continuity as follows:

1. "Off" Position-no continuity between terminals.
2. "Lo Cool" Position-between terminals "C" and "3", "C2" and "2", "LO" and "M/S", "AR" and "5".
3. "Med Cool" Position-between terminals "C" and "3", "C2" and "2", "M" and "M/S", "AR" and "5".
4. "Hi Cool" Position-between terminals "C" and "3", "C2" and "2", "H" and "M/S", "AR" and "5".
5. "Hi Heat" Position-between terminals "C" and "1", "C2" and "4", "H" and "M/S", "AR" and "5".
6. "Med Heat" Position-between terminals "C" and "1", "C2" and "4", "M" and "M/S", "AR" and "5".
7. "Lo Cool" Position-between terminals "C" and "1", "C2" and "4", "LO" and "M/S", "AR" and "5".
8. "Fan Only" Position-between terminals "L1", "M" and "2".

Figure 8: System Control Switch (Heat Pump & Electric Heat Models)

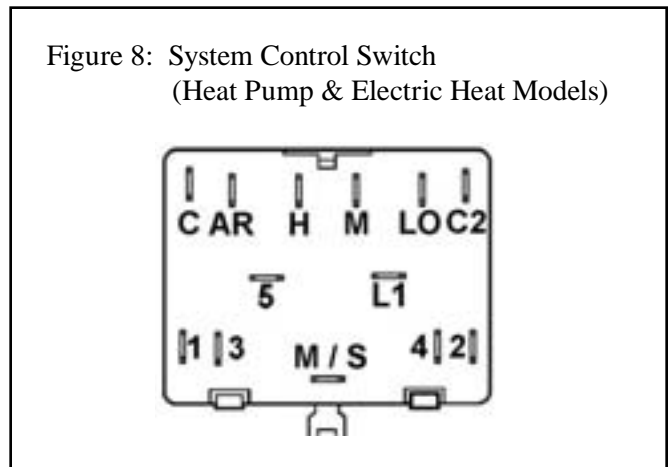

NOTE:

Units will operate in constant fan in the cooling mode and auto fan in the heating mode.

REFRIGERATION SYSTEM SEQUENCE OF OPERATION

A good understanding of the basic operation of the refrigeration system is essential for the service technician. Without this understanding, accurate troubleshooting of refrigeration system problems will be more difficult and time consuming, if not (in some cases) entirely impossible. The refrigeration system uses four basic principles (laws) in its operation they are as follows:

1. "Heat always flows from a warmer body to a cooler body."
2. "Heat must be added to or removed from a substance before a change in state can occur"
3. "Flow is always from a higher pressure area to a lower pressure area."
4. "The temperature at which a liquid or gas changes state is dependent upon the pressure."

The refrigeration cycle begins at the compressor. Starting the compressor creates a low pressure in the suction line which draws refrigerant gas (vapor) into the compressor. The compressor then "compresses" this refrigerant, raising its pressure and its (heat intensity) Temperature.

The refrigerant leaves the compressor through the discharge line as a hot high pressure gas (vapor). The refrigerant enters the condenser coil where it gives up some of its heat. The condenser fan moving air across the coil's finned surface facilitates the transfer of heat from the refrigerant to the relatively cooler outdoor air.

When a sufficient quantity of heat has been removed from the refrigerant gas (vapor), the refrigerant will "condense" (i.e. change to a liquid). Once the refrigerant has been condensed (changed) to a liquid it is cooled even further by the air that continues to flow across the condenser coil.

The RAC design determines at exactly what point (in the condenser) the change of state (i.e. gas to a liquid) takes place. In all cases, however, the refrigerant must be totally condensed (changed) to a liquid before leaving the condenser coil.

The refrigerant leaves the condenser coil through the liquid line as a warm high pressure liquid. It next will pass through the refrigerant drier (if so equipped). It is the function of the drier to trap any moisture present in the system, contaminants, and large particulate matter.

The liquid refrigerant next enters the metering device. The metering device is a capillary tube. The purpose of the metering device is to "meter" (i.e. control or measure) the quantity of refrigerant entering the evaporator coil.

In the case of the capillary tube this is accomplished (by design) through size (and length) of device, and the pressure difference present across the device.

Since the evaporator coil is under a lower pressure (due to the suction created by the compressor) than the liquid line, the liquid refrigerant leaves the metering device entering

the evaporator coil. As it enters the evaporator coil, the larger area and lower pressure allows the refrigerant to expand and lower its temperature (heat intensity). This expansion is often referred to as "boiling". Since the unit's blower is moving Indoor air across the finned surface of the evaporator coil, the expanding refrigerant absorbs some of that heat. This results in a lowering of the indoor air temperature, hence the "cooling" effect.

The expansion and absorbing of heat cause the liquid refrigerant to evaporate (i.e. change to a gas). Once the refrigerant has been evaporated (changed to a gas), it is heated even further by the air that continues to flow across the evaporator coil.

The particular system design determines at exactly what point (in the evaporator) the change of state (i.e. liquid to a gas) takes place. In all cases, however, the refrigerant must be totally evaporated (changed) to a gas before leaving the evaporator coil.

The low pressure (suction) created by the compressor causes the refrigerant to leave the evaporator through the suction line as a cool low pressure vapor. The refrigerant then returns to the compressor, where the cycle is repeated.

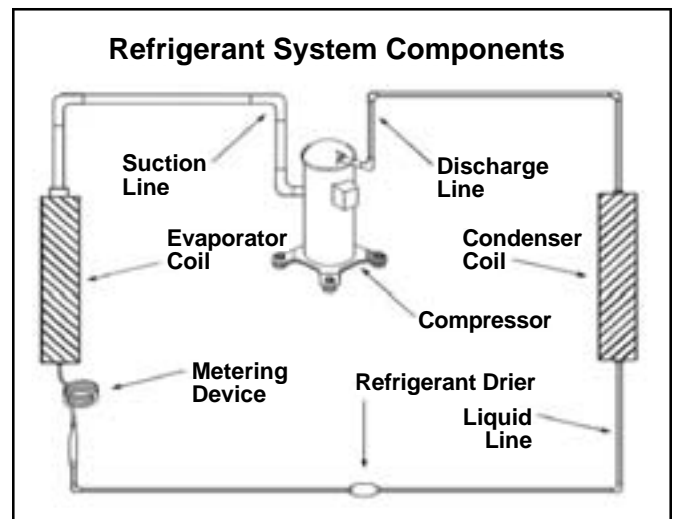

SEALED REFRIGERATION SYSTEM REPAIRS

IMPORTANT

ANY SEALED SYSTEM REPAIRS TO COOL-ONLY MODELS REQUIRE THE INSTALLATION OF A LIQUID LINE DRIER. ALSO, ANY SEALED SYSTEM REPAIRS TO HEAT PUMP MODELS REQUIRE THE INSTALLATION OF A SUCTION LINE DRIER.

SEALED REFRIGERATION SYSTEM REPAIRS

EQUIPMENT REQUIRED:

1. Voltmeter
2. Ammeter
3. Ohmmeter
4. Vacuum Pump (capable of 200 microns or less vacuum.)
5. Acetylene Welder
6. Electronic Halogen Leak Detector (G.E. Type H-6 or equivalent.)
7. Accurate refrigerant charge measuring device such as:
 - a. Balance Scales - 1/2 oz. accuracy
 - b. Charging Board - 1/2 oz. accuracy
8. High Pressure Gauge - (0 - 400 lbs.)
9. Low Pressure Gauge - (30 - 150 lbs.)
10. Vacuum Gauge - (0 - 1000 microns)

EQUIPMENT MUST BE CAPABLE OF:

1. Evacuation from both the high side and low side of the system simultaneously.
2. Introducing refrigerant charge into high side of the system.
3. Accurately weighing the refrigerant charge actually introduced into the system.
4. Facilities for flowing nitrogen through refrigeration tubing during all brazing processes.

HERMETIC COMPONENT REPLACEMENT

The following procedure applies when replacing components in the sealed refrigeration circuit or repairing refrigerant leaks. (Compressor, condenser, evaporator, capillary tube, refrigerant leaks, etc.)

1. Recover the refrigerant from the system at the process tube located on the high side of the system by installing a line tap on the process tube. Apply gauge from process tube to EPA approved gauges from process tube to EPA approved recovery system. Recover CFCs in system to at least 5%.
2. Cut the process tube below pinch off on the suction side of the compressor.
3. Connect the line from the nitrogen tank to the suction process tube.
4. Drift dry nitrogen through the system and unsolder the more distant connection first. (Filter drier, high side process tube, etc.)
5. Replace inoperative component, and always install a new filter drier. Drift dry nitrogen through the system when making these connections.
6. Pressurize system to 30 PSIG with proper refrigerant and boost refrigerant pressure to 150 PSIG with dry nitrogen.
7. Leak test complete system with electric halogen leak detector, correcting any leaks found.
8. Reduce the system to zero gauge pressure.
9. Connect vacuum pump to high side and low side of system with deep vacuum hoses, or copper tubing. (Do not use regular hoses.)

10. Evacuate system to maximum absolute holding pressure of 200 microns or less. NOTE: This process can be speeded up by use of heat lamps, or by breaking the vacuum with refrigerant or dry nitrogen at 5,000 microns. Pressure system to 5 PSIG and leave in system a minimum of 10 minutes. Release refrigerant, and proceed with evacuation of a pressure of 200 microns or less.
11. Break vacuum by charging system from the high side with the correct amount of refrigerant specified. This will prevent boiling the oil out of the crankcase.
NOTE: If the entire charge will not enter the high side, allow the remainder to enter the low side in small increments while operating the unit.
12. Restart unit several times after allowing pressures to stabilize. Pinch off process tubes, cut and solder the ends. Remove pinch off tool, and leak check the process tube ends.

SPECIAL PROCEDURE IN THE CASE OF MOTOR COMPRESSOR BURNOUT

1. Recover all refrigerant and oil from the system.
2. Remove compressor, capillary tube and filter drier from the system.
3. Flush evaporator condenser and all connecting tubing with dry nitrogen or equivalent, to remove all contamination from system. Inspect suction and discharge line for carbon deposits. Remove and clean if necessary.
4. Reassemble the system, including new drier strainer and capillary tube.
5. Proceed with processing as outlined under hermetic component replacement.

ROTARY COMPRESSOR SPECIAL TROUBLESHOOTING AND SERVICE

Basically, troubleshooting and servicing rotary compressors is the same as on the reciprocating compressor with only a few exceptions.

1. Because of the spinning motion of the rotary, the mounts are critical. If vibration is present, check the mounts carefully.
2. The electrical terminals on the rotary are in a different order than the reciprocating compressors. The terminal markings are on the cover gasket. Use your wiring diagram to insure correct connections.

REFRIGERANT CHARGE

1. The refrigerant charge is extremely critical. Measure charge carefully - as exact as possible to the nameplate charge.
2. The correct method for charging the rotary is to introduce liquid refrigerant into the high side of the system with the unit off. Then start compressor and enter the balance of the charge, gas only, into the low side.

The introduction of liquid into the low side, without the use of a capillary tube, will cause damage to the discharge valve of the rotary compressor.

NOTE: All inoperative compressors returned to Friedrich must have all lines properly plugged with the plugs from the replacement compressor.

TROUBLESHOOTING TOUCH TEST CHART: TO SERVICE REVERSING VALVES

NORMAL FUNCTION OF VALVE										
VALVE OPERATING CONDITION	DISCHARGE TUBE from Compressor	SUCTION TUBE to Compressor	Tube to INSIDE COIL	Tube to OUTSIDE COIL	LEFT Pilot Capillary Tube	RIGHT Pilot Capillary Tube	NOTES: * TEMPERATURE OF VALVE BODY ** WARMER THAN VALVE BODY			
	1	2	3	4	5	6	POSSIBLE CAUSES	CORRECTIONS		
Normal Cooling	Hot	Cool	Cool as (2)	Hot as (1)	*TVB	TVB				
Normal Heating	Hot	Cool	Hot as (1)	Cool as (2)	*TVB	TVB				
MALFUNCTION OF VALVE										
Valve will not shift from cool to heat.	Check Electrical circuit and coil						No voltage to coil.	Repair electrical circuit.		
	Check refrigeration charge						Defective coil.	Replace coil.		
	Hot						Low charge.	Repair leak, recharge system.		
	Cool						Pressure differential too high.	Recheck system.		
	Cool, as (2)						Hot, as (1)	*TVB	Hot	Pilot valve okay. Dirt in one bleeder hole.
Hot, as (1)						*TVB	Hot	Piston cup leak	Stop unit. After pressures equalize, restart with solenoid energized. If valve shifts, reattempt with compressor running. If still no shift, replace valve.	
Valve will not shift from cool to heat.	Hot	Cool	Cool, as (2)	Hot, as (1)	*TVB	*TVB	Clogged pilot tubes.	Raise head pressure, operate solenoid to free. If still no shift, replace valve.		
	Hot	Cool	Cool, as (2)	Hot, as (1)	Hot	Hot	Both ports of pilot open. (Back seat port did not close).	Raise head pressure, operate solenoid to free partially clogged port. If still no shift, replace valve.		
	Warm	Cool	Cool, as (2)	Hot, as (1)	*TVB	Warm	Defective Compressor.	Replace compressor		
Starts to shift but does not complete reversal.	Hot	Warm	Warm	Hot	*TVB	Hot	Not enough pressure differential at start of stroke or not enough flow to maintain pressure differential.	Check unit for correct operating pressures and charge. Raise head pressure. If no shift, use valve with smaller port.		
	Hot						Hot	Hot	Body damage.	Replace valve
	Hot	Warm	Warm	Hot	Hot	Hot	Both ports of pilot open.	Raise head pressure, operate solenoid. If no shift, use valve with smaller ports.		
	Hot	Hot	Hot	Hot	*TVB	Hot	Body damage.	Replace valve		
	Hot						Hot	Hot	Valve hung up at mid-stroke. Pumping volume of compressor not sufficient to maintain reversal.	Raise head pressure, operate solenoid. If no shift, use valve with smaller ports.
Hot						Hot	Hot	Both ports of pilot open.	Raise head pressure, operate solenoid. If no shift, replace valve.	
Apparent leap in heating.	Hot	Cool	Hot, as (1)	Cool, as (2)	*TVB	*TVB	Piston needle on end of slide leaking.	Operate valve several times, then recheck. If excessive leak, replace valve.		
	Hot	Cool	Hot, as (1)	Cool, as (2)	** WVB	** WVB	Pilot needle and piston needle leaking.	Operate valve several times, then recheck. If excessive leak, replace valve.		
Will not shift from heat to cool.	Hot	Cool	Hot, as (1)	Cool, as (2)	*TVB	*TVB	Pressure differential too high.	Stop unit. Will reverse during equalization period. Recheck system		
	Hot						Hot	Hot	Clogged pilot tube.	Raise head pressure, operate solenoid to free dirt. If still no shift, replace valve.
	Hot	Cool	Hot, as (1)	Cool, as (2)	Hot	*TVB	Dirt in bleeder hole.	Raise head pressure, operate solenoid. Remove valve and wash out. Check on air before reinstalling, if no movement, replace valve. Add strainer to discharge tube. Mount valve horizontally.		
	Hot	Cool	Hot, as (1)	Cool, as (2)	Hot	*TVB	Piston cup leak.	Stop unit. After pressures equalize, restart with solenoid deenergized. If valve shifts, reattempt with compressor running. If it still will not reverse while running, replace the valve.		
	Hot	Cool	Hot, as (1)	Cool, as (2)	Hot	Hot	Defective pilot.	Replace valve.		
	Warm	Cool	Warm, as (1)	Cool, as (2)	Warm	*TVB	Defective compressor.	Replace compressor		

COOLING ONLY ROOM AIR CONDITIONERS: TROUBLESHOOTING TIPS

Problem	Possible Cause	Action
Compressor does not run	Low voltage	Check voltage at compressor. 115V & 230V units will operate at 10% voltage variance
	T-stat not set cold enough or inoperative	Set t-stat to coldest position. Test t-stat & replace if inoperative
	Compressor hums but cuts off on B10 overload	Hard start compressor. Direct test compressor. If compressor starts, add starting components
	Open or shorted compressor windings	Check for continuity & resistance
	Open overload	Test overload protector & replace if inoperative
	Open capacitor	Test capacitor & replace if inoperative
	Inoperative system switch	Test for continuity in all positions. Replace if inoperative
	Broken, loose or incorrect wiring	Refer to appropriate wiring diagrams to check wiring

Problem	Possible Cause	Action
Fan motor does not run	Inoperative system switch	Test switch & replace if inoperative
	Broken, loose or incorrect wiring	Refer to applicable wiring diagram
	Open capacitor	Test capacitor & replace if inoperative
	Fan speed switch open	Test switch & replace if inoperative
	Inoperative fan motor	Test fan motor & replace if inoperative (be sure internal overload has had time to reset)

Problem	Possible Cause	Action
Does not cool or only cools slightly	Undersized unit	Refer to industry standard sizing chart
	T-stat open or inoperative	Set to coldest position. Test t-stat & replace if necessary
	Dirty filter	Clean as recommended in Owner's Manual
	Dirty or restricted condenser or evaporator coil	Use pressure wash or biodegradable cleaning agent to clean
	Poor air circulation	Adjust discharge louvers. Use high fan speed
	Fresh air or exhaust air door open on applicable models	Close doors. Instruct customer on use of this feature
	Low capacity - undercharge	Check for leak & make repair
	Compressor not pumping properly	Check amperage draw against nameplate. If not conclusive, make pressure test

Problem	Possible Cause	Action
Unit does not run	Fuse blown or circuit tripped	Replace fuse, reset breaker. If repeats, check fuse or breaker size. Check for shorts in unit wiring & components
	Power cord not plugged in	Plug it in
	System switch in "OFF" position	Set switch correctly
	Inoperative system switch	Test for continuity in each switch position
	Loose or disconnected wiring at switch or other components	Check wiring & connections. Reconnect per wiring diagram

Problem	Possible Cause	Action
Evaporator coil freezes up	Dirty filter	Clean as recommended in Owner's Manual
	Restricted airflow	Check for dirty or obstructed coil. Use pressure wash or biodegradable cleaning agent to clean
	Inoperative t-stat	Test for shorted t-stat or stuck contacts
	Short of refrigerant	De-ice coil & check for leak
	Inoperative fan motor	Test fan motor & replace if inoperative
	Partially restricted capillary tube	De-ice coil. Check temp. differential (delta T) across coil. Touch test coil return bends for same temp. Test for low running current

Problem	Possible Cause	Action
Compressor runs continually & does not cycle off	Excessive heat load	Unit undersized. Test cooling performance & replace with larger unit if needed
	Restriction in line	Check for partially iced coil & check temperature split across coil
	Refrigerant leak	Check for oil at silver soldered connections. Check for partially iced coil. Check split across coil. Check for low running amperage
	T-stat contacts stuck	Check operation of t-stat. Replace if contacts remain closed.
	T-stat incorrectly wired	Refer to appropriate wiring diagram

Problem	Possible Cause	Action
T-stat does not turn unit off	T-stat contacts stuck	Disconnect power to unit. Remove cover of t-stat & check if contacts are stuck. If so, replace t-stat
	T-stat set at coldest point	Turn to higher temp. setting to see if unit cycles off
	Incorrect wiring	Refer to appropriate wiring diagrams
	Unit undersized for area to be cooled	Refer to industry standard sizing chart

Problem	Possible Cause	Action
Compressor runs for short periods only. Cycles on overload	Overload inoperative. Opens too soon	Check operation of unit. Replace overload if system operation is satisfactory
	Compressor restarted before system pressures equalized	Allow a minimum of 2 minutes to allow pressures to equalize before attempting to restart. Instruct customer of waiting period
	Low or fluctuating voltage	Check voltage with unit operating. Check for other appliances on circuit. Air conditioner should be in separate circuit for proper voltage & fused separately
	Incorrect wiring	Refer to appropriate wiring diagram
	Shorted or incorrect capacitor	Check by substituting a known good capacitor of correct rating
	Restricted or low air flow through condenser coil	Check for proper fan speed or blocked condenser
	Compressor running abnormally hot	Check for kinked discharge line or restricted condenser. Check amperage

Problem	Possible Cause	Action
T-stat does not turn unit on	Loss of charge in t-stat bulb	Place jumper across t-stat terminals to check if unit operates. If unit operates, replace t-stat.
	Loose or broken parts in t-stat	Check as above
	Incorrect wiring	Refer to appropriate wiring diagram

Problem	Possible Cause	Action
Noisy operation	Poorly installed	Refer to Installation Manual for proper installation
	Fan blade striking chassis	Reposition - adjust motor mount
	Compressor vibrating	Check that compressor grommets have not deteriorated. Check that compressor mounting parts are not missing
	Improperly mounted or loose cabinet parts	Check assembly & parts for looseness, rubbing & rattling

Problem	Possible Cause	Action
Water leaks into the room	Evaporator drain pan overflowing	Clean obstructed drain trough
	Condensation forming on base pan	Evaporator drain pan broken or cracked. Reseal or replace
	Poor installation resulting in rain entering the room	Check installation instructions. Reseal as required
	Condensation on discharge grille louvers	Clean the dirty evaporator coil. Use pressure wash or biodegradable cleaning agent to clean
	Chassis gasket not installed	Install gasket, per Installation manual
	Downward slope of unit is too steep	Refer to installation manual for proper installation

Problem	Possible Cause	Action
Water "spitting" into room	Sublimation: When unconditioned saturated, outside air mixes with conditioned air, condensation forms on the cooler surfaces	Ensure that foam gaskets are installed in between window panes & in between the unit & the sleeve. Also, ensure that fresh air/exhaust vents (on applicable models) are in the closed position & are in tact
	Downward pitch of installation is too steep	Follow installation instructions to ensure that downward pitch of installed unit is no less than 1/4" & no more than 3/8"
	Restricted coil or dirty filter	Clean & advise customer of periodic cleaning & maintenance needs of entire unit

Problem	Possible Cause	Action
Excessive moisture	Insufficient air circulation thru area to be air conditioned	Adjust louvers for best possible air circulation
	Oversized unit	Operate in "MoneySaver" position
	Inadequate vapor barrier in building structure, particularly floors	Advise customer

Problem	Possible Cause	Action
T-stat short cycles	T-stat differential too narrow	Replace t-stat
	Plenum gasket not sealing, allowing discharge air to short cycle t-stat	Check gasket. Reposition or replace as needed
	Restricted coil or dirty filter	Clean & advise customer of periodic cleaning & maintenance needs of entire unit

Problem	Possible Cause	Action
Prolonged off cycles (automatic operation)	Anticipator (resistor) wire disconnected at t-stat or system switch	Refer to appropriate wiring diagram
	Anticipator (resistor) shorted or open	Disconnect plus from outlet. Remove resistor from bracket. Insert plug & depress "COOL" & "FAN AUTOMATIC" buttons. Place t-stat to warmest setting. Feel resistor for temperature. If no heat, replace resistor
	Partial loss of charge in t-stat bulb causing a wide differential	Replace t-stat

Problem	Possible Cause	Action
Outside water leaks	Evaporator drain pan cracked or obstructed	Repair, clean or replace as required
	Water in compressor area	Detach shroud from pan & coil. Clean & remove old sealer. Reseal, reinstall & check
	Obstructed condenser coil	Use pressure wash or biodegradable cleaning agent to clean
	Fan blade/slinger ring improperly positioned	Adjust fan blade to 1/2" of condenser coil

HEAT / COOL ROOM AIR CONDITIONERS: TROUBLESHOOTING TIPS

Problem	Possible Cause	Action
Room temperature uneven (Heating cycle)	Heat anticipator (resistor) shorted (on applicable models)	Disconnect power to unit. Remove resistor from t-stat bulb block. Plus in unit & allow to operate. Feel resistor for heat. If not heat, replace resistor
	Wide differential - partial loss of t-stat bulb charge	Replace t-stat & check
	Incorrect wiring	Refer to appropriate wiring diagram. Resistor is energized during "ON" cycle of compressor or fan.

Problem	Possible Cause	Action
Unit will not defrost	Incorrect wiring	Refer to appropriate wiring diagram
	Defrost control timer motor not advancing (applicable models)	Check for voltage at "TM" & "TM1" on timer. If no voltage, replace control
	Defrost control out of calibration (applicable models)	If outside coil temperature is 25°F or below, & preselected time limit has elapsed, replace defrost control
	Defrost control contacts stuck	If contacts remain closed between terminals "2" & "3" of the defrost control after preselected time interval has passed, replace control
	Defrost control bulb removed from or not making good coil contact	Reinstall & be assured that good bulb to coil contact is made

Problem	Possible Cause	Action
Does not heat adequately	Exhaust or fresh air door open	Check if operating properly. Instruct customer on proper use of control
	Dirty filter	Clean as recommended in Owner's Manual
	Unit undersized	Check heat rise across coil. If unit operates efficiently, check if insulation can be added to attic or walls. If insulation is adequate, recommend additional unit or larger one
	Outdoor t-stat open (applicable models)	T-stat should close at 38°F. Check continuity of control. If temperature is below 38F, replace control
	Heater hi-limit control cycling on & off	Check for adequate fan air across heater. Check control for open at 160°F & close at 150°F
	Shorted supplementary heater	Ohmmeter check, approx. 32-35 ohms
	Incorrect wiring	Check applicable wiring diagram

Problem	Possible Cause	Action
Unit cools when heat is called for	Incorrect wiring	Refer to applicable wiring diagram
	Defective solenoid coil	Check for continuity of coil
	Reversing valve fails to shift	Block condenser coil & switch unit to cooling. Allow pressure to build up in system, then switch to heating. If valve fails to shift, replace valve.
	Inoperative system switch	Check for continuity of system switch

Problem	Possible Cause	Action
Cooling adequate, but heating insufficient	Heating capillary tube partially restricted	Check for partially starved outer coil. Replace heating capillary tube
	Check valve leaking internally	Switch unit several times from heating to cooling. Check temperature rise across coil. Refer to specification sheet for correct temperature rise
	Reversing valve failing to shift completely; bypassing hot gas	Deenergize solenoid coil, raise head pressure, energize solenoid to break loose. If valve fails to make complete shift, replace valve.

**WIRING DIAGRAM: MODELS WS08B10A-C, WS10B10A-C,
WS14B10A-C, WS10B30A-C, WS13B30C**

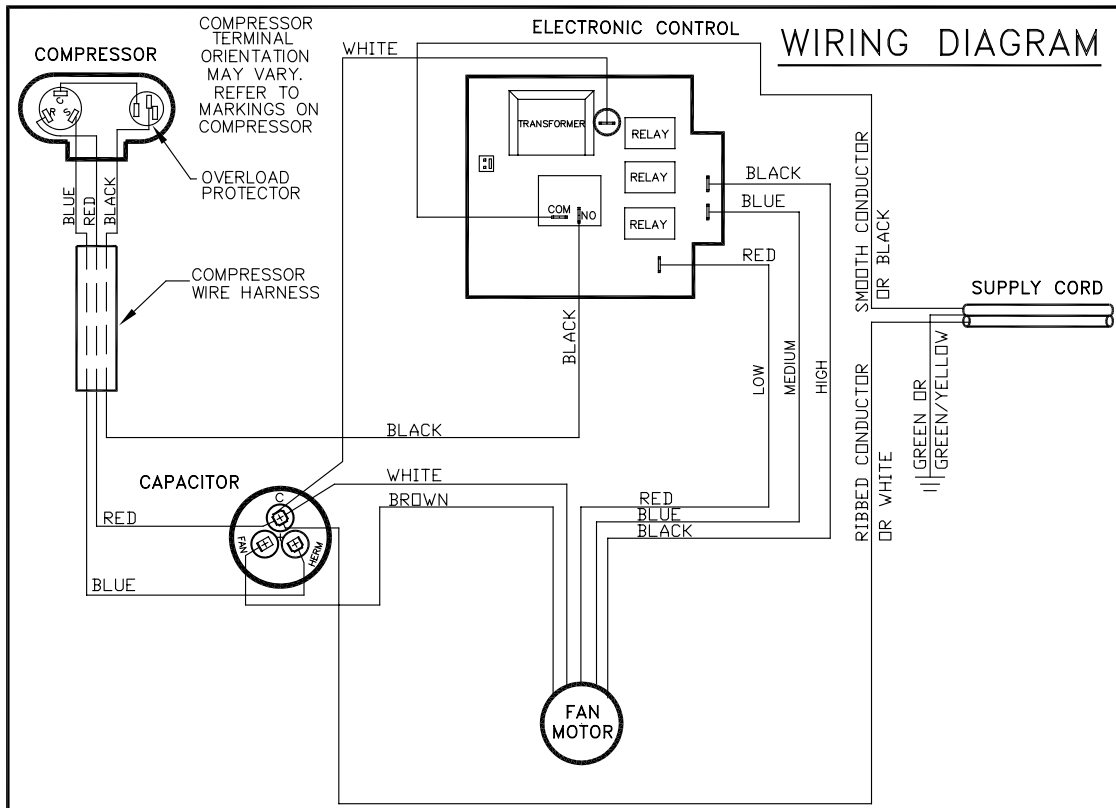

SCHEMATIC

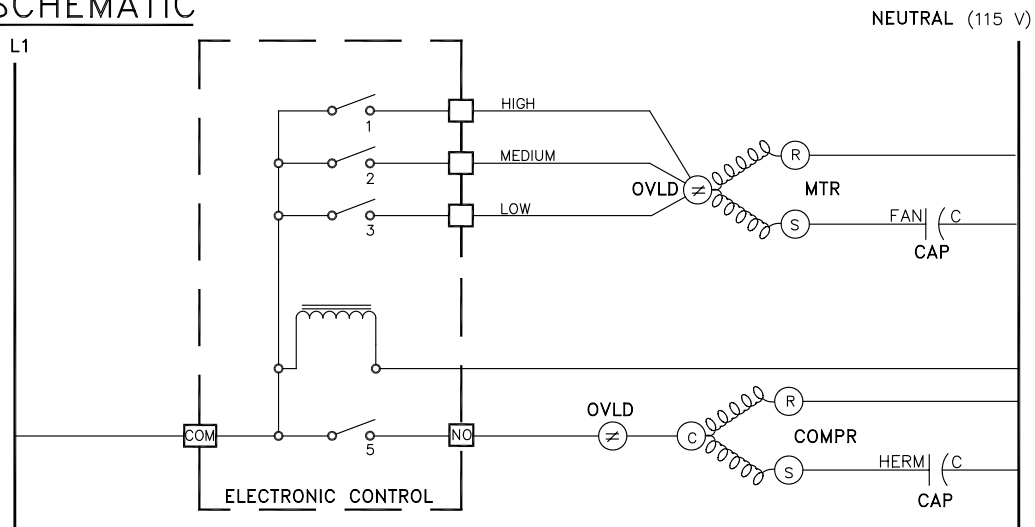

SWITCH LOGIC X = CLOSED
O = OPEN

SWITCH POSITION	CIRCUIT				
	1	2	3	4	5
OFF	0	0	0	0	0
HI COOL	X	0	0	0	X
MED COOL	0	X	0	0	X
LOW COOL	0	0	X	0	X

LEGEND

- CAP - CAPACITOR
- COMPR - COMPRESSOR
- MTR - FAN MOTOR
- OVLD - OVERLOAD PROTECTOR
- - INSULATED TERMINAL
- - COMBINATION TERMINAL
- ||— - GROUND LEAD

PART NO. 617-581-21 REV. 02

WIRING DIAGRAM: MODELS WS16B30A-C

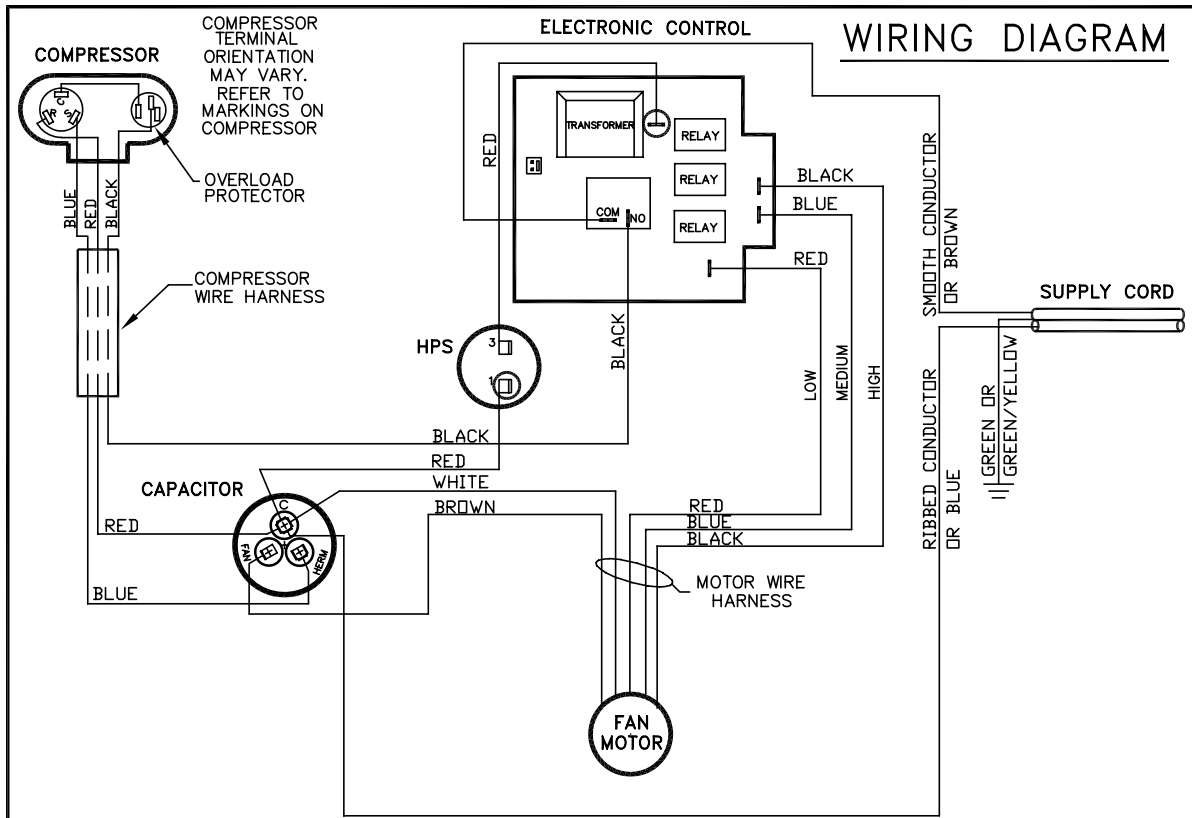

SCHEMATIC

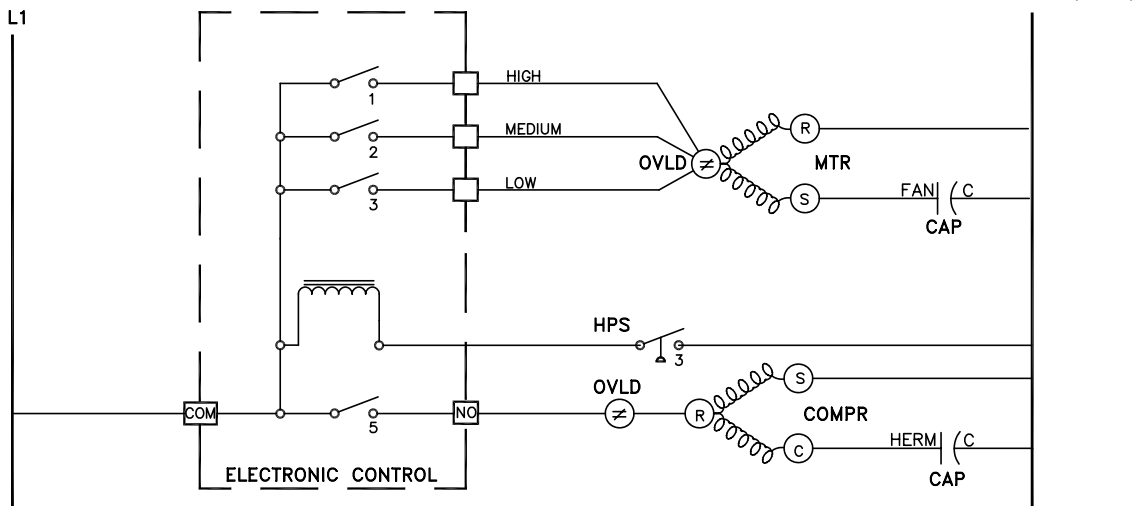

SWITCH LOGIC X = CLOSED
O = OPEN

SWITCH POSITION	1	2	3	4	5
OFF	0	0	0	0	0
HI COOL	X	0	0	0	X
MED COOL	0	X	0	0	X
LOW COOL	0	0	X	0	X

LEGEND

- CAP - CAPACITOR
- COMPR - COMPRESSOR
- MTR - FAN MOTOR
- OVLD - OVERLOAD PROTECTOR
- HPS - HIGH PRESSURE SWITCH
- INSULATED TERMINAL
- COMBINATION TERMINAL
- GROUND LEAD

PART NO. 617-581-20
 REV. 03

WIRING DIAGRAM: MODELS WE10B33A-B, WE13B33B-B

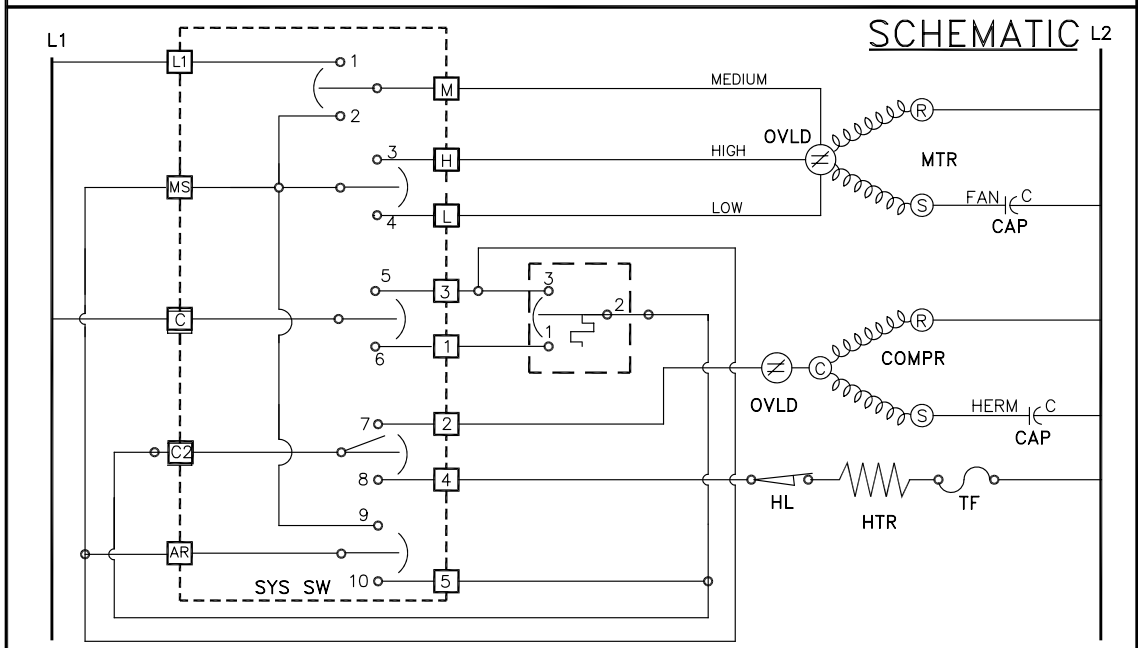
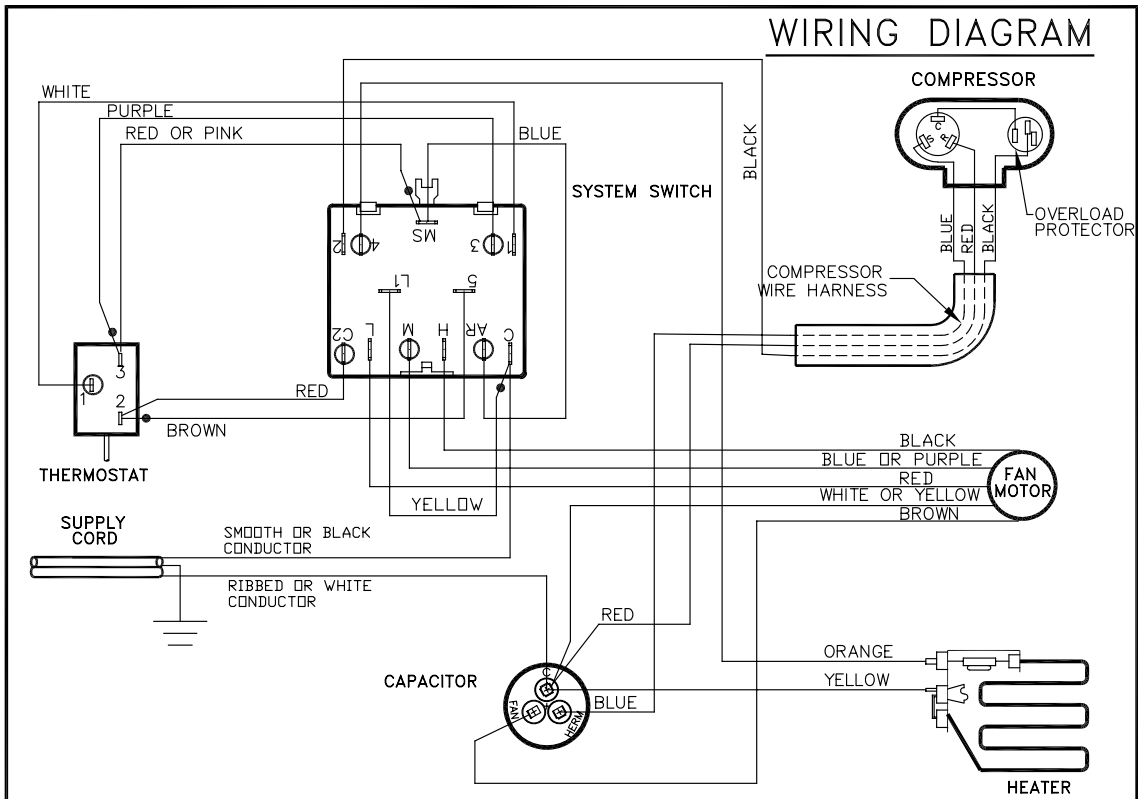

SWITCH POSITION	CIRCUIT									
	1	2	3	4	5	6	7	8	9	10
OFF	0	0	0	0	0	0	0	0	0	0
LOW COOL	0	0	0	X	X	0	X	X	0	0
MEDIUM COOL	0	X	0	X	X	X	X	0	X	0
HIGH COOL	0	0	X	0	X	X	X	X	0	0
HIGH HEAT	0	0	X	0	0	X	X	X	X	0
MEDIUM HEAT	0	X	0	0	0	X	X	X	X	0
LOW HEAT	0	0	0	X	0	X	X	X	X	0
FAN ONLY	X	0	0	0	0	0	0	0	0	0

- LEGEND**
- AR - ANTICIPATOR RESISTOR
 - MS - MONEY SAVER/ROCKER SWITCH
 - CAP - CAPACITOR
 - COMPR - COMPRESSOR
 - MTR - FAN MOTOR
 - OVLD - OVERLOAD PROTECTOR
 - SYS SW - SYSTEM SWITCH
 - IDT - INDOOR THERMOSTAT

- HTR - HEATER
- HL - HEATER LIMIT
- TF - THERMAL FUSE
- |— - GROUND LEAD
- - COMBINATION TERMINAL
- - PLASTIC INSULATOR

PART NO. 617-581-22 REV. 02

WIRING DIAGRAM: MODELS WE16B33A-B

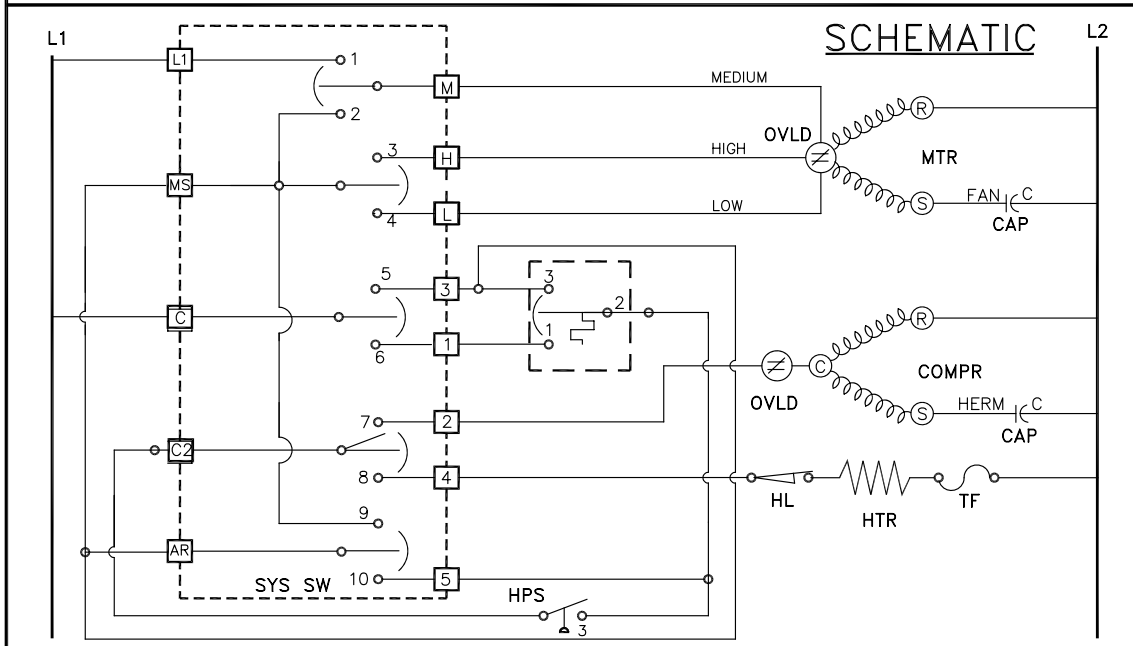
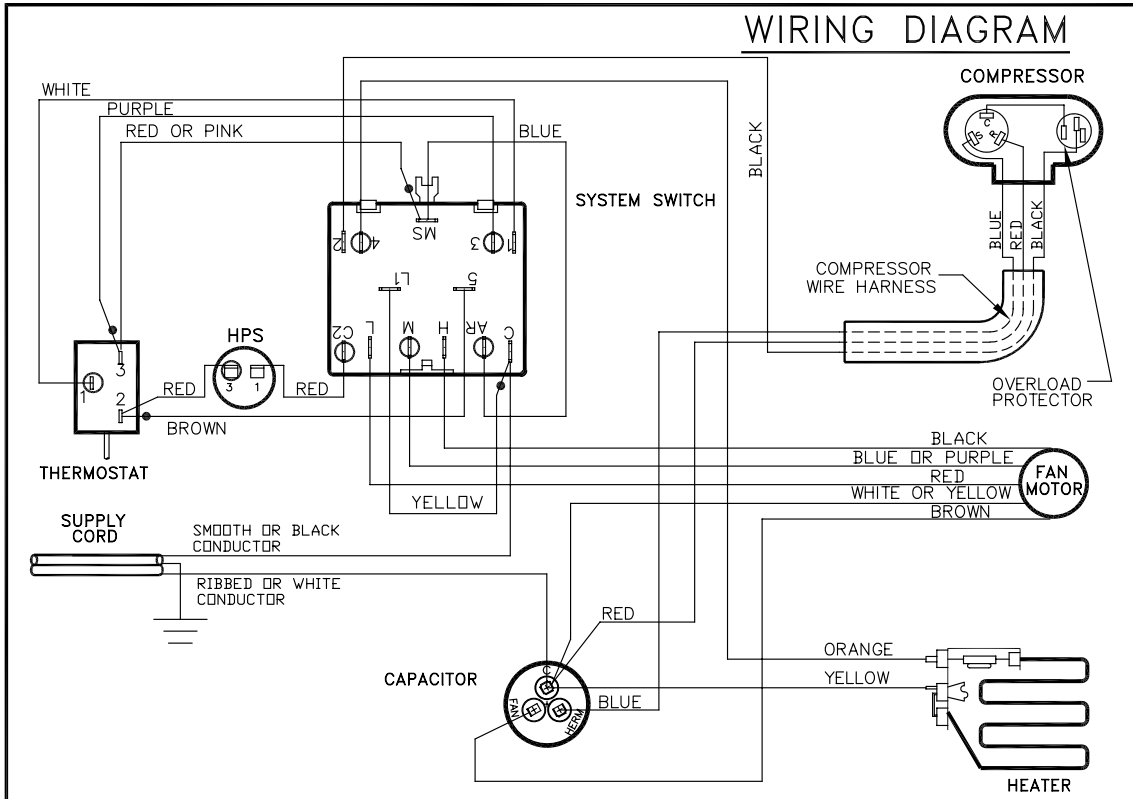

SWITCH LOGIC		X = CLOSED 0 = OPEN	
SWITCH POSITION	CIRCUIT		
OFF	1 2 3 4 5 6 7 8 9 10	0	0
LOW COOL		0	0
MEDIUM COOL		0	X
HIGH COOL		0	X
HIGH HEAT		0	X
MEDIUM HEAT		0	X
LOW HEAT		0	X
FAN ONLY		X	0

LEGEND	
AR	— ANTICIPATOR RESISTOR
MS	— MONEY SAVER/ROCKER SWITCH
CAP	— CAPACITOR
COMPR	— COMPRESSOR
MTR	— FAN MOTOR
OVLD	— OVERLOAD PROTECTOR
SYS SW	— SYSTEM SWITCH
IDT	— INDOOR THERMOSTAT
HPS	— HIGH PRESSURE SWITCH
HTR	— HEATER
HL	— HEATER LIMIT
TF	— THERMAL FUSE
	— GROUND LEAD
	— COMBINATION TERMINAL
	— PLASTIC INSULATOR

PART NO. REV.
617-581-15 04

WIRING DIAGRAM: MODELS WY10B33A-B, WY13B33A-B

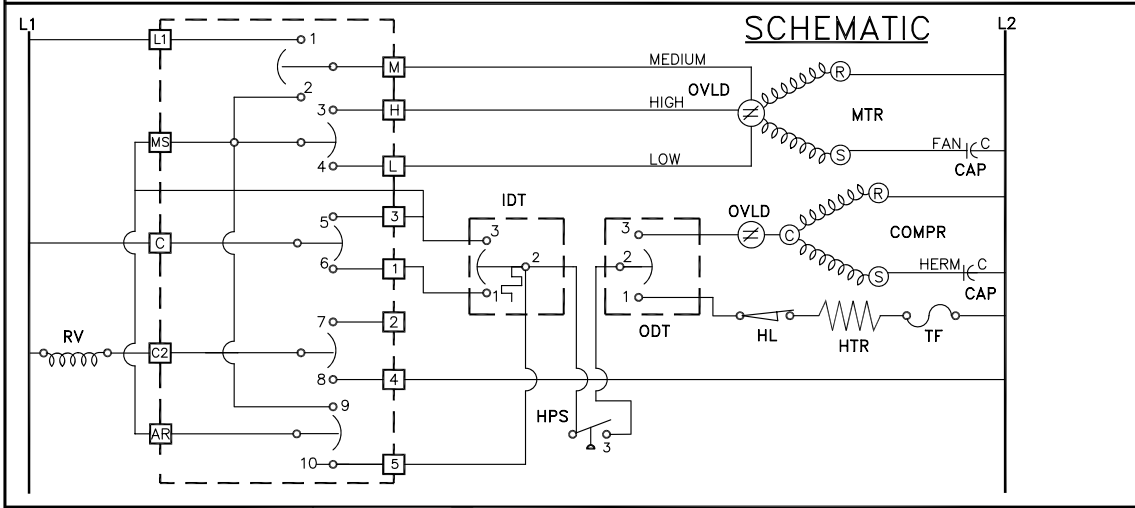
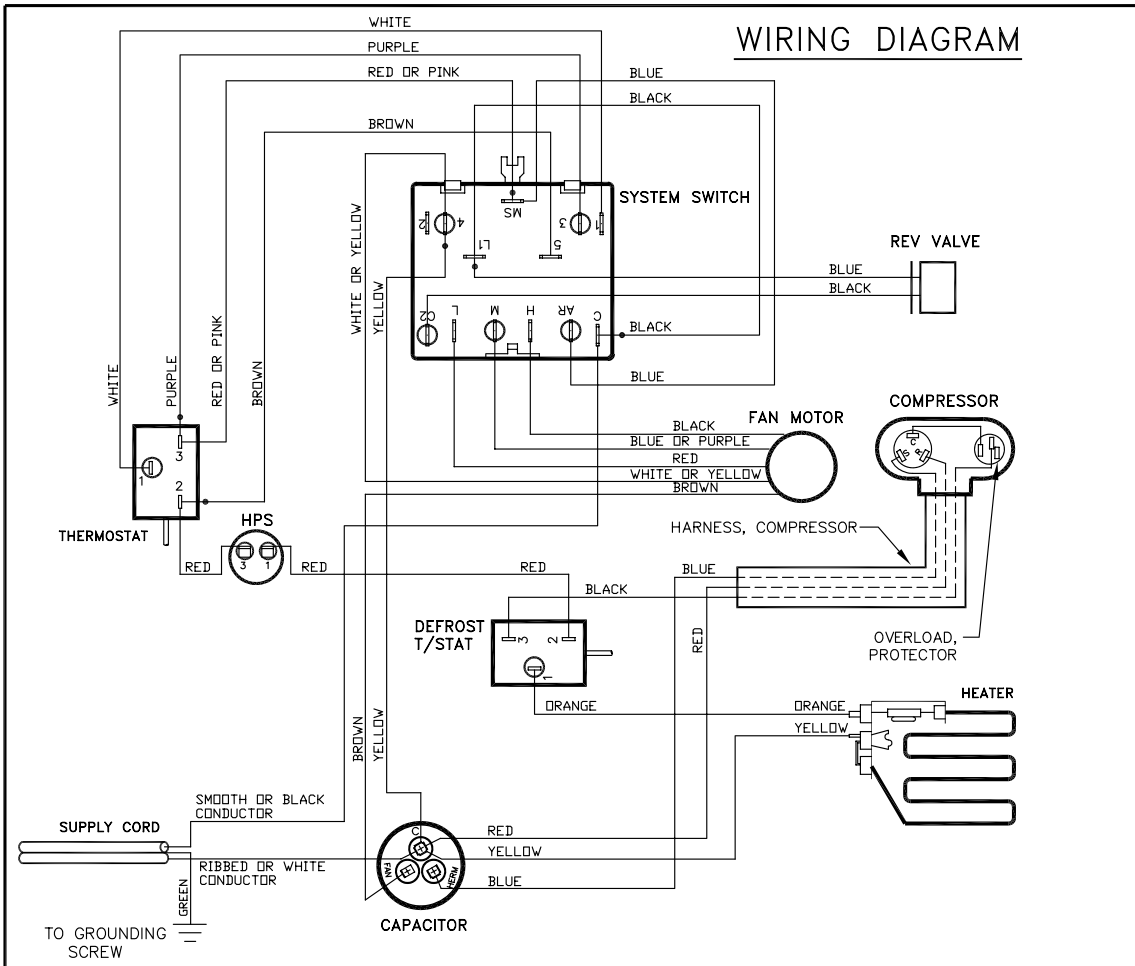

SWITCH LOGIC

X = CLOSED
O = OPEN

SWITCH POSITION	1	2	3	4	5	6	7	8	9	10
OFF	O	O	O	O	O	O	O	O	O	O
LOW COOL	O	O	X	X	O	X	O	X	O	O
MEDIUM COOL	O	X	O	O	X	O	X	O	X	O
HIGH COOL	O	O	X	O	X	O	X	O	X	O
HIGH HEAT	O	X	O	O	X	O	X	O	X	O
MEDIUM HEAT	O	X	O	O	X	O	X	O	X	O
LOW HEAT	O	O	X	O	X	O	X	O	X	O
FAN ONLY	X	O	O	O	O	O	O	O	O	O

LEGEND

MS	- MONEY SAVER	HTR	- HEATER
CAP	- CAPACITOR	HL	- HEATER LIMIT
COMPR	- COMPRESSOR	TF	- THERMAL FUSE
MTR	- FAN MOTOR	— —	- GROUND LEAD
OVLD	- OVERLOAD PROTECTOR	○	- COMBINATION TERMINAL
RV	- REVERSING VALVE	○	- PLASTIC INSULATOR
IDT	- INDOOR THERMOSTAT		
ODT	- OUTDOOR THERMOSTAT		
HPS	- HIGH PRESSURE SWITCH		

PART NO. 617-581-02 REV. 08

WS, WE & WY SERIES CHASSIS PARTS

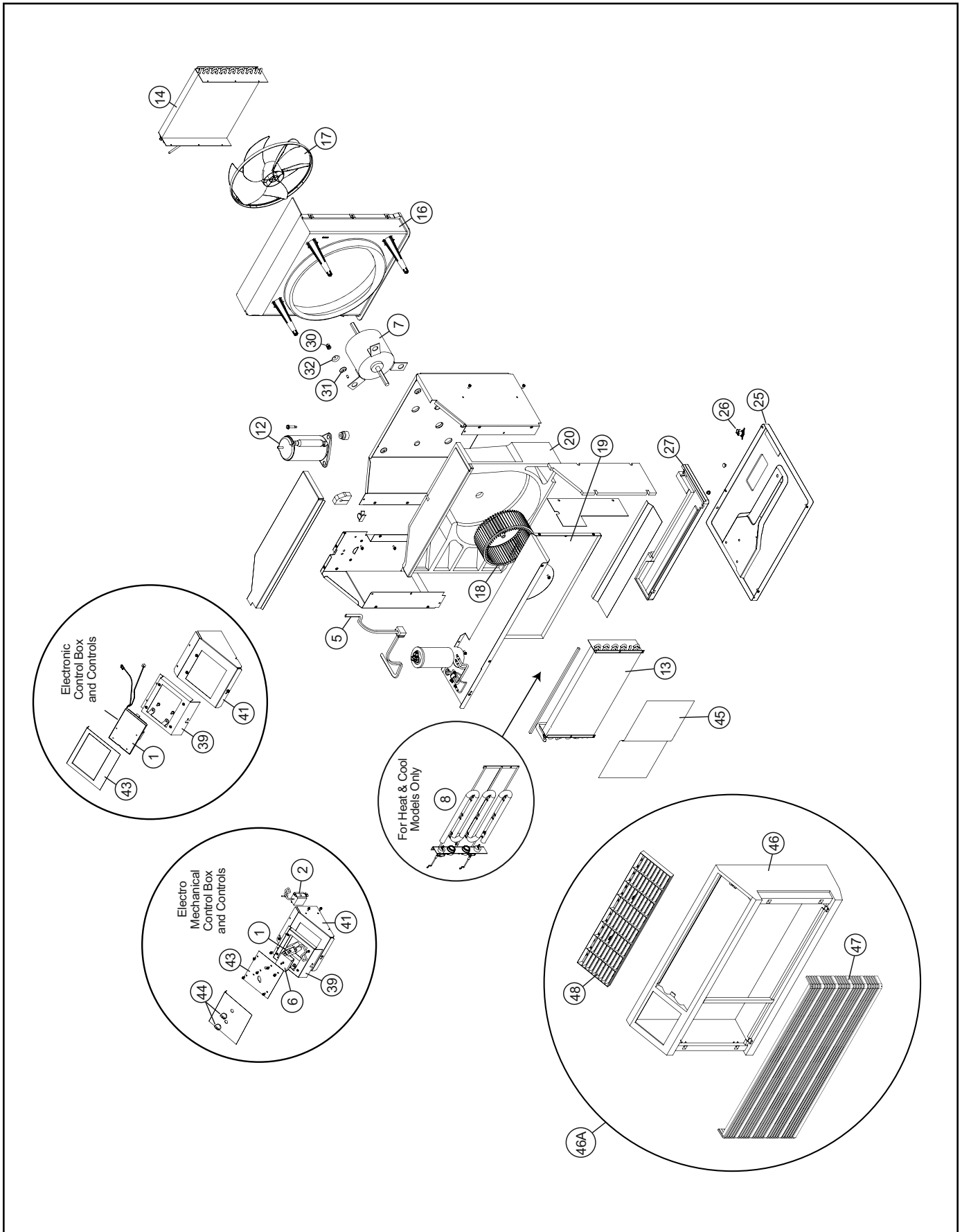

WALLMASTER PARTS 2007

REF	DESCRIPTION	PART NO.	115V			230V						CODE		
			WS08B10A-C	WS10B10A-C	WS14B10A-C	WS10B30A-C	WS13B30B-C	WS16B30A-C	WE10B33A-B	WE13B33B-B	WE16B33A-B		WY10B33A-B	WY13B33A-B
ELECTRICAL PARTS														
1	ELECTRONIC BOARD	61921198	1	1	1								331	
1	ELECTRONIC BOARD	61921199				1	1	1					331	
*	REMOTE CONTROL	61826606	1	1	1	1	1	1					350	
1	THERMOSTAT	25043302							1	1	1	1	120	
2	THERMOSTAT, DEF.	61350314										1	122	
3	OVERLOAD	61764507	1										190	
3	OVERLOAD	61764519		1									190	
3	OVERLOAD	61764528			1								190	
3	OVERLOAD	61764554					1			1			190	
3	OVERLOAD	61764555				1					1		190	
3	OVERLOAD	61764556						1					190	
4	CAPACITOR	61080533		1									150	
4	CAPACITOR	61080569			1								150	
4	CAPACITOR	61080535	1										150	
4	CAPACITOR	61080540				1			1			1	150	
4	CAPACITOR	61080526						1			1		150	
4	CAPACITOR	61080537					1			1			150	
5	SUPPLY CORD	60500327	1	1	1								220	
5	SUPPLY CORD	60500326							1	1	1	1	220	
5	SUPPLY CORD	60500325				1	1	1					220	
6	SWITCH SYS. 8 POS.	60607204							1	1	1	1	130	
7	FAN MOTOR	61871470			1								110	
7	FAN MOTOR	61871471				1			1			1	110	
7	FAN MOTOR	61871472	1	1									110	
7	FAN MOTOR	61871473					1			1			110	
7	FAN MOTOR	61871474						1			1		110	
8	HEATER	62101210							1	1	1	1	210	
9	SOLENOID and REVERSING VALVE	25022022										1	240	
REFRIGERATION SYSTEM PARTS														
			WS08B10A-C	WS10B10A-C	WS14B10A-C	WS10B30A-C	WS13B30B-C	WS16B30A-C	WE10B33A-B	WE13B33B-B	WE16B33A-B	WY10B33A-B	WY13B33A-B	
10	REVERSING VALVE and SOLENOID	25022022										1	1	500
11	CHECK VALVE	61824400										1	1	510
*	FILTER DRIER	60308101	1	1	1	1	1	1	1	1				480
*	SUCTION DRIER	61828200										1	1	480
12	COMPRESSOR	61562832	1											600
12	COMPRESSOR	62199700		1										600
12	COMPRESSOR	62199701			1									600
12	COMPRESSOR	62199702				1			1			1		600
12	COMPRESSOR	62199703					1			1			1	600
12	COMPRESSOR	62199704						1			1			600
13	EVAPORATOR COIL	62102300	1	1		1			1					400
13	EVAPORATOR COIL	62103300					1			1				400
13	EVAPORATOR COIL	62103303			1			1			1			400
13	EVAPORATOR COIL	62103305										1	1	400
14	CONDENSER COIL	62103400			1			1			1			410
14	CONDENSER COIL	62103401					1			1				410
14	CONDENSER COIL	62103402										1	1	410
14	CONDENSER COIL	62103500		1		1			1					410
14	CONDENSER COIL	62103501	1											410
*	CAPILLARY TUBE	03760513						1			1			471
*	CAPILLARY TUBE	03760547		1		1			1					471
*	CAPILLARY TUBE	01390000					1			1				471
*	CAPILLARY TUBE	03760550			1									471
*	CAPILLARY TUBE	03760511											1	471
*	CAPILLARY TUBE	03760548	1									1		471

* Part Not Shown

WALLMASTER PARTS 2007

REF	DESCRIPTION	PART NO.	115V			230V						CODE		
			WS08B10A-C	WS10B10A-C	WS14B10A-C	WS10B30A-C	WS13B30B-C	WS16B30A-C	WE10B33A-B	WE13B33B-B	WE16B33A-B		WY10B33A-B	WY13B33A-B
16	SHROUD, CONDENSER	62102000	1	1	1	1	1	1	1	1	1	1	1	720
17	FAN BLADE, COND.	62101500	1	1	1	1	1	1	1	1	1	1	1	710
18	BLOWER WHEEL, EVAP.	60610604	1	1	1	1	1	1	1	1	1	1	1	700
19	BLOWER FRONT	62100600			1									742
19	BLOWER FRONT	62100601	1	1		1	1	1	1	1	1	1	1	742
20	SCROLL	62102100	1	1	1	1	1	1	1	1	1	1	1	777
25	BASE PAN	62100914	1											730
25	BASE PAN	62100915		1	1	1	1	1						730
25	BASE PAN ASLY.	61606219							1	1	1	1	1	730
26	BELLOWS,DRAIN VALVE	60179903							1	1	1	1	1	801
27	DRAIN PAN, ASSY.	62101901	1	1	1	1	1	1	1	1	1	1	1	840
*	GROMMET, comp.	61028900	3	3	3	3	3	3	3	3	3	3	3	790
*	BOLT, comp.	91400400	3	3	3	3	3	3	3	3	3	3	3	791
*	COUNTER WEIGHT	61715800	2	2	2	2	2	2	2	2	2	2	2	999
30	RETAINER CUP,FAN MTR	60640600	3	3	3	3	3	3	3	3	3	3	3	999
31	GROMMET,FAN MTR	60640500	3	3	3	3	3	3	3	3	3	3	3	999
32	NUT,FAN MTR	91003000	3	3	3	3	3	3	3	3	3	3	3	999
39	PANEL, CTRL. MOUNT	62100002	1	1	1	1	1	1	1	1	1	1	1	999
41	BRACKET CONRTOL	62100802	1	1	1	1	1	1	1	1	1	1	1	999
43	ESCUTCHEON, HTG/COOL	62101107							1	1	1	1	1	760
44	KNOBS, CRTL.	61911605							2	2	2	2	2	761
*	HOLDER, AIR FILTER	60865900	2	2	2	2	2	2	2	2	2	2	2	756
*	HOLDER, THERMOSTAT	61900500							1	1	1	1	1	999
*	HOLDER, THERMISTER	61925001	1	1	1	1	1	1						999
45	FILTER, AIR	60865811	1	1	1	1	1	1	1	1	1	1	1	754
*	FRONT COMPLETE	61607005	1	1	1	1	1	1	1	1	1	1	1	750
46	FRAME HOOD	62103205	1	1	1	1	1	1	1	1	1	1	1	750
47	GRILLE, INTAKE	61612705	1	1	1	1	1	1	1	1	1	1	1	772
48	GRILLE, EXHAUST	61612805	1	1	1	1	1	1	1	1	1	1	1	773
53	END CAP, GRILLE	61613205	1	1	1	1	1	1	1	1	1	1	1	999
*	WEATHER SEAL GASKET	61578101	1	1	1	1	1	1	1	1	1	1	1	999
*	HARDWARE, SCREWS	60846020	1	1	1	1	1	1	1	1	1	1	1	999
*	GASKET, CHASSIS	61717301	1	1	1	1	1	1	1	1	1	1	1	780
*	CARTON	61841919	1	1	1	1	1	1	1	1	1	1	1	999
OPTIONAL ACCESSORIES														
*	START KIT	61008903	1	1	1	1	1	1	1	1	1	1	1	160
55	SLEEVE (ONLY)	61603611	1	1	1	1	1	1	1	1	1	1	1	770
57	GRILLE, STAMPED	61603011	1	1	1	1	1	1	1	1	1	1	1	771

* Part Not Shown

WS - WE - WY SERIES SLEEVE PARTS

REF	DESCRIPTION	PART NO.											
1	SLEEVE ASSEMBLY	61603611	1	1	1	1	1	1	1	1	1	1	1
2	PANEL, WEATHER INNER	61603201	1	1	1	1	1	1	1	1	1	1	1
3	GRILLE, LOUVERED	61603011	1	1	1	1	1	1	1	1	1	1	1
4	PANEL, WEATHER OUTER	61603303	1	1	1	1	1	1	1	1	1	1	1

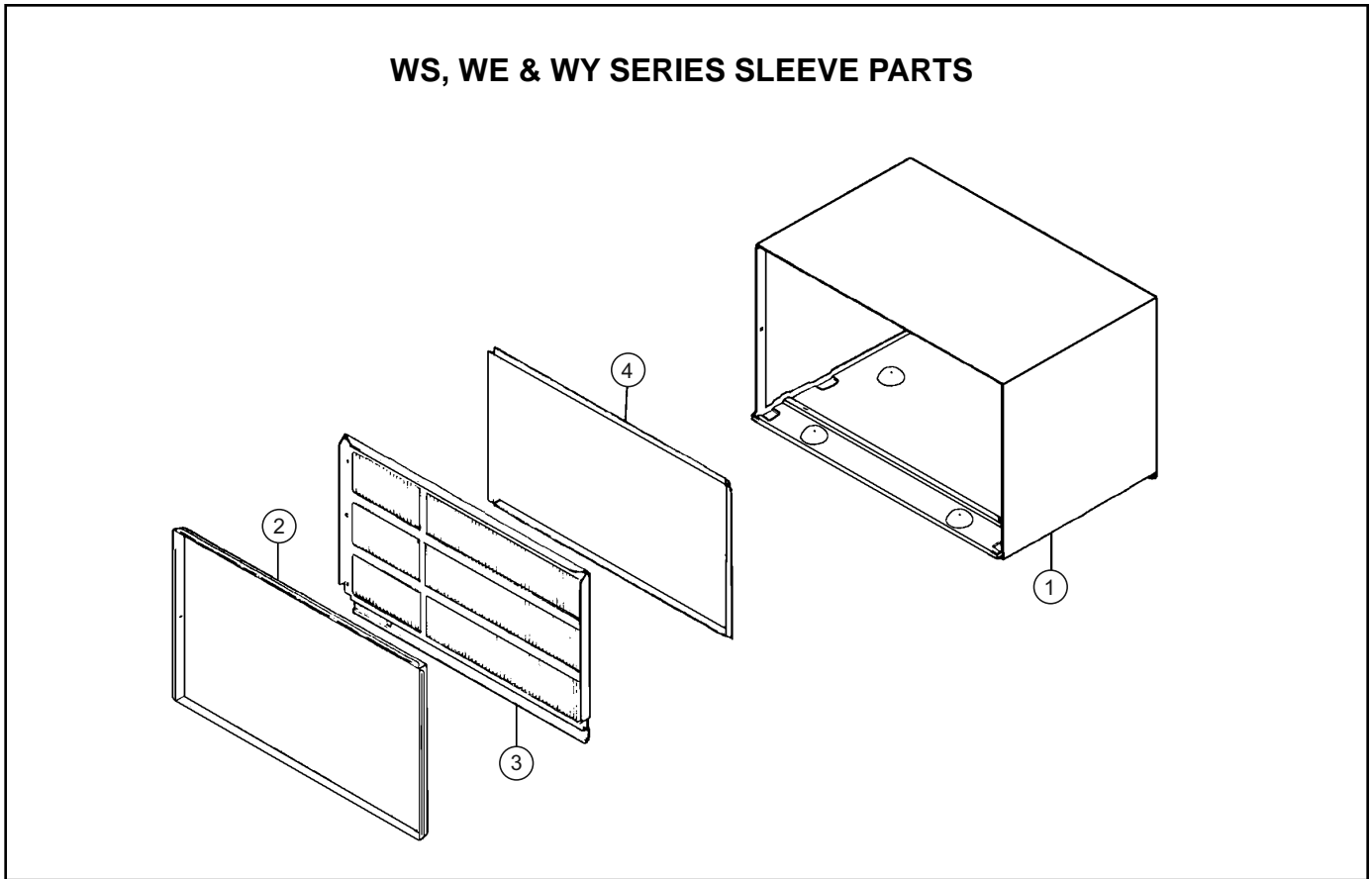



Friedrich Air Conditioning Co.

Post Office Box 1540 • San Antonio, Texas 78295-1540

4200 N. Pan Am Expressway • San Antonio, Texas 78218-5212

(210) 357-4400 • FAX (210) 357-4480

www.friedrich.com

Printed in the U.S.A.

WM-Svc-Prts-07 (12-07)