

Frigidaire

Factory Parts Catalog

Product No.	AEQ8000FE0
Series	Frigidaire
Market	North America
Color	black
Volts	240
Wiring Diagram	134682200
Owner's Guide	134760100
Installation Instructions	134759900
Operating Instructions	134609300

 **Electrolux**

Electrolux Major Appliances
North & Latin America
P.O. BOX 212378
AUGUSTA, GA 30917

Publication No.
5995494035
07/06/29
(EN/SERVICE/WTC)
361

ELECTRIC DRYER

Model No.
AEQ8000f

Copyright © 2007 Electrolux Home Products, Inc.
All rights reserved.

CABINET/DRUM

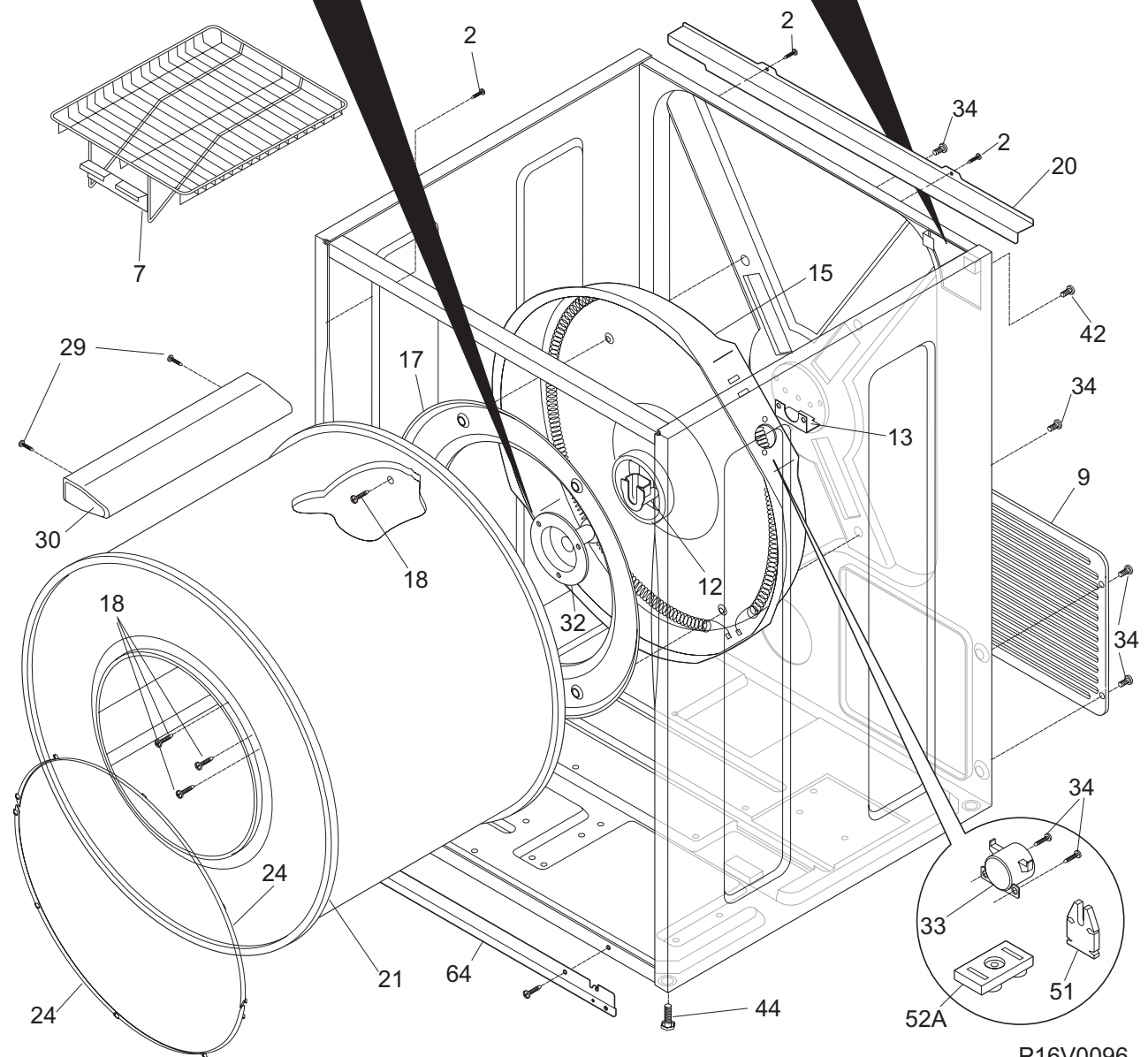
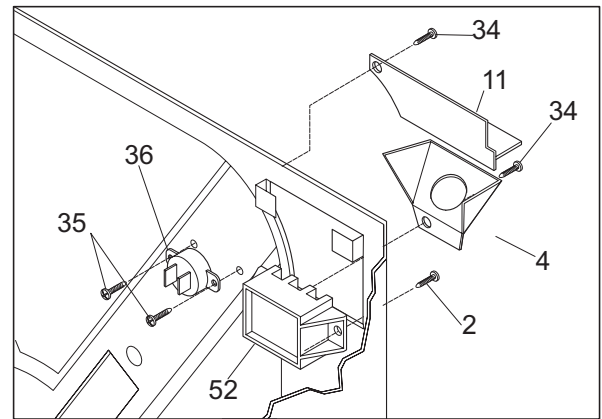
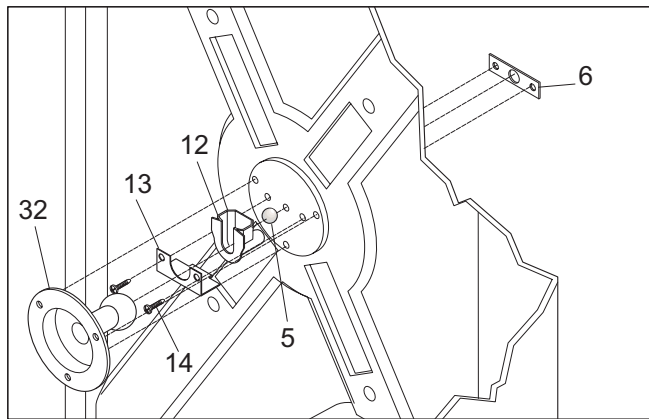

P16V0096

CABINET/DRUM

POS. NO	PART NO.	DESCRIPTION
2	131168200	Screw, pan head, 8-18B x 0.31
4	131785200	Bracket, elec power cord, knock out
5	5303281019	Ball, grounding
6	5303281020	Clip, ball, steel, flat nut
7	134121200	Rack, drying
9	131793200	Panel, service access, rear
11	5303211428	Cover, terminal block
12	131825900	Bearing, drum support
13	131724300	Bracket, bearing support
14	131205400	Screw, bracket mtg., 10-16B x 1.375, cr/sq drive
15 #	131553900	Heater Assy, w/housing/felt
17	3204254	Baffle, heater shield
18	131477000	Screw, 10-16AB x 0.375
20	134166500	Bracket, top panel mtg., rear
21	134122552	Drum, dryer, stainless steel, service kit
24	131963900	Glide, drum
29	131382300	Screw, quadrex head, 10-14 x 1.00, vane mtg., special
30	5304405283	Vane, straight, gray
32	131777700	Shaft, drum support, ballhitch
32*	5303307893	Lubricant, high temp
33 #	3204267	Thermostat, safety
34	131243700	Screw, pan head, 8-18AB x 0.375
35	131892100	Screw, 6-20B x 0.230
36 #	134120900	Thermal Limiter
42	134154100	Screw, hex washer head, 10-32 x 0.375, ground
44	134344900	Leveling Leg, screw
51	131472100	Insulator, heater housing
52 #	134101400	Terminal Block, main
52A#	3202786	Terminal Block, heater housing
64	134360100	Bracket, svce panel mtg.
* #	134394200	Wiring Harness, main
* #	5303281153	Rear Bearing Kit, includes 5, 6, 12, 13, 14, 18, 32

FRONT PANEL/LINT FILTER

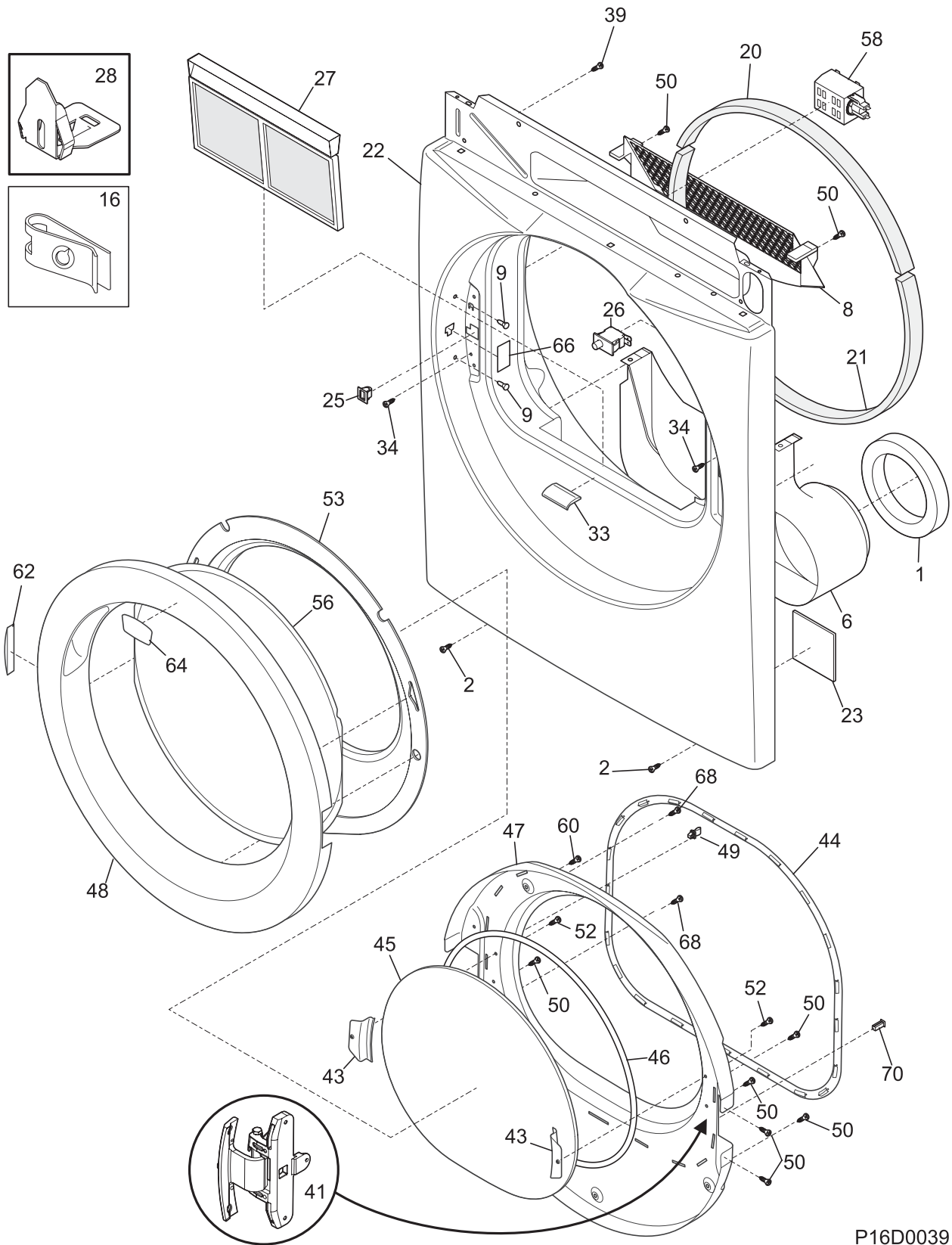

P16D0039

FRONT PANEL/LINT FILTER

POS. NO	PART NO.	DESCRIPTION
1	134417000	Seal, air duct
2	131168200	Screw, pan head, 8-18B x 0.31
6	134382900	Duct, air
8 #	131845845	Cover, lint housing, w/moist sensor
9	131633204	Plug, gray
16	134440100	Clip, U-nut
20	134440200	Seal, felt, upper
20*	5308027429	• Adhesive, high temp
21	134134700	Seal, felt, lower
22	134684360	Panel, front, black, w/lamp hole
23	131744202	Damper, vibration
25	134548045	Latch, door, gray, lower
26 #	131843145	Switch, door, with drum light
27	131450345	Trap, lint blade assy, gray
28	134440000	Clip, guide
33	134737245	Guide, door, gray
34	131243700	Screw, pan head, 8-18AB x 0.375
39	131205100	Screw, #8 pan head, 10-10B x 0.500, cr/sq drive
41	134680900	Hinge, door
43	134559300	Bracket, door glass
44	134720900	Gasket, door seal
45	134611800	Glass, inner door
46	134580300	Gasket, door glass, inner
47	134683940	Panel, inner door, gray
48	134854300	Panel, outer door, chrome
48*	134554500	Pad, outer door
49	134548100	Door Strike
50	131303300	Screw, pan head, 10-16AB x 0.500, locking
52	134529600	Screw, indt pan head, 8-18AB x 0.375
53	134558600	Ring, door transition
56	134550600	Glass, outer door lens
58 #	131843500	Lamp Assy, drum light, w/mtg bracket
58*#	131862800	• Lamp
60	134430300	Screw, indt pan head, 10-14 x 0.625, quadrex
62	134680760	Plug, hinge cutout, natural
64	134601625	Nameplate, Affinity, chrome
66	134680801	T-Plug, hinge hole
68	134742001	Plug, hinge hole, gray
70	134417501	Plug, rectangular, gray

CONTROLS/TOP PANEL

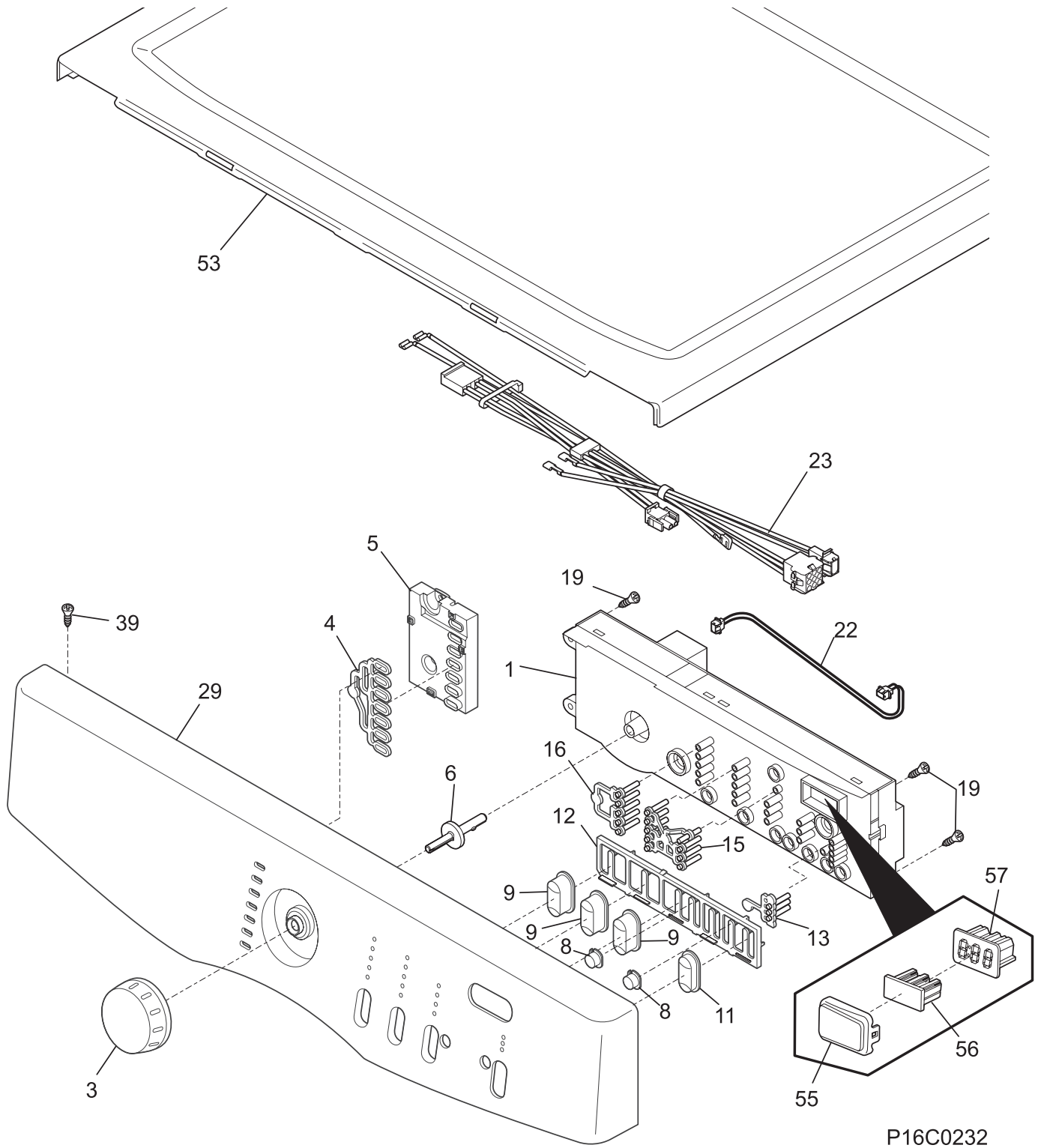

CONTROLS/TOP PANEL

POS. NO	PART NO.	DESCRIPTION
1 #	134557200	Control Board, printed circuit, with housing
3	134551225	Knob, program, chrome
4	134553100	Light Pipe, program
5 #	134556500	Interface Board, pc, auxiliary
6	134347700	Pin, program knob
8	134555525	Push Button, round, #1
9	134553425	Push Button, oval, #1
11	134864400	Push Button, oval, start
12	134884900	Spring, push button
13	134557501	Light Pipe, start group
15	134552800	Light Pipe, 5 x 4
16	134600000	Light Pipe, row of 5
19	134402900	Screw, phillips, 6-19 x 0.650
22 #	134602100	Wiring Harness, interface board
23 #	134720000	Wiring Harness, controls
23*#	134394200	Wiring Harness, main
29	134557060	Panel, control console, black
39	134178901	Screw, 8-18AB x 0.455
53	134365060	Panel, work top, black
55	134553200	Lens, digital display
56	134557300	Light Pipe, digital display
57 #	134503300	Display, digital

MOTOR

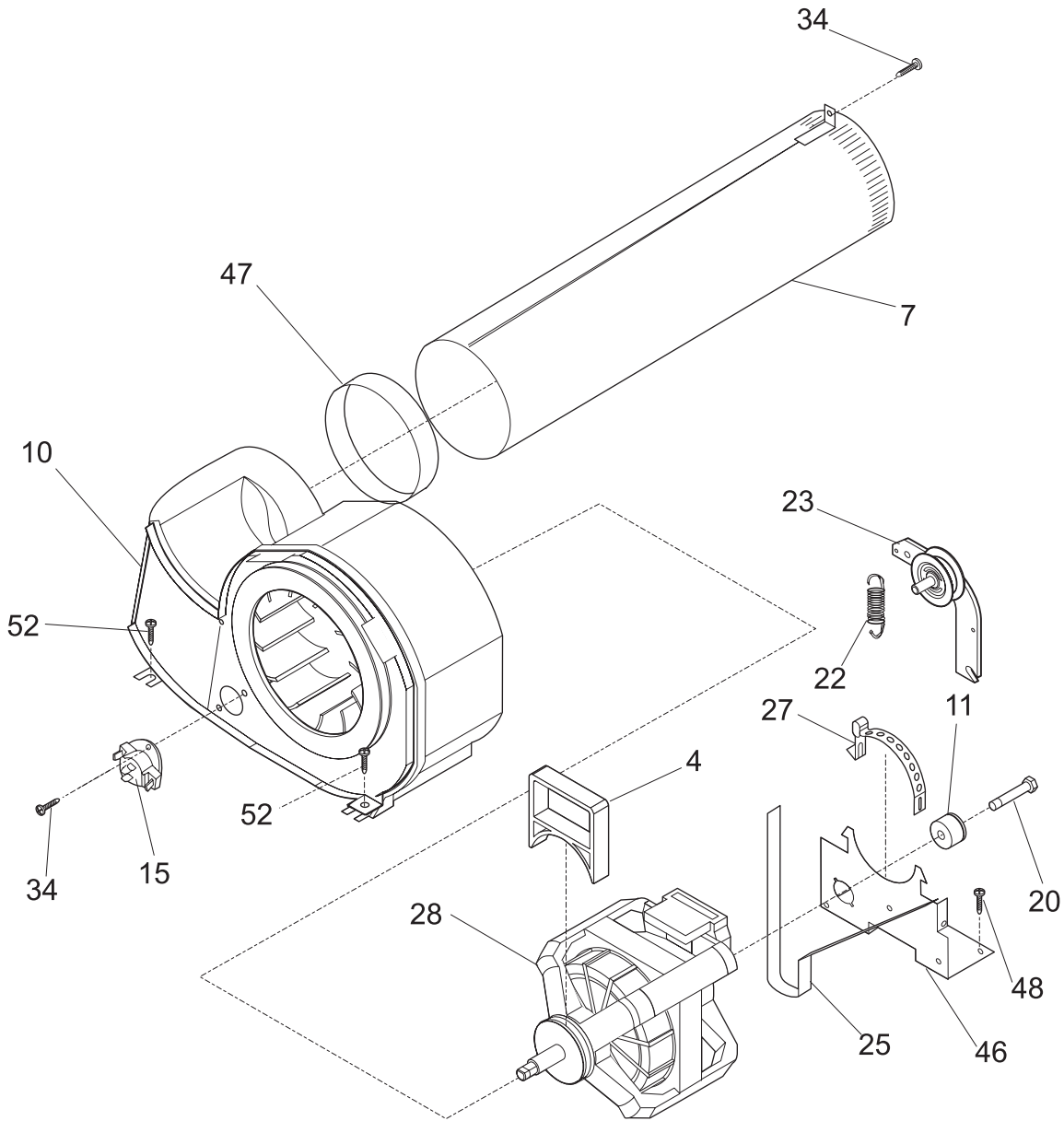

P16M0024

MOTOR

POS. NO	PART NO.	DESCRIPTION
4	131435200	Lock, blower housing
7	131451600	Tube, exhaust, rear, w/mtg bracket
7*	131456800	Tube, exhaust, side/bottom, Optional Kit
10 #	131775600	Blower Assy, housing, w/cover & wheel
11	131749800	Spacer, idler
15 #	134587700	Thermistor, control
20	131017900	Screw, hex head, 1/4-20T x 1.25, spacer mtg., thread cutting
22	131601000	Spring, idler arm
23 #	131863007	Idler Arm Assy, w/pulley
25 #	134503600	Belt, dryer
27	134242400	Clamp, motor mtg.
28 #	131560100	Motor & Pulley Assy
34	131243700	Screw, pan head, 8-18AB x 0.375
46	134203400	Bracket, motor mtg
47	131633300	Seal, exhaust tube
48	131168200	Screw, pan head, 8-18B x 0.31
52	131202300	Screw, 10-16AB x 0.625

WIRING DIAGRAM

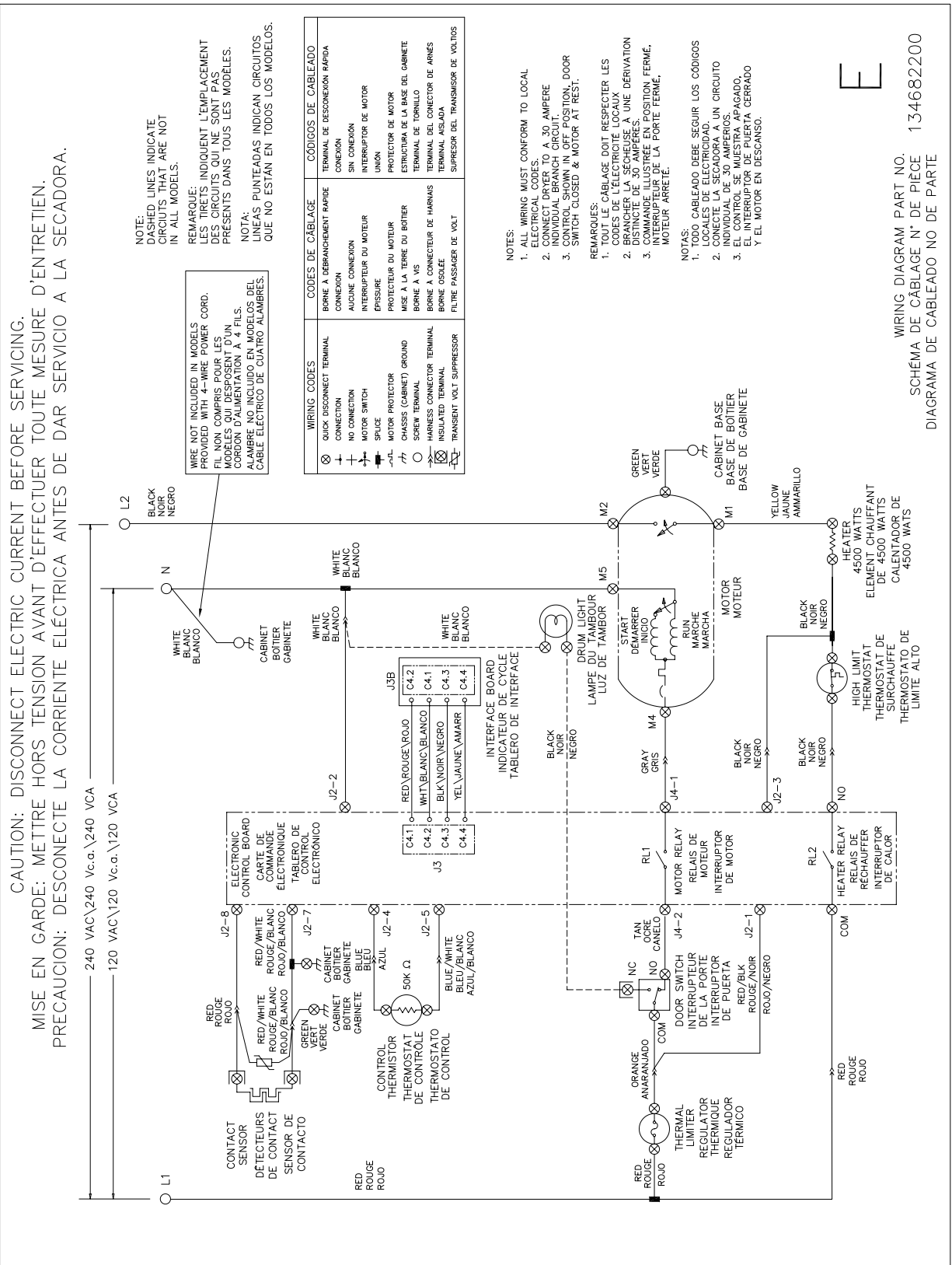

WIRING DIAGRAM

