

INSTALLATION INSTRUCTIONS

BUILT-IN GAS OUTDOOR WOK/COOKER VGWT - "T" SERIES

Retain for Future Reference

VIKING RANGE CORPORATION
111 Front Street
Greenwood, Mississippi 38930 USA
(662) 455-1200



IMPORTANT: PLEASE READ AND FOLLOW

1. Before beginning, please read these instructions completely and carefully.
2. Do not remove permanently affixed labels, warnings, or plates from product. This may void the warranty.
3. Please observe all local and national codes and ordinances.
4. Please ensure that this product is properly grounded.
5. **The installer should leave these instructions with the consumer who should retain for local inspector's use and for future reference.**

Installation must conform with local codes or in the absence of codes, the National Fuel Gas Code, ANSI Z223.1-latest edition.

IN CANADA: Installation must be in accordance with the current CAN/CGA-B149.1, Natural Gas Installation Code or CAN/CGA-B149.2, Propane Installation Code and/or local codes.

FOR YOUR SAFETY

If you smell gas:

1. **Shut off gas to the appliance**
2. **Extinguish any open flame**
3. **Open cover.**
4. **If odor continues, immediately call your gas supplier or your fire department**

FOR YOUR SAFETY

1. **Do not store or use gasoline or other flammable vapors and liquids in the vicinity of this or any other appliance.**
2. **An LP cylinder not connected for use shall not be stored in the vicinity of this or any other appliance.**

WARNING

If not installed, operated and maintained in accordance with the manufacturer's instructions, this product could expose you to substances in fuel or fuel combustion which can cause death or serious illness and which are known to cause cancer, birth defects, or other reproductive harm.

For example, benzene is a chemical which is part of the gas supplied to the cooking product. It is consumed in the flame during combustion. However, exposure to a small amount of benzene is possible if a gas leak occurs. Formaldehyde and soot are by-products of incomplete combustion. Properly adjusted burners with a bluish rather than yellow flame minimize incomplete combustion.

GENERAL INFORMATION

1. **WARNING:** This wok/cooker is not intended to be installed in or on recreational vehicles and/or boats.
2. **WARNING:** Keep any electrical supply cord and the fuel supply hose away from any heated surfaces.
3. Keep the wok/cooker area clear and free from combustible materials, gasoline, and other flammable vapors and liquids.
4. When the wok/cooker is not in use, the gas supply must be turned off at the LP gas supply cylinder.
5. The pressure regulator and hose assembly supplied with the wok/cooker must be used. Replacement pressure regulators and hose assemblies must be those specified by the manufacturer.
6. Finding a leak is not a "do-it-yourself" procedure. Some leaks can only be found with the burner control in the "on" position and this must be done by a qualified technician.
7. The LP supply cylinder to be used must be constructed and marked in accordance with the specifications for LP gas cylinders of the U.S. Department of Transportation (DOT) or the National Standard of Canada, CAN/CSA-B339, *Cylinders, Spheres, and Tubes for the Transportation of Dangerous Goods*.
8. Gas Manifold Pressure:
 - Natural gas - 4.0" W.C.P.
 - LP/Propane - 10.0" W.C.P.

CABINET CUTOUT DIMENSIONS

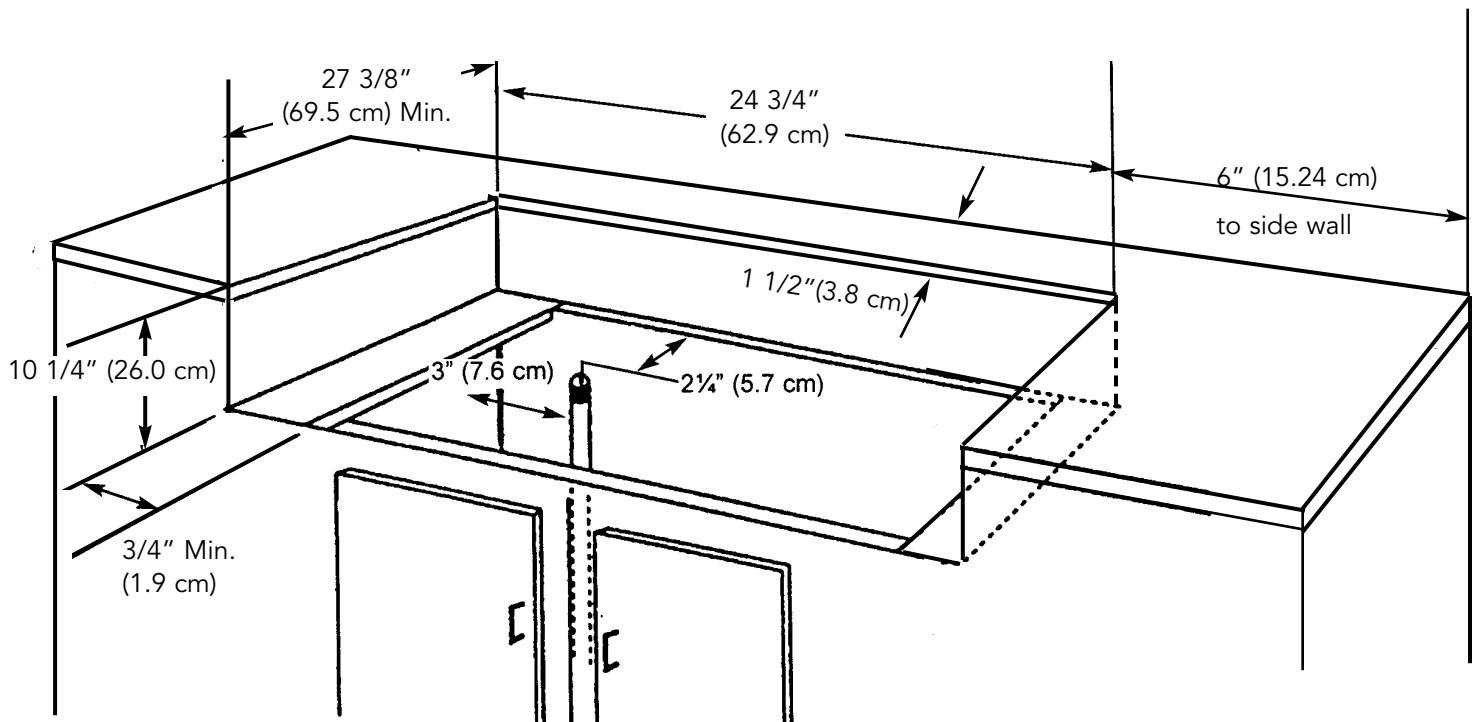

PROXIMITY TO CABINET INSTALLATION

The unit may be installed directly adjacent to the existing base cabinets. **IMPORTANT** - The side trim **MUST** be 3/8" (.95 cm) above the adjacent base cabinet countertop. There is a 0" side and rear clearance to non-combustible surfaces. The unit **CANNOT** be installed directly adjacent to combustible sidewalls. There must be a minimum of 6" (15.2 cm) side and rear clearance from the unit to such combustible surfaces. This unit can not be placed under an overhead which is unprotected and combustible.

GAS CONNECTION

Verify the type of gas supply to be used, either natural or LP/Propane and make sure the marking on the wok/cooker rating plate agrees with that of the supply. Never connect an unregulated gas line to the appliance. An installer supplied gas shut-off valve must be installed in an easily accessible location. All installer supplied parts must conform to local codes, or in the absence of local codes, with National Fuel Gas Code, ANSI Z223.1-latest edition. Installation in Canada must be in accordance with the current CAN/CGA-B149.1, Natural Gas Installation Code or CAN/CGA-B149.2, Propane Installation Code and/or local codes.

All pipe sealants must be an approved type and resistant to the actions of LP gases. Never use pipe sealant on flare fittings. All gas connections should be made by a competent technician and in accordance with local codes and/or ordinances. In the absence of local codes, the installation must comply with the National Fuel Gas Code ANSIZ223.1-latest edition.

The wok/cooker and its individual shut-off valve must be disconnected from the gas supply piping system during any pressure testing of that system at test pressures in excess of 1/2 PSIG (3.5 kPa). The wok/cooker must be isolated from the gas supply piping system by closing its individual manual shut-off valve during any pressure testing of that system at test pressures equal to or less than 1/2 PSIG (3.5 kPa).

NATURAL OR LP/PROPANE FIXED PIPING CONNECTION

Connection: Standard Residential 1/2" (1.3 cm) gas service line -1/2" (1.3 cm) NPT male with 3/8" (.95 cm) flare adapter.

Operating Pressure: 4.0 W.C.P. Natural or 10.0" W.C.P. LP/Propane

Supply Pressure: 6" to 14" W.C.P. If in excess of 14" W.C.P., a step down regulator is required.

Check with your local gas utility company or with local codes for instructions on installing gas supply lines. Be sure to check on type and size of run, and how deep to bury the line. If the gas line is too small, the unit will not function properly. Any joint sealant must be an approved type and be resistive to the actions of natural or LP/Propane gas.

TO CONNECT WOK/COOKER DIRECTLY TO GAS LINE IN A CABINET INSTALLATION

First screw the brass 1/2" (1.3 cm) fitting of the regulator in to the 3/8" (.95 cm) brass flare adapter. Ensure that the regulator arrow points in the direction of the gas flow towards the unit and away from the supply. **DO NOT** use threading compound on the male end of the 1/2" (1.3 cm) NPT to 3/8" (.95 cm) flare adapter. Connect the regulator assembly to the grill unit by pulling back the coupler sleeve towards the regulator. Insert the fitting on the grill unit into the coupler. Release the sleeve and continue pushing the fitting into the coupler until the sleeve snaps forward securing the connection.

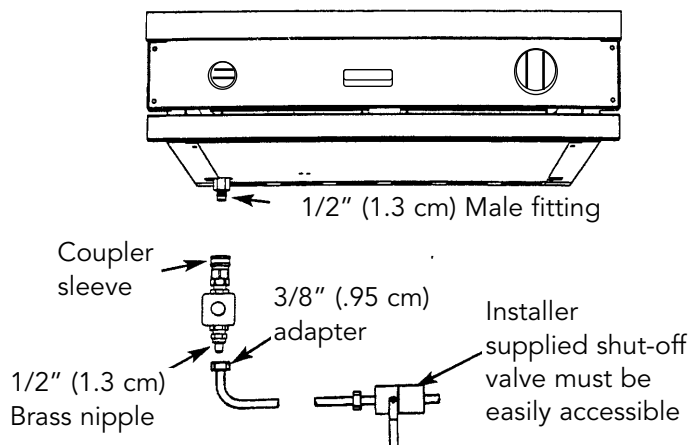

LP/PROPANE GAS CYLINDER CONNECTION

Outdoor wok/cookers orificed for use with LP/Propane cylinder gas come equipped with a high capacity hose/regulator assembly for connection to a standard 20 lb. LP/Propane cylinder **equipped with a Type 1, QCC-1 connector.** (See LP/Propane tank requirements)

Connection: 1/2" (1.3 cm) NPT male with a 3/8" (.95 cm) flare adapter

Operating Pressure: 10.0" W.C.P.

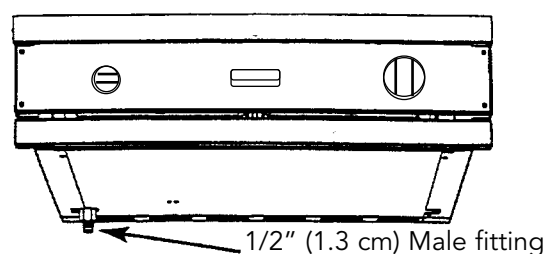

TO CONNECT DIRECTLY TO THE LP/PROPANE REGULATOR/HOSE ASSEMBLY IN A CABINET INSTALLATION

Although the flow of gas is stopped when the quick disconnect system is disconnected as part of its safety feature, you should always turn the LP/Propane tank main valve off after each use and during transport of the tank or unit. First connect the regulator to the grill unit by pulling back the coupler sleeve towards the regulator and inserting the 1/2" (1.3 cm) fitting into the coupler. Release the sleeve and continue pushing the inlet into the coupler until the sleeve snaps forward securing the connection. Then connect the hose assembly to the LP/Propane tank by screwing the Type 1, QCC-1 connector to the LP/Propane tank connector. Turn the main tank valve on and turn the burner control valve on the unit to any position for about 20 seconds to allow the air in the system to purge before attempting to light the burner.

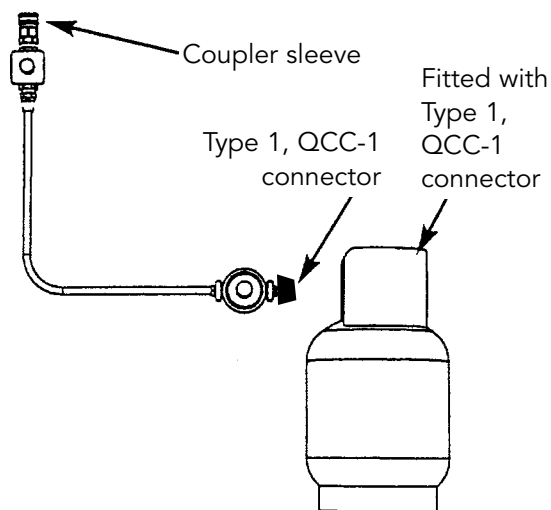

NOTE: INSPECT THE HOSE BEFORE EACH USE. IF IT IS EVIDENT THERE IS EXCESSIVE ABRASION, WEAR OR THE HOSE IS CUT, IT MUST BE REPLACED PRIOR TO USE.

BEFORE PLACING THE UNIT INTO OPERATION, ALWAYS CHECK FOR GAS LEAKS WITH A SOAPY WATER SOLUTION OR OTHER ACCEPTABLE METHOD. DO NOT USE AN OPEN FLAME TO CHECK FOR LEAKS!!! LEAK TESTING OF THE APPLIANCE SHALL BE CONDUCTED ACCORDING TO THE MANUFACTURER'S INSTRUCTIONS.

LP/PROPANE TANK REQUIREMENTS

A dented or rusty LP/Propane tank may be hazardous and should be checked by your LP/Propane supplier. Never use a cylinder with a damaged valve. All tanks should be equipped with an OPD (overfilling protection device). This is a DOT requirement for all tanks purchased after October 1, 1998, and will ensure that the tank is not overfilled. The LP/Propane tank should be a standard 5-gal., 20 lb. gas cylinder tank approximately 12" (3.1 cm) in diameter and 18" (45.7 cm) high which must be constructed and marked in accordance with the specifications for LP/Propane gas cylinders of the U.S. Department of Transportation (DOT) and designed for use with a Type 1, QCC-1 system only. The cylinder must be provided with a shut-off valve terminating in an LP/Propane gas supply cylinder valve outlet specified, as applicable, for a Type 1, QCC-1 connection. The cylinder used must include a collar to protect the cylinder valve. The cylinder supply system must be arranged for vapor withdrawal and provided with a listed overfilling prevention device. If the appliance is stored indoors the cylinder must be disconnected and removed from the appliance. Cylinders must be stored outdoors in a well-vented area out of the reach of children.

INITIAL IGNITION OF BURNERS

All appliances are tested before leaving the factory. Field adjustments may be necessary for proper mixture of gas and air for proper operation. When the unit is connected to gas and electrical service, it should be adjusted by a qualified technician. If it is not, contact your dealer for the name of their authorized service agency. If none are available, contact Viking Range Corporation for the nearest authorized service agency in your area.

BURNER ADJUSTMENTS

To gain access to the burner for adjustments:

1. Remove the grate and grate support.
2. Locate the air shutter "A" and loosen the two screws "B" that holds the air shutter in place.
3. Light the burner and turn the burner knob to the high position.
4. With a proper, high flame height, adjust the air shutter to obtain a blue flame with no yellow tipping that sits on the burner at the burner ports.
 - (a) open the air shutter gap to add more air and to eliminate yellow tipping.
 - (b) close the air shutter gap to reduce the air and to prevent a noisy flame that lifts off the burner.
5. Turn the surface burners off.
6. Tighten the air shutter screws.
7. Replace the grate support and grate.

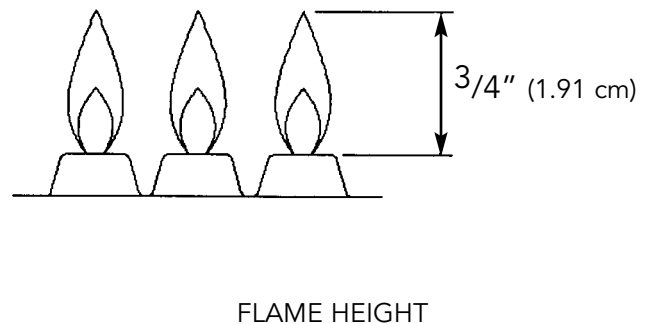
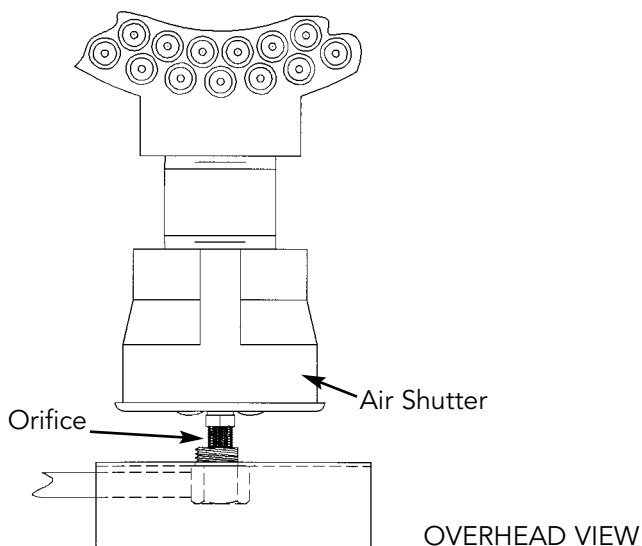
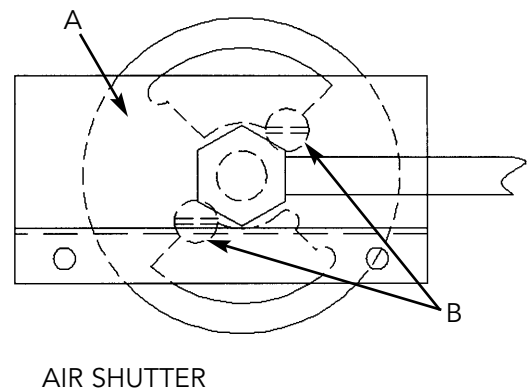

Viking Range Corporation
111 Front Street • Greenwood, Mississippi 38930 USA • (662) 455-1200

Specifications subject to change without notice

For more product information, call 1-888-VIKING1 (845-4641), or visit our web site at <http://www.vikingrange.com>.

F20094D

(PS0504VR)