

Danby

Silhouette

**OWNER'S MANUAL
GUIDE D'UTILISATION
MANUAL DEL
PROPIETARIO**

**Model • Modèle• Modelo
DKC646BLS**

CAUTION:

Read and follow all safety rules and operating instructions before first use of this product.

PRÉCAUTION :

Veillez lire attentivement les consignes de sécurité et les instructions d'utilisation avant l'utilisation initiale de ce produit.

PRECAUCIÓN:

Lea y observe todas las reglas de seguridad y las instrucciones de operación antes de usar este producto por primera vez.



Danby

Silhouette

Keg Cooler

Owners Manual

Table of Contents 3

Glacière de bière pression

Guide d'utilisation

Table des matières23

Barril Refrigerador

Manual del propietario

Tabla de Contenido43

WELCOME

Welcome to the Danby family. We're proud of our quality products and we believe in dependable service.

You'll see it in this easy-to-use manual and you'll hear it in the friendly voices of our consumer service department.

Tel: 1-800-26-**Danby**

Best of all, you'll experience these values each time you use your Keg Cooler. That's important, because your new Keg Cooler will be part of your family for a long time.

Start Here!...Before using your Keg Cooler

Write down the model and serial numbers here. They are on a label located on the back of the cabinet.

Staple your receipt to the inside back cover of this page. You will need it to obtain service under warranty.

Model number **DKC646BLS**

Serial number _____

Date purchased _____

NEED HELP?

Before you call for service, there are a few things you can do to help us serve you better...

Read this manual

It contains instructions to help you use and maintain your keg cooler properly.

If you received a damaged appliance

Immediately contact the dealer (or builder) that sold you the appliance.

Save time and money

Check the section titled "If Something Goes wrong" before calling. This section helps you solve common problems that might occur. If you do need service, you can relax knowing help is only a phone call away.

Tel: 1-800-26-**Danby**

TABLE OF CONTENTS

Important Safety Information

Grounding Instructions	4
Warning CO ₂ Can be Dangerous!	4
Safety Precautions	5
Don't Wait Do This Now!	5
Important Notice	5

4

Features

Knowing your Keg Cooler	6
Accessories	7
Capacity	8

6

Setting Up Your Keg Cooler

Before putting your appliance into use	9
Disposal of Packaging	9
Location	9
Outdoor Instructions	9
Assembly Instructions	10
Changing the Direction of the Door Swing	13
Castor Installation	13

9

Operation Instructions

Electronic Controls	14
Beer Temperature	14
Replace an Empty CO ₂ Cylinder	15
Tap a Keg	15
Using Proper Draw Technique	16

14

Cleaning and Maintenance

Keg Cooler, Dispense System	17
Glassware, CO ₂ Pressure, Beer Keg	18

17

Before You Call For Service

Troubleshooting	19
Warranty	20

19

IMPORTANT SAFETY INFORMATION

READ ALL SAFETY INFORMATION BEFORE USING

GROUNDING INSTRUCTIONS

FOR YOUR SAFETY...

Pertaining to the risk of Fire, Electric Shock or Injury to Persons.

- This appliance must be grounded. In the event of a malfunction or breakdown, grounding will reduce the risk of electric shock by providing a path of least resistance for electric current.
- This appliance is equipped with a power cord having an equipment grounding conductor and grounding plug. The plug must be plugged into an appropriate wall outlet that is installed and grounded in accordance with all existing local codes and ordinances.
- Consult a qualified electrician or serviceman if the grounding instructions are not clearly understood, or if doubt exist as to whether your electrical wall outlets are properly grounded.

WARNING CO₂ CAN BE DANGEROUS!

CO₂ Cylinders when charged contain high pressure compressed gas which can be hazardous if not handled properly. Read and understand the following procedures for CO₂ cylinders before installation;



WARNING



If it becomes difficult to breathe and/or your head starts to ache, abnormal concentrations of carbon dioxide (CO₂) may be present in the area....

CLOSE THE MAIN VALVE ON THE CO₂ CYLINDER, VENTILATE AND LEAVE THE ROOM IMMEDIATELY!

1. Always connect a CO₂ gas cylinder to a regulator. Failure to do so could result in an explosion which can possibly result in death or injury when the cylinder valve is opened.
 2. Never connect a CO₂ gas cylinder directly to beer keg.
 3. Always secure a CO₂ gas cylinder in an "upright" position.
 4. Always keep a CO₂ gas cylinder away from heat.
 5. Never drop or throw a CO₂ gas cylinder.
 6. Always check the D.O.T. (Department of Transport) test date located on the neck of the cylinder before installation. If over five (5) years, do not use, return the gas cylinder to gas supplier.
 7. Never connect a product container unless there are two (2) safety mechanism's in the pressure system;
 - (a) One at or on the CO₂ regulator.
 - (b) One at or on the product container coupler in the pressure gas line.
- NOTE:** *The regulator and keg coupler supplied with this unit are inclusive of such safety mechanisms.*
8. CO₂ gas cylinders should be stored in the coolest part of the establishment (preferably) at 70°F (21°C) and must always be securely fastened in an "upright" position.
 9. Always ventilate area after any leakage of CO₂.

IMPORTANT SAFETY INFORMATION

SAFETY PRECAUTIONS

- This appliance must be connected to a properly grounded electrical outlet (*see Grounding Instructions on pg. 4*)
- Do not operate this appliance if it has a damaged power cord or plug.
- Do not use this product near water, for example: in a wet basement, near a swimming pool or sink.

- Do not defrost this appliance using other electric appliances (i.e. hair dryer) and never attempt to scrape or remove ice/frost from the evaporator (cold plate) with sharp objects.
- Always disconnect the appliance from the power supply before cleaning and/or attempting repairs/servicing.

WARNING: Repairs should be performed by qualified service personnel only.

DON'T WAIT, DO THIS NOW!

Improper disposal of worn out appliances pose a risk of entrapment to children.

- If you have purchased this appliance to replace an old one remove either the gaskets, latches, lids or doors from the unused appliance. If it was equipped with a door lock that cannot be opened from the inside, (lock bolt) make sure the lock is removed, disabled or destroyed before discarding, this will make it impossible for children to accidentally lock themselves inside the appliance and suffocate.
- The refrigerator system of this appliance is filled with refrigerant and insulating substances which should be treated and processed separately. Call your nearest service agent or specialized servicing center. If you are unable to locate one, contact your local authorities for proper disposal instructions. Be careful not to damage any of the refrigeration lines of the appliance.

IMPORTANT NOTICE

Beer is easily available with Danby's new Keg Cooler, however, it is not intended to be available to people under the legal age to consume beer. A beer faucet lock kit for the purpose of limiting access, is readily available and can be purchased through our after sales service department (*see 'Optional Accessories' on pg 7*). Danby does not assume liability for the unlawful use or consumption of the beer.

PLEASE DRINK RESPONSIBLY AND PLEASE DON'T DRINK AND DRIVE!

FEATURES

KNOWING YOUR KEG COOLER

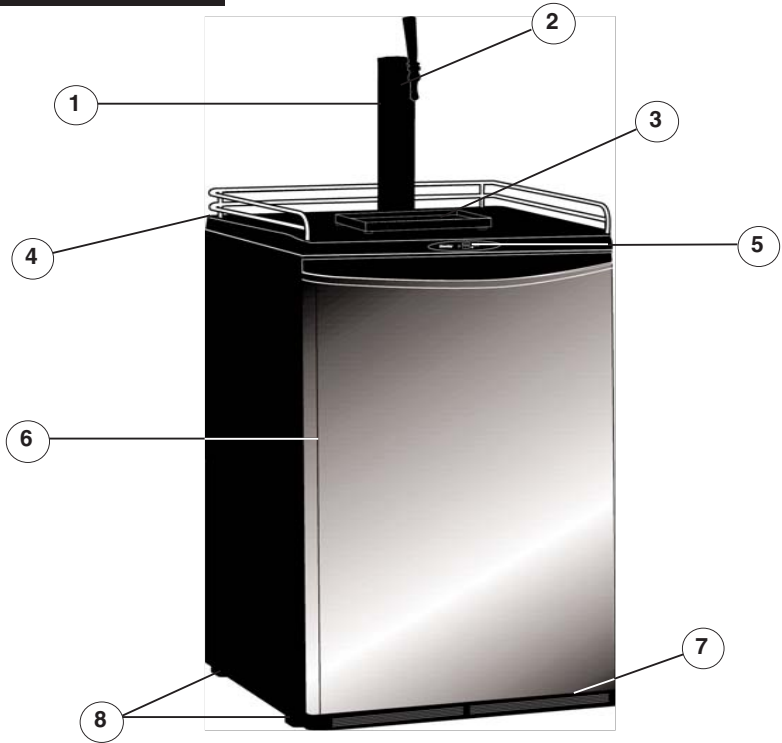

**1 Black
Dispense Tower**

**2 Dispenser
Faucet & Handle**

3 Plastic Drip Tray

**4 Worktop &
Chrome Rail**

**5 Electronic
Controls/Display**

**6 Stainless Steel
Door**

**7 Intake/Exhaust
(for condenser fan)**

8 Swivel Castors

FEATURES

INCLUDED ACCESSORIES

Remove and inspect all accessories supplied with this unit are present and in good condition. In the event any of the accessories are missing and /or not in good condition, please call Danby TOLL FREE at the number listed below and speak with one of our Customer Service Representatives.

- 2 Chrome Rails (for attachment to Work top)
- 4 Self-Tapping Screws (to attach chrome rails)
- 1 CO₂ Cylinder Support Stand
- 1 CO₂ Cylinder (empty)
- 1 CO₂ Regulator (high/low pressure gauges)
- 1 CO₂ Air Line Hose
- 2 CO₂ Air Line Hose Connectors
- 1 CO₂ Air line hose plug
- 1 Beer Keg Coupler
- 1 Beer Tower Unit (incl. faucet, hose, nut and rubber washer)
- 4 Machine Screws (to attach to beer tower)
- 1 Gasket (beer tower base)
- 1 Pull Handle (beer tower faucet)
- 1 Protective Plate (refrigerator cabinet floor)
- 1 Plastic Drip Tray (2 piece)
- 4 Swivel Castors - 2 locking
- 16 Machine screws (for castor installation)

OPTIONAL ACCESSORIES

These are NOT included with the Keg Cooler, and must be purchased separately.

Description

Beer Faucet Lock.
Beer Line Cleaning Kit.

Part No.

#7703
#CLEANINGKIT

For more details on purchasing any of the above listed accessories, please contact our customer service department at 1-800-26- **Danby**[®] (1-800-263-2629).

FEATURES

KEG SIZES

There are three (3) standard size beer kegs that can be used in your Keg Cooler;

1/2 Barrel: 58.5 Liter Keg (15.5 Gal)
Yields: 7 cases (1984ozs) of beer
Keg Weight: 170lbs Full (approx.)

1/4 Barrel: 30 Liter Keg (7.75 Gal)
Yields: 3-1/2 cases (992ozs) of beer
Keg Weight: 85lbs Full (approx.)

1/6 Barrel: 20 Liter Keg (5 Gal)
Yields: 2-1/2 cases (640ozs) of beer
Keg Weight: 60lbs Full (approx.)

CO₂ CYLINDER

A fully charged (5lb) CO₂ cylinder will service (approx.):

<u>Quantity</u>	<u>Keg Size</u>
10	58.5 Liter Kegs (1/2 Barrels)
20	30 Liter Kegs (1/4 Barrels)
25	20 Liter Kegs (1/6 Barrels)

For the location of a CO₂ supplier in your area, (re-fills) please look in your "Yellow Page" telephone directory under "OXYGEN" suppliers.

SETTING UP YOUR KEG COOLER

IMPORTANT:

- Ensure that all included accessories are present and in good condition (see *'Included Accessories on pg. 7*).
- Make sure you have read and understood all important safety information on pages 4-5.

Before putting the appliance into use...

If the appliance has recently been transported or tipped, before connecting the appliance to any electrical power supply, leave it standing (upright) for about 1 hour. This will reduce the possibility of malfunctions in the cooling system due to transport handling. Clean the appliance thoroughly, both interior and exterior. (See *'Cleaning and Maintenance' on pg. 17*)

DISPOSAL OF PACKAGING

WE CARE ABOUT THE ENVIRONMENT

- Our products use environmentally friendly (recyclable) materials. To this end, individual packaging materials are clearly identified with a recycling symbol. Always use proper disposal methods.
- When any appliance finally wears out, always use safe and proper disposal methods. (see *"DON'T WAIT, DO THIS NOW" on pg. 5*)

LOCATION

- Selecting the proper location will ensure peak performance levels of your appliance. Choose a location where the unit will not be exposed to heat emitting sources (e.g. a fireplace or a barbeque).
- This appliance is inclusive of a condenser fan cooled cabinet, the front intake and exhaust should have 2-3 inches clearance in order to maintain proper cooling.
- Do not use this product near water, for example: in a wet basement, near a swimming pool or sink.

OUTDOOR INSTRUCTIONS

IMPORTANT:

Do not operate the Keg Cooler outdoors unless all of the conditions outlined in this section and in the Important Safety Information section are fully satisfied.

Direct Sunlight

The Keg Cooler should not be exposed to direct sunlight. Keep the Keg Cooler shaded. Prolonged exposure to direct sunlight may increase cooling time and electricity consumption (energy costs).

Precipitation

The appliance should be covered (protected) from any precipitation.

Extreme Temperatures

Operate the Keg Cooler in ambient temperatures not less than 10°C / 50°F or greater than 40°C / 104°F.

SETTING UP YOUR KEG COOLER

ASSEMBLY INSTRUCTIONS

1. **Installation of the Top Rail:** See Fig. 1.

2. **Installation of CO2 Regulator:** Attach the CO2 Regulator to the CO2 cylinder by screwing the regulator nut onto cylinder valve and tighten (snug) using an adjustable wrench. See Fig. 2.

IMPORTANT NOTICE: ALWAYS EXERCISE EXTREME CAUTION WHEN HANDLING THE PRESSURIZED CO2 CYLINDERS.

3. **Installation of CO2 Cylinder:** Install your “fully charged” CO2 cylinder into the support stand.

4. **Installation of CO2 Cylinder Support:** Align the holes in the cylinder support stand with the studs and push down firmly. See Fig. 3.

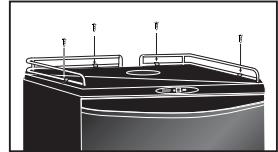

Fig. 1



Fig. 2

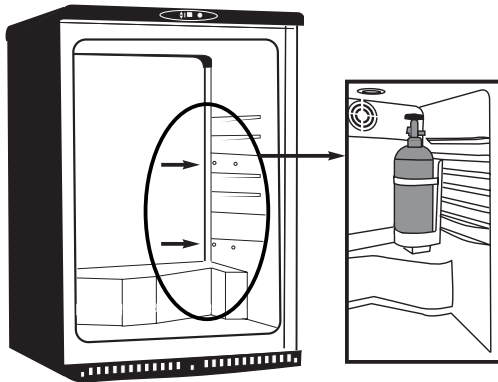

Fig. 3

SETTING UP YOUR KEG COOLER

ASSEMBLY INSTRUCTIONS (CONT'D)

5. Installation of CO₂ Air Line Hose to Regulator:

Attach one end of the (red) air line hose to the hose barb connection on the CO₂ regulator.

Secure hose by using one of the two (self locking) black plastic snap on clamps provided. (use pliers to snap the clamp tight to ensure that there are no leaks) **See Fig. 5**

6. Installation of the Beer Tower Gasket:

Position the rubber (beer tower) gasket directly on top of the cabinet aligning all four holes in the gasket with the four holes on the cabinet.

7. Installation of the Beer Tower:

Unravel the beer line (hose) from the tower and insert the beer line and nut through the gasket and into the cabinet. Align the four holes in the base of the beer tower, gasket and bayonet. The beer faucet should be facing the front of the cabinet. (6:00 o'clock position) Using a Phillips Screwdriver, attach the beer tower to the cabinet using the four machine screws provided and tighten firmly.

8. Installation of the Beer Tower Faucet Handle:

Screw the black faucet handle (clockwise) onto the beer tower faucet. (hand tighten only)

9. Installation of the Keg Coupler: **IMPORTANT**

NOTICE; Make sure the pull handle of the keg coupler is in the "upward" (closed) position before installing on the beer keg. **See Fig. 6** Insert the keg coupler into the locking neck of the beer keg and apply a 1/4 turn clockwise to lock into position.

10. Installation of the CO₂ Air Line Hose to the Keg Coupler:

Attach the open end of the (red) air line hose to the hose barb connection on the keg coupler. Secure hose by using the remaining (self locking) plastic snap on clamp provided. (use pliers to tighten clamp and ensure there are no leaks)

11. Installation of the Beer Line Hose to the Keg Coupler:

Screw the beer line nut onto the keg coupler and hand tighten firmly. **IMPORTANT NOTICE:** The black rubber washer provided must be installed inside the beer line connection nut before connecting the beer line to the keg coupler.



Fig. 5

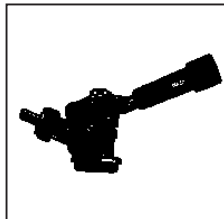

Fig. 6

SETTING UP YOUR KEG COOLER

ASSEMBLY INSTRUCTIONS (CONT'D)

13. Making the connection between the Keg

Coupler and Beer Keg: Before making (opening) connection between the keg coupler and beer keg, make sure the beer tower faucet is in the closed position. (faucet handle straight back) To engage the tank connection, pull the keg coupler handle out and push down until it locks into position. Listen for positive "click" of the pull handle in the final downward position. **See Fig. 7**

14. Opening the CO₂ Cylinder Main Valve:

Before opening the main valve located on top of the CO₂ cylinder, make sure the "secondary" shut-off valve located on the lower stem pipe of the regulator is in the "closed" position. **See Fig. 8**

NOTE: When the secondary valve (handle) is positioned "Horizontal" (east/west) the valve is closed. When the secondary valve (handle) is positioned "Vertical" (north/south) the valve is open. To open the main CO₂ cylinder valve, slowly turn the main valve counter clockwise until fully open. You will notice the needles on both gauges start to climb.

15. Adjusting the CO₂ Regulator:

There are two pressure gauges on the CO₂ regulator. **See Fig. 9:** The upper gauge #1 monitors "LOW" (internal keg) pressure and must be adjusted to the correct operating pressure of 10-12psi/lbs. The lower gauge #2 monitors "HIGH" (CO₂ cylinder) pressure and is not adjustable. The high pressure gauge also acts as a fuel gauge to let you know when the CO₂ cylinder needs re-filling.

IMPORTANT: The internal operating pressure of the beer keg should be adjusted and maintained between 10 ~ 12psi/lbs. To adjust the "low" pressure gauge;

- Using an adjustable wrench, release the adjustment lock nut # 3. **See Fig. 9**
- Using a flat screwdriver, turn the regulator adjustment screw (# 4 in Fig. 9): A clockwise rotation of the regulator adjustment screw will increase low pressure, a counter clockwise rotation of the adjustment regulator adjustment screw will decrease low pressure
- When the required operating pressure is attained retighten the adjustment lock nut # 3.
- You are now ready to serve cold beer

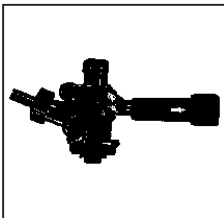

Fig. 7

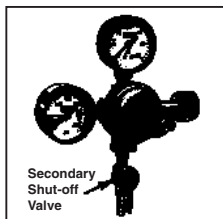

Fig. 8

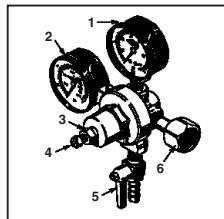

Fig. 9

SETTING UP YOUR KEG COOLER

Changing Direction of the Door “Swing”

IMPORTANT NOTICE: Before proceeding with the configuration options on this page, remove keg and the CO₂ cylinder (if installed) from the Keg Cooler. Once complete, allow the unit to stand upright for 1 hour before putting the unit into operation.

TOOLS REQUIRED: Phillips #2 screwdriver

WARNING!

Excessive Weight Hazard
Use two or more people to move and install the keg cooler.

IMPORTANT!

Allow the unit to stand upright for 1 hour before putting the unit into operation.

1. Unplug the keg cooler and place the unit on its back..
2. Remove the kickplate by removing the three retaining screws (Fig. E1)
3. Remove the four screws from the lower support (Fig.E2) and remove the lower support.
4. Pull the door downward until it releases from the upper hinge pin.

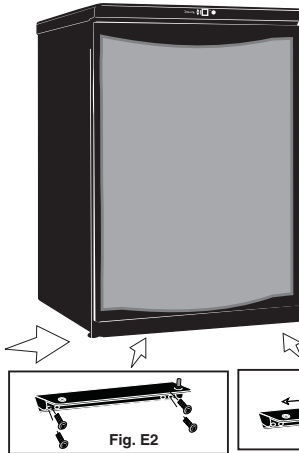
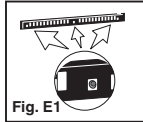

5. Remove the plastic screw caps from the top left hand side and install it on the top right hand side of the door frame.
6. Unscrew the upper door hinge pin (Fig E3) from the right side of the worktop Fig.E3 and install it on the left side of the worktop.
7. Position the main door on the cabinet and push up until the upper hinge pin is inserted into the top of the door.
8. Remove the lower support pin from the lower support and reposition it as shown in Fig. E4).
9. Reinstall the lower support pin on the lower right side of the door.

10. Make sure to align the door with 1) the cabinet, and 2) the lower support pin before reinstalling the bottom-plate and its four (4) screws.
11. Reinstall the kick-plate.

Castor Installation

The locking swivel castors should be installed in the front of the unit for easy access.

1. Lay the unit on it's back.
2. Using the 16 machine screws provided, install each of the 4 castors in the threaded holes located in each corner of the unit as shown in Fig.A.



Fig. A

OPERATING INSTRUCTIONS

Electronic Controls

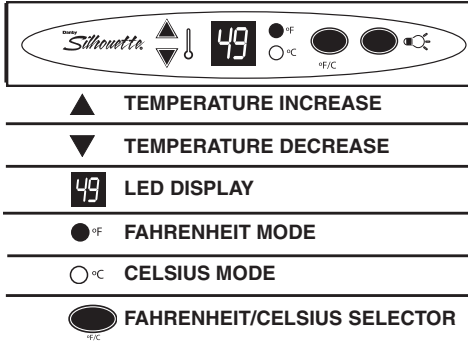

The electronic control panel allows for total cabinet temperature control as well as the option of displaying (current) and modifying (setting) the cabinet temperature in either Fahrenheit or Celsius.

When you first plug in your Keg Cooler the LED will display the 'live' cabinet temperature in Fahrenheit and the thermostat will be set to 41° F (5° C). The following paragraphs will explain how to modify the aforementioned settings to suit your requirements;

Adjusting the temperature;

- Press either ▲ or ▼ button once and release to enter the 'SET' mode. The LED display will begin to flash and show the previous temperature setting - signifying the temperature is ready to be adjusted.
- Each depression of the ▲ or ▼ will increase or decrease the temperature incrementally by 1° (F/C) until the desired setting is reached. The temperature can be set between 36-46° F (2-8° C).

**Note: the display will flash for 5 seconds from the time the last button was activated before resuming display of the internal temperature of the cabinet.*

Changing the temperature display;

- Press the  selector button to alternate the display between Fahrenheit and Celsius. The corresponding pilot light adjacent to the selector will illuminate to signify which unit of temperature has been selected for display.

** Please Note: In the event of a power failure, any modified settings are lost and the default settings are restored once power resumes.*

Beer Temperature

Correct consistent temperature is an important factor to consider when storing and dispensing draught beer. Therefore, please adhere to the following guide lines;

- Beer can freeze, so it is important to select and maintain proper operating temperatures inside the refrigerator cabinet. *** Beer will start to freeze at 28° F (- 2° C)**
- Optimum temperatures for serving cold beer are 36° ~ 40° F (2° ~ 4° C)
- Temperatures too cool or too warm may cause flavor loss, off taste and dispensing problems.
- Periodically monitor temperatures inside your keg cooler (adjust as necessary).
- Keep the keg cooler door closed as much as possible to avoid temperature fluctuations.

OPERATING INSTRUCTIONS

Replace an Empty CO₂ Cylinder

1. Close the main cylinder valve (A) by turning in a clockwise direction. **See Fig.12**
2. Close the secondary shut-off valve (C) by turning to "horizontal" (east/west) position on lower stem pipe. **See Fig.12**
3. Remove the air line clamp and hose from the regulator.
4. Remove the regulator assembly (E) from empty cylinder. **See Fig.12**
5. Remove dust cap from new and/or replacement CO₂ cylinder
6. Re-attach regulator assembly (E) to new/replacement cylinder. **See Fig.12**
7. Re-attach the air line hose to regulator (barb connection) and secure with clamp.
8. Slowly open main valve (A) all the way. **See Fig. 12**
9. Readjust regulator pressure (D) (if necessary) between 10 ~ 12 psi/lbs.
10. Open the secondary shut-off valve (C) by turning to "vertical" (north/south) position on lower stem pipe.

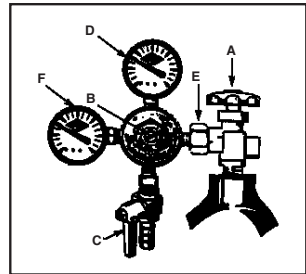

Fig. 12

Tap a Keg

IMPORTANT: Do not agitate kegs unnecessarily. If any agitation occurs (during transportation or installation) allow keg to settle for 1 ~ 2 hours before tapping.

- Prior to tapping the keg, ensure the beer faucet is in the off position.
- Completely remove the dust cover (identification cap) from the beer keg.
- Check that the keg coupler (handle) is in the up (off) position. **See Fig. 6**
- Insert the keg coupler into the locking neck of the beer keg and apply a turn clockwise to lock into position.
- Pull keg coupler handle out and downward until it locks into position. **See Fig. 7** This activates both the beer and (CO₂) pressure line.

The keg is now tapped and ready to draw beer.

OPERATING INSTRUCTIONS

Using Proper Draw Technique

Using the proper draw technique to dispense beer should allow you to fill an 8 oz glass leaving approximately 3/4" - 1" of 'foam'.

1. Rinse a "Beer Clean" glass under cold water.
2. Place glass beneath tap, and tilt at a 45° angle. (as shown in **Fig. 13**) Leaving approximately 1/4" between glass and faucet.
3. Fully draw the dispenser handle and fill the glass to 2/3 full. (as shown in **Fig. 14**).
4. Level the glass and finish topping off by continuing the pour in the center of the glass. (as shown in **Fig. 15**)
5. Make sure the handle is fully returned to it's previous 'off' position when the draw is complete.



Fig. 13



Fig. 14



Fig. 15

DO NOT.....

- Begin the draw with the glass in an upright position.
- Use frosted glassware, as the difference in temperature between a frozen glass and the beer in the keg can cause a 'wild' draw (too much foam).
- Partially (or slowly) draw the dispenser handle, this will lead to unnecessary turbulence in the dispenser faucet as the beer travels through it, causing a substantial amount of foam in the glass.



Fig. 16

CLEANING AND MAINTENANCE...

Regular cleaning and maintenance is a key factor in safe guarding the longevity of the keg, the quality of the dispensed beer as well as trouble free day to day operation of your Keg Cooler.

...of the Keg Cooler

- There is no need to defrost the refrigerator, because ice depositing on the evaporator is defrosted automatically. Ice build-up on the evaporator during compressor operation; will (when the compressor has cycled off) defrost automatically. Defrost water collects inside the drain trough and passes through the drain outlet in the rear wall into a drain pan situated above the compressor, where it evaporates.
- Always disconnect the power cord before cleaning and/or servicing the appliance. Do not use coarse or aggressive cleaning agents as they can damage the control panel and/or painted surfaces. Clean the exterior cabinet with warm water and a mild detergent. Clean the interior with warm water and a mild detergent, adding one or two spoonfuls of vinegar. After cleaning, connect the appliance to power supply.
- If you do not intend to use the appliance for long periods of time, disconnect the power cord. Clean the appliance and leave the door slightly open to reduce mold/mildew from accumulating inside the cabinet.

... of the Dispense System

Beer lines have to periodically be cleaned because of a crystallized build up which forms on the fittings, lines and taps commonly referred to as "beerstore". If the "beerstore" is not completely removed in a cleaning process it will leave an unsanitary surface that can harbor microorganisms which will cause an undesirable flavor and/or cause the beer to go flat. Sufficient "beerstore" will also lead to dispense problems ranging from 'wild' beer (too much foam) to flat beer, regardless of the carbonation levels or quality (age) of the beer in the keg.

Scheduled line and faucet cleaning, with the proper equipment and chemical, eliminates the build-up of "beerstore" protecting the integrity of the product and condition of the dispense system and seals. The dispenser (beer) line should be cleaned approximately once every three (3) weeks or every other keg - whichever ever comes first. The dispenser faucet should be cleaned on a weekly basis or prior to every use if not used on a regular basis. **Note:** If you have trouble manipulating the faucet lever, this is usually indicative that it may require cleaning. **DO NOT** apply force to move the handle in this situation, as this will likely lead to damaging the handle and/or faucet, and will not be covered by your warranty.

A standard cleaning kit will perform approximately eight (8) scheduled line cleanings. Line cleaning kits are readily available and can be purchased through our after sales service department. For more information please call 1-800 26-DANBY (1-800-263-2629)

CLEANING AND MAINTENANCE...

... of the “Beer Clean” Glassware

- Maintain strict sanitary conditions in the glass washing area.
- Never wash glassware with utensils or dishes used to serve food. Food particles and/or residue can effect the quality/taste of draught beer.
- Regular dish detergents are fat-based and will leave a slight oily film on the glass, which will cause the beer to go flat quickly. Therefore, it is highly recommended that you use a detergent that is designed specifically for beer glass cleaning which is odor-free and non-fat based, instead of regular liquid detergents.
- Avoid drying glassware with towels as they tend to leave traces of lint on the surface of the glass.
- We recommend that you use beer glassware only for beer. Dairy and other food products leave a residue which can effect the quality/taste of the draught.

... of the CO₂ Pressure

- Periodically monitor the pressure regulators to ensure applied operating pressures remain constant. (10~12psi/lbs)
- Always keep equipment in good repair.

... of the Beer Keg

Draught Beer should be treated as a food product.

It is very important that you store and handle it properly.

- Draught Beer should be immediately stored in a refrigerated cabinet.
- Draught Beer products have a shelf life, which on "average" is 30 days after the keg is tapped. By keeping the beer keg pressurized, (with CO₂) and with proper maintenance of the dispense system, the shelf life can be extended to approximately 60 days (or more).
- Beer Kegs should be stored (refrigerated) separately from other food products.

BEFORE YOU CALL FOR SERVICE

TROUBLESHOOTING

Problem	Possible Causes	What To Do
<i>Excess formation of foam 'head'.</i>	Recent keg agitation	If the keg has recently been moved (transported), you should let it stand for a minimum of two (2) hours before tapping.
	Improper regulator setting	Verify that the 'LOW' side (CO ₂) pressure is reading between 10 ~ 12 p.s.i.
	Internal temperature of keg cooler (or beer keg) too warm.	Ensure that the keg cooler is operating within 36 - 40° F (2-4° C). If the beer keg has been exposed to a warm environment for an extended period, give it sufficient time to cool before attempting a pour.
	Pressure build up	Activate the pressure relief valve that is located on the keg coupler for 3 seconds.
	Improper draw technique	see "Using Proper Draw Technique" on pg. 16.
<i>Flat Draft, no formation of foam.</i>	Improper regulator setting.	Verify that the 'LOW' side (CO ₂) pressure is reading between 10 ~ 12 p.s.i.
	Glassware is not "Beer clean"	Residue on glassware in the form of oils will quickly dissolve the formation of foam. (see "Beer Clean Glassware" on pg. 18)
	Elongated dispensing hose.	All recommended temperatures and gauge settings are calculated for a dispensing hose five (5) feet in length.
	Low/Empty CO ₂ cylinder.	Check that 'HIGH' pressure gauge is not reading "0" p.s.i. Refill if necessary.
<i>No beer flow from dispenser</i>	Closed CO ₂ valve and/or shut-off valve.	Ensure that both the CO ₂ cylinder and regulator shut-off valve are open.
	Empty CO ₂ cylinder.	Check that 'HIGH' pressure gauge is not reading "0" p.s.i. Refill if necessary.
	Empty beer keg.	Replace beer keg.
	Line or dispenser obstructions.	Verify that there are no 'kinks' or obstructions in either the air line (red) or dispenser line (clear) and that neither are frozen.
	Improper connection(s)	Ensure all connections are secure and all seals are in place and in good condition.

BEFORE YOU CALL FOR SERVICE

TROUBLESHOOTING (Cont'd)

Problem	Possible Causes	What To Do
<i>Sputtering draw</i>	Dispense system requires cleaning.	See "Cleaning and Maintenance" on pg. 17-18
	Keg Coupler installed incorrectly	Check seal between keg & faucet
	Line or dispenser obstructions.	Verify that there are no 'kinks' or obstructions in either the air line (red) or dispenser line (clear) and that neither are frozen.
	Improper draw technique	see "Using Proper Draw Technique" on pg. 16.
<i>Faucet Dripping</i>	Handle not fully returned to close position.	After every pour, ensure the handle is returned to the the off position.
	Faucet requires cleaning.	See "Cleaning and Maintenance" on pg. 17-18
<i>Rapid CO₂ cylinder discharge</i>	Improper connection, air line leak.	Ensure proper connection of air line at CO2 regulator, and/or check air line for possible leaks
<i>Difficulty Manipulating Faucet handle</i>	Faucet requires cleaning	See "Cleaning and Maintenance" on pg. 17-18
	Damaged handle stem	Remove handle, and connector nuts and inspect stem for possible damage.
<i>Abnormal beer taste and/or smell</i>	Dispense system requires cleaning.	See "Cleaning and Maintenance" on pg. 17-18
	Contaminated dispense system.	Check hoses for possible air leaks. Ensure all connections are secure and all seals are in place and in good condition.
	The beer has exceeded it's shelf-life.	Replace Beer Keg.

Danby

Silhouette

LIMITED PRODUCT WARRANTY

This quality product is warranted to be free from manufacturer's defects in material and workmanship, provided that the unit is used under the normal operating conditions intended by the manufacturer.

This warranty is available only to the person to whom the unit was originally sold by Danby or by an authorized distributor of Danby, and is non-transferable.

TERMS OF WARRANTY

Plastic parts (ie. evaporator door, door rails, covers and trays are warranted for thirty (30) days only from purchase date, with no extensions provided.

First Two Years During the first two years (2), any electrical parts of this product found to be defective, including any sealed system units, will be repaired or replaced, at warrantor's option, at no charge to the ORIGINAL purchaser. Consumable parts (ie. light bulbs) are not warranted or guaranteed for any length of time.

To obtain Service Contact your dealer from whom your unit was purchased, or contact your nearest authorized Danby service depot, where service must be performed by a qualified service technician. If service is performed on the unit by anyone other than an authorized service depot, or the unit is used for commercial application, all obligations of Danby under this warranty shall be at an end.

Nothing within this warranty shall imply that Danby will be responsible or liable for any spoilage or damage to food or other contents of this appliance, whether due to any defect of the appliance, or its use, whether proper or improper.

EXCLUSIONS

Save as herein provided, Danby Products Limited (Canada) or Danby Products Inc. (U.S.A.), there are no other warranties, conditions, representations or guarantees, express or implied, made or intended by Danby Products Limited or its authorized distributors and all other warranties, conditions, representations or guarantees, including any warranties, conditions, representations or guarantees under any Sale of Goods Act or like legislation or statute is hereby expressly excluded. Save as herein provided, Danby Products Limited (Canada) or Danby Products Inc. (U.S.A), shall not be responsible for any damages to persons or property, including the unit itself, howsoever caused or any consequential damages arising from the malfunction of the unit and by the purchase of the unit, the purchaser does hereby agree to indemnify and save harmless Danby Products Limited from any claim for damages to persons or property caused by the unit.

GENERAL PROVISIONS

No warranty or insurance herein contained or set out shall apply when damage or repair is caused by any of the following:

- 1) Power Failure.
- 2) Damage in transit or when moving the appliance.
- 3) Improper power supply such as low voltage, defective house wiring or inadequate fuses.
- 4) Accident, alteration, abuse or misuse of the appliance such as inadequate air circulation in the room or abnormal operating conditions, (extremely high or low room temperature).
- 5) Use for commercial or industrial purposes.
- 6) Fire, water damage, theft, war, riot, hostility, acts of God such as hurricanes, floods etc.
- 7) Service calls resulting in customer education.

Proof of purchase date will be required for warranty claims; so, please retain bills of sale. In the event warranty service is required, present this document to our AUTHORIZED SERVICE DEPOT.

Warranty Service

In Home

Danby Products Limited
P.O. Box 1778, Guelph, Ontario, Canada N1H 6Z9
Telephone: (519) 837-0920 FAX: (519) 837-0449

Danby Products Inc.
P.O. Box 669, Findlay, Ohio, U.S.A. 45839-0669
Telephone: (419) 425-8627 FAX: (419) 425-8629

03/08

Danby

Silhouette.

**Model • Modèle • Modelo
DCK646BLS**

For service, contact your nearest service depot or call:

**1-800-26- Danby®
(1-800-263-2629)**

to recommend a depot in your area.

En cas de réparation, veuillez contacter votre service après-vente le plus près ou communiquez au:

**1-800-26- Danby®
(1-800-263-2629)**

pour connaître le service après-vente le plus proche.

Para obtener servicio, comuníquese con el establecimiento de servicio más cercano o llame al:

**1-800-26- Danby®
(1-800-263-2629)**

para que le recomendemos un establecimiento de su zona.

Keg Cooler

The model number can be found on the serial plate located on the back panel of the unit.

All repair parts available for purchase or special order when you visit your nearest service depot. To request service and/or the location of the service depot nearest you, call the TOLL FREE NUMBER.

When requesting service or ordering parts, always provide the following information:

- Product Type
- Model Number
- Part Description

Glacière de bière en fût

Le numéro du modèle se trouve sur la plaque d'identification située sur le panneau arrière de l'appareil.

Il est possible d'acheter les pièces de rechange ou de les obtenir par commande spéciale en vous rendant à votre service après-vente le plus proche. Pour effectuer des réparations ou obtenir l'adresse du service après-vente le plus proche, veuillez composer le NUMÉRO SANS FRAIS.

Pour effectuer des réparations ou commander des pièces de rechange, veuillez donner les renseignements suivants :

- Type de modèle
- Numéro du modèle
- Description des pièces

Refrigerador de Barril

El número de modelo se encuentra en la placa de serie, ubicada en el tablero posterior de la unidad.

Puede comprar todos los repuestos o hacer un pedido especial visitando el establecimiento de servicio más cercano a su domicilio. Llame al TELÉFONO GRATUITO para obtener servicio de mantenimiento o la dirección del establecimiento de servicio más cercano a su domicilio.

Siempre, al solicitar servicio de mantenimiento o hacer un pedido de repuestos, debe suministrar la siguiente información:

- Tipo de artefacto
- Número de modelo
- Descripción del repuesto

Danby Products Limited, Guelph, Ontario Canada N1H 6Z9
Danby Products Inc., Findlay, Ohio USA 45840