

## UNDERCOUNTER CABINET CUTOUT

A	15" (38.1 cm)*
B	Min. 34 1/2" (87.6 cm) Max. 35 1/8" (89.2 cm)
C	Min. 24" (61.0 cm)

\*15" (38.1 cm) width for cabinet only. If door is recessed between cabinets, cabinet cutout must be 15 1/4" (38.7 cm).

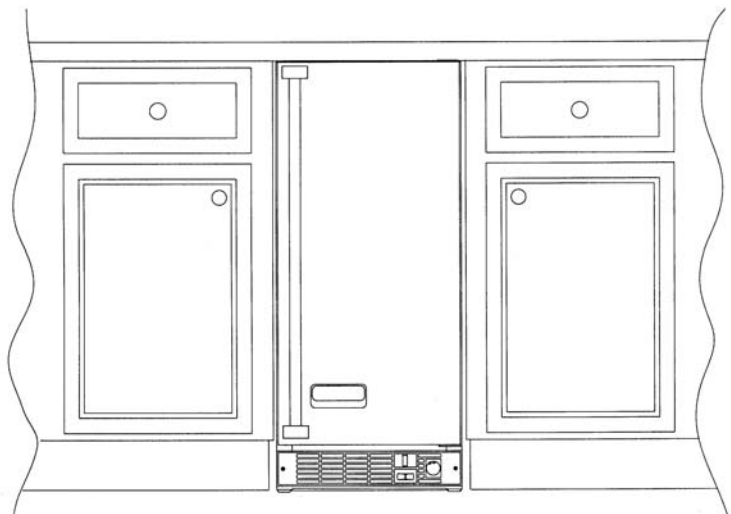
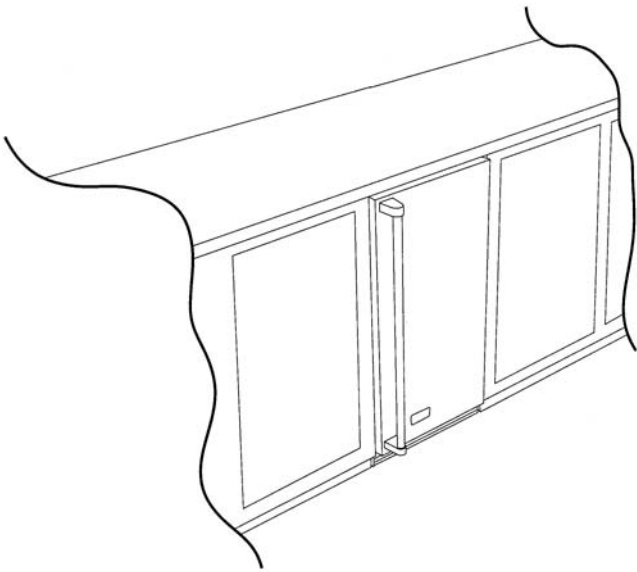
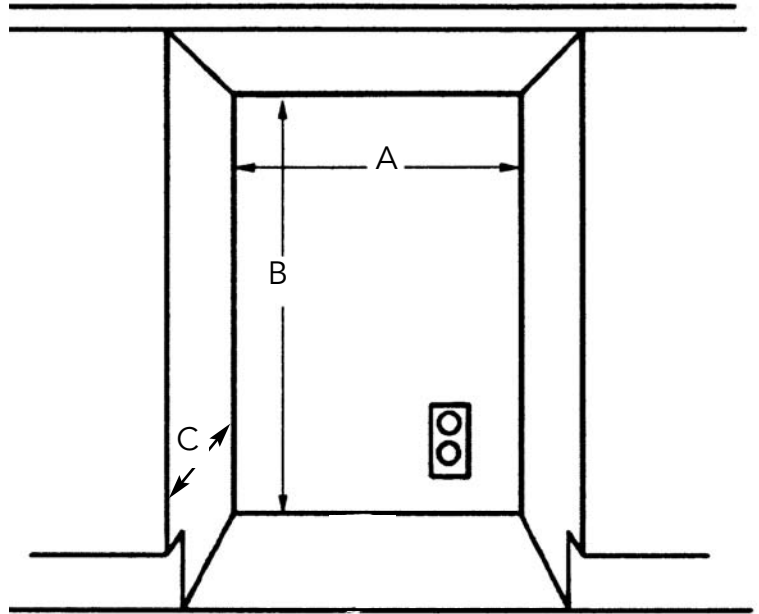

# SPECIFICATIONS/DIMENSIONS

## DESIGNER SERIES

### Basic Electric Data

- 115 VAC/60 Hz
- Maximum amps - 3.0
- Approximate shipping weight - 110 lbs (49.5 kg)

### Front View

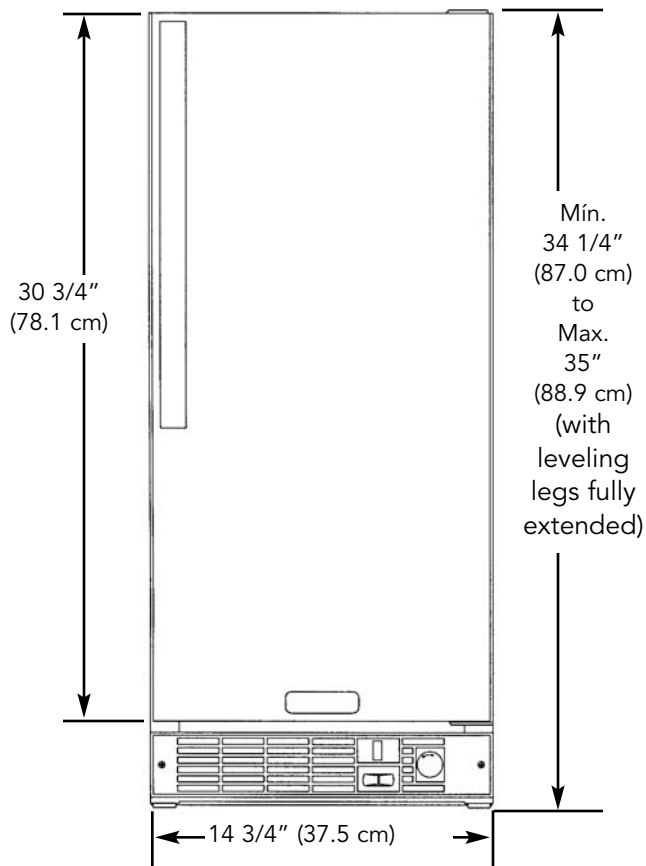

### Side View DUAR

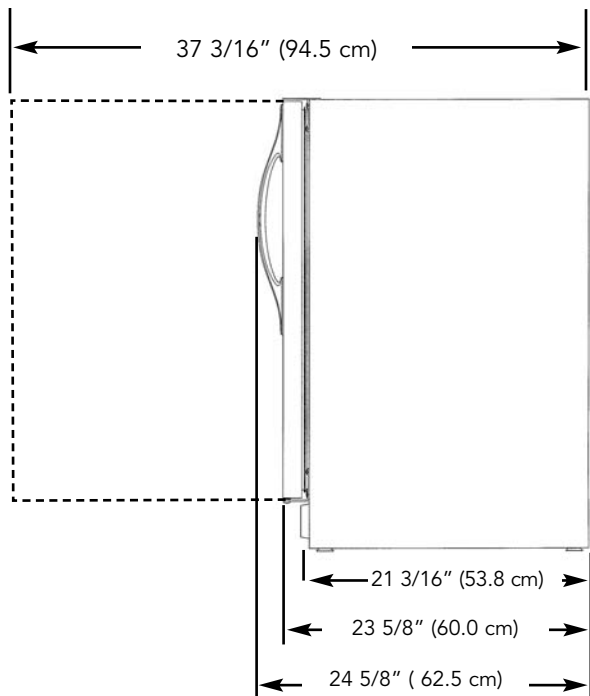

### Side View DFUR

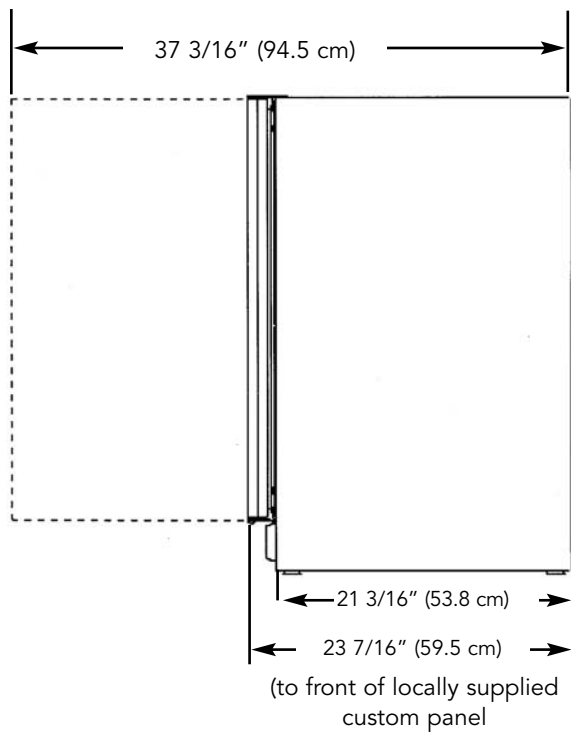

# CUSTOM WOOD FRAME INSTALLATION INSTRUCTIONS

## (DFUR Model)

Note: Weight of wood panel must not exceed 20 lbs.

### Wood Screws

1. A #8 pan head wood screw should be used to properly secure the wood frame. A total of 8 screws will be needed for a 3 1/2" (8.9 cm) kickplate or 7 screws for a 4" (10.2 cm) kickplate.
2. Only use pan head screws.
3. DO NOT select a screw that is longer than the wood thickness at the screw locations.
4. Use recommended pilot holes for the frame material. (See chart)

Working Material	Wood Screw Size #8
Hardwood	3/32 (0.24 cm)
Softwood	5/64 (0.20 cm)

### Assembling Door Hinge Brackets

(Disregard if hinge brackets are already attached)

1. Attach the top and bottom door hinge brackets to the door with the #10-32 machine screws and a 1/8" allen head driver as shown in Figure 1 below.
2. Press in the shoulder bushings to the top and bottom door hinge brackets. Make certain that the shoulder is to the outside of the door as shown in Figure 1 below.
3. Test fit the door to the unit to make certain door will hang correctly. The door is hung correctly when the top of the door is parallel to the top of the unit. (See Figure 2) Adjustments can be made by loosening the door hinge machine screws and moving the door hinge brackets on the door.
4. Tighten all four (4) machine screws after adjustments have been made.
5. Remove the door from the unit by removing the units top hinge set screw and angling the door off of the bottom hinge pin.

Figure 1

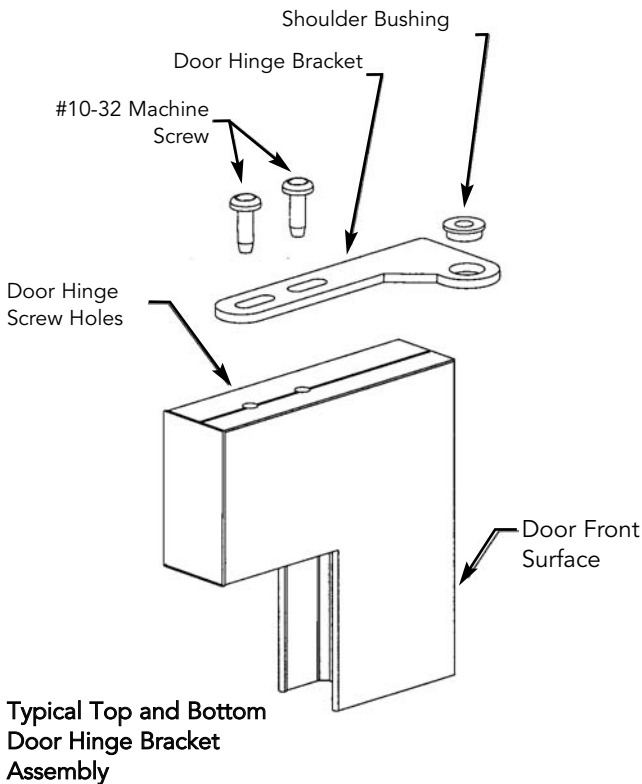
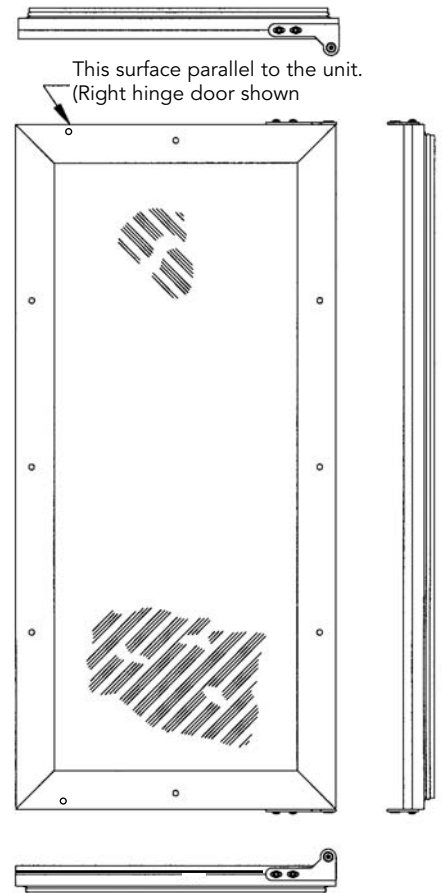
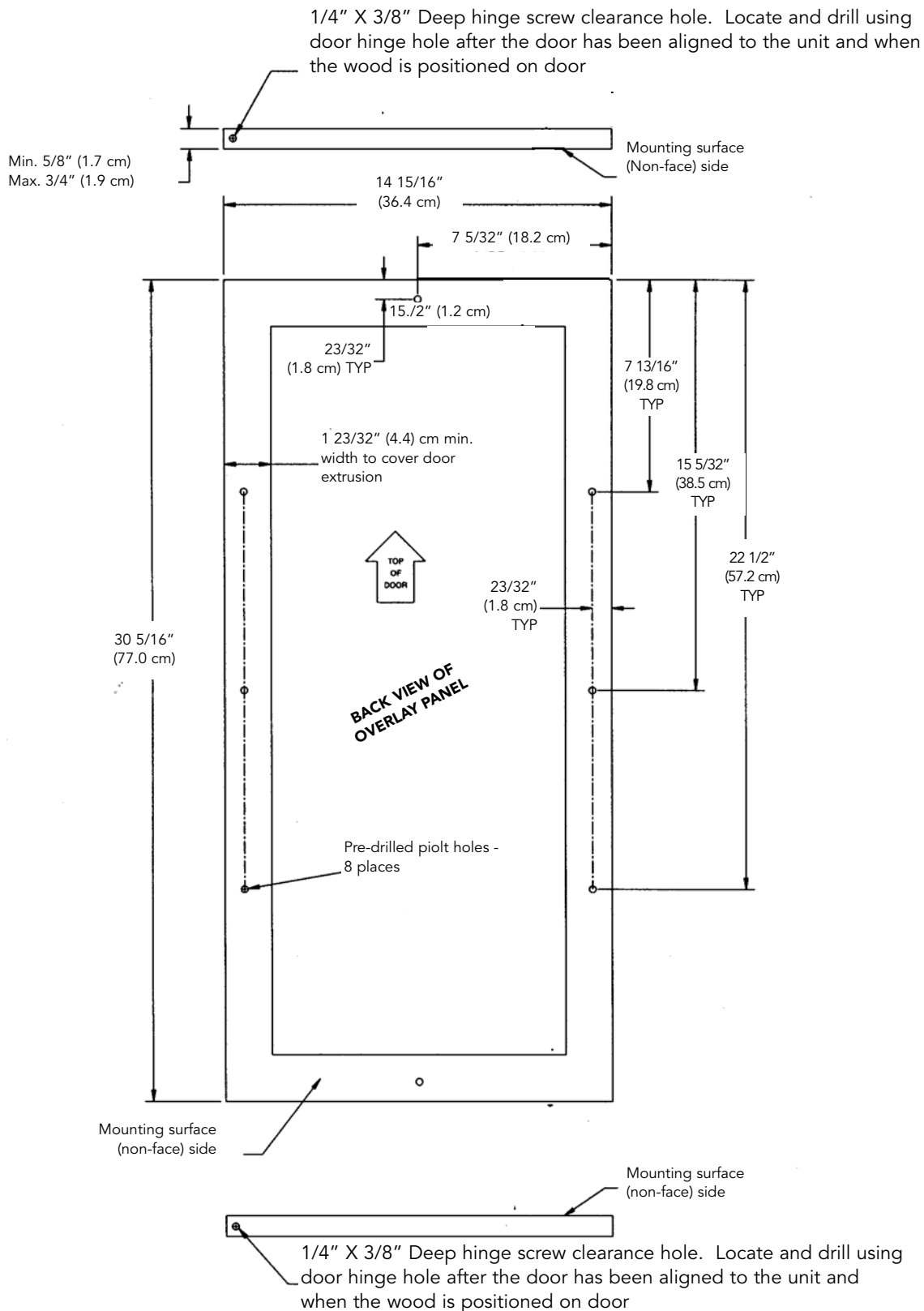

Figure 2



## Selecting and Preparing the Wood Frame - DFUR Model

### FOR A 3-1/2" TOE KICK (COVERS THE ENTIRE DOOR EXTRUSION)



## OPTIONAL FOR 4" TOE KICK TO MATCH EXISTING CABINETRY TOE KICK HEIGHT

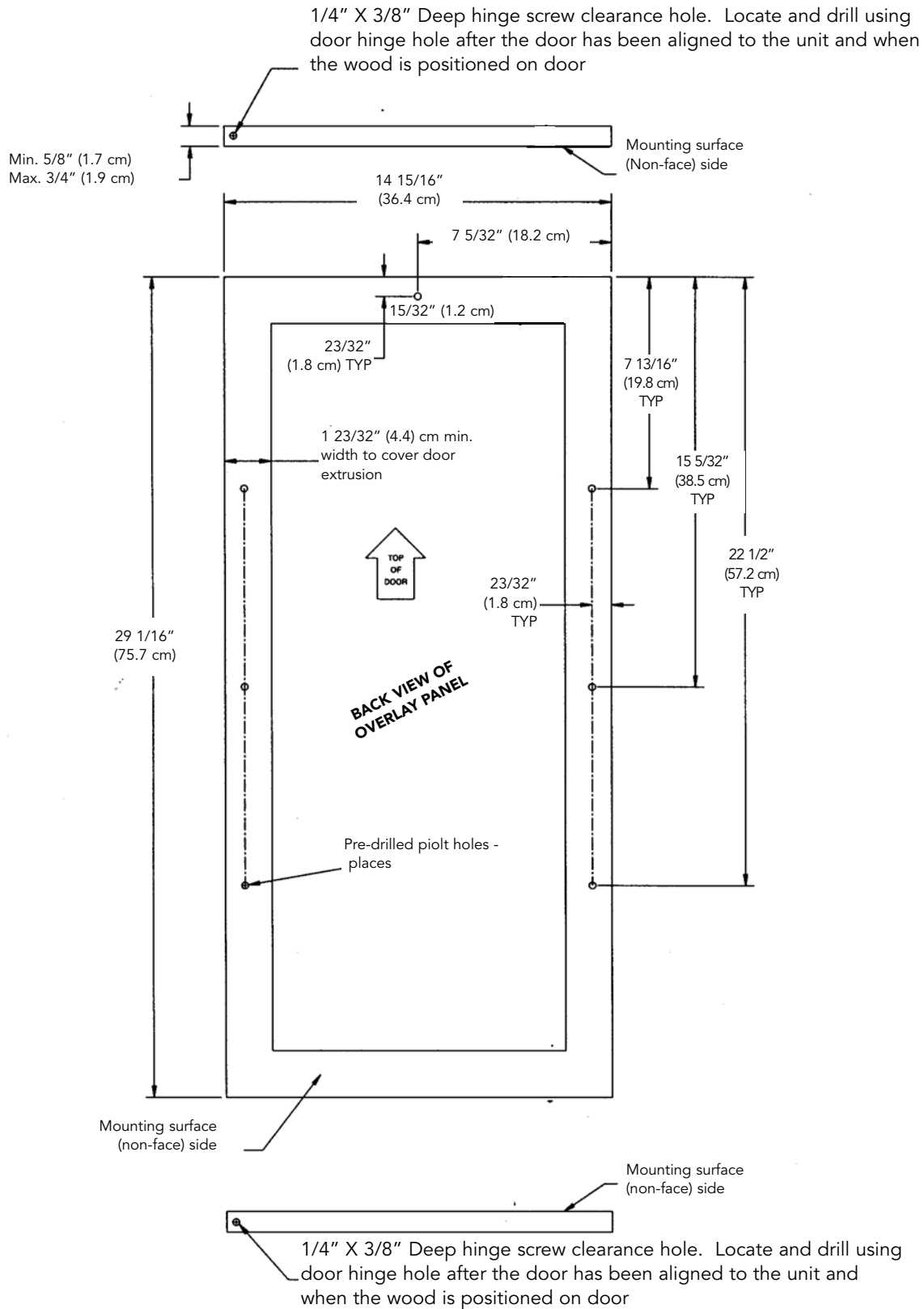

## Attaching the Wood Frame to the Door - DFUR Models

1. If the door is attached to the unit, remove by unscrewing the top allen head set screw at the top hinge. Remove the door by angling the door off of the bottom hinge pin.
2. Peel back the door gasket to expose the screw holes.
3. Set the wood frame flush to the front of the door in the desired location. Clamp the wood frame to the door if necessary.
4. Insert the wood screws through the back of the door into the pilot holes in the wood frame and tighten.
5. Reinstall the door gasket by pressing into the door channel.
6. Install the door to the unit. Use the supplied plastic washer as shown in the figure below.
7. Realigning the door may be necessary. Any final door adjustments can be made using a 1/8" allen head driver to adjust the door's hinges. (See figure below)
8. Attach the door light striker plate as shown using the 5/16" hex or phillips head screws provided. Make certain the light is able to turn on and off when the door is opened and closed.
9. Attach the door to the unit by reversing step number 1 above.

### Hinge Hardware Installation Details

