

UNDERCOUNTER CABINET CUTOUT

A	24" (61.0 cm)*
B	Min. 34 1/2" (87.6 cm) Max. 35 1/8" (89.2 cm)
C	24" (61.0 cm)

*24" width for cabinet only. 24 1/4" (61.6 cm) need for cabinet and door width clearance if door is recessed between cabinets.

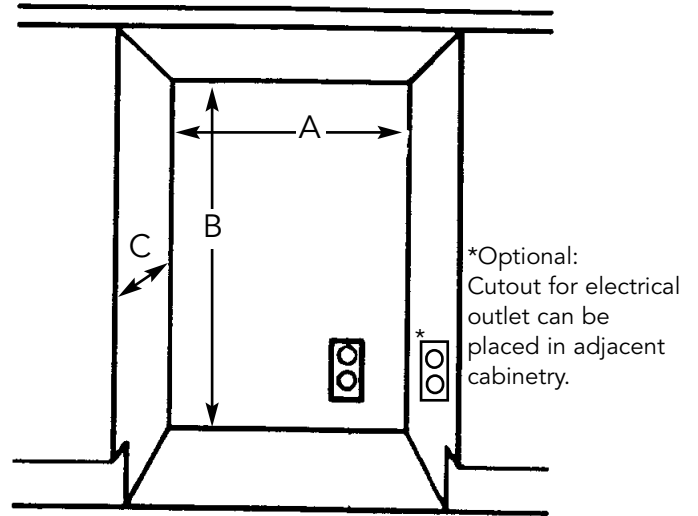

SPECIFICATIONS/DIMENSIONS PROFESSIONAL SERIES

Basic Electric Data

- 115 VAC/60 Hz
- Maximum amps - 3.3
- Approximate Shipping Weight - 140 lbs. (63.2 kg)

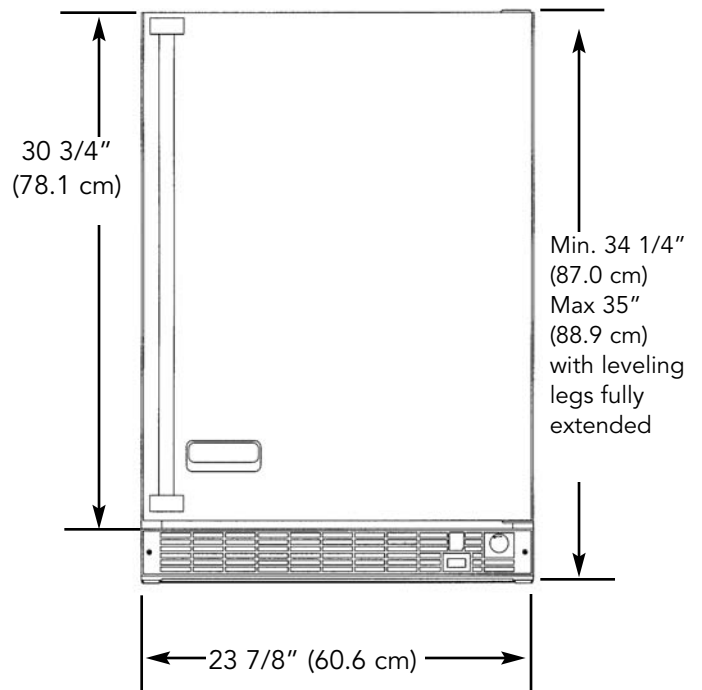
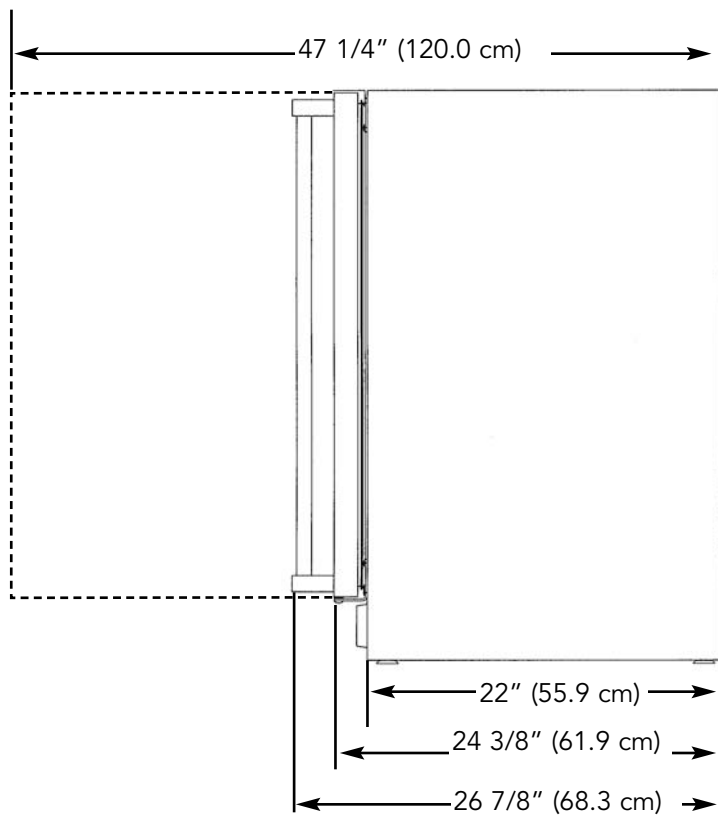

SPECIFICATIONS/DIMENSIONS

DESIGNER SERIES

Basic Electric Data

- 115 VAC/60 Hz
- Maximum amps - 3.3
- Approximate shipping weight - 140 lbs (63.2 kg)

Front View

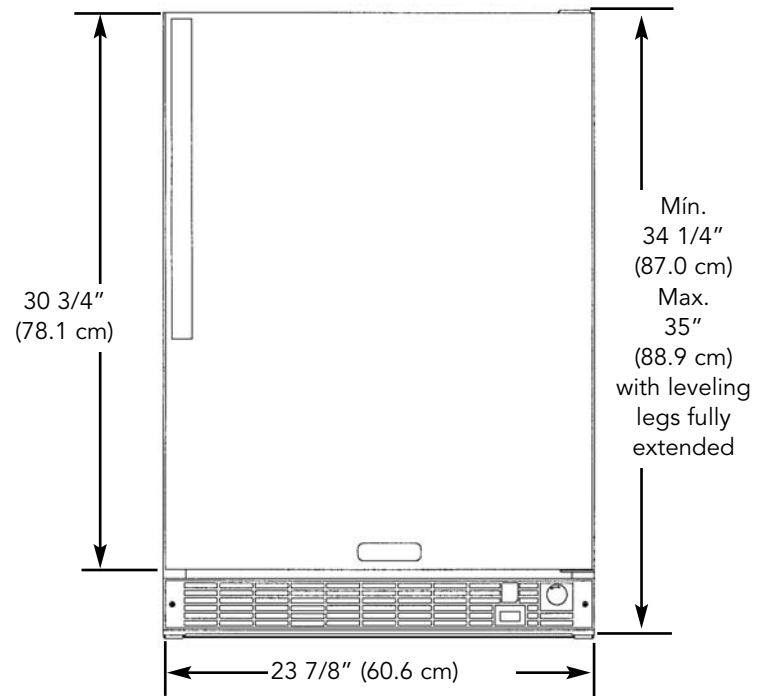

Side View

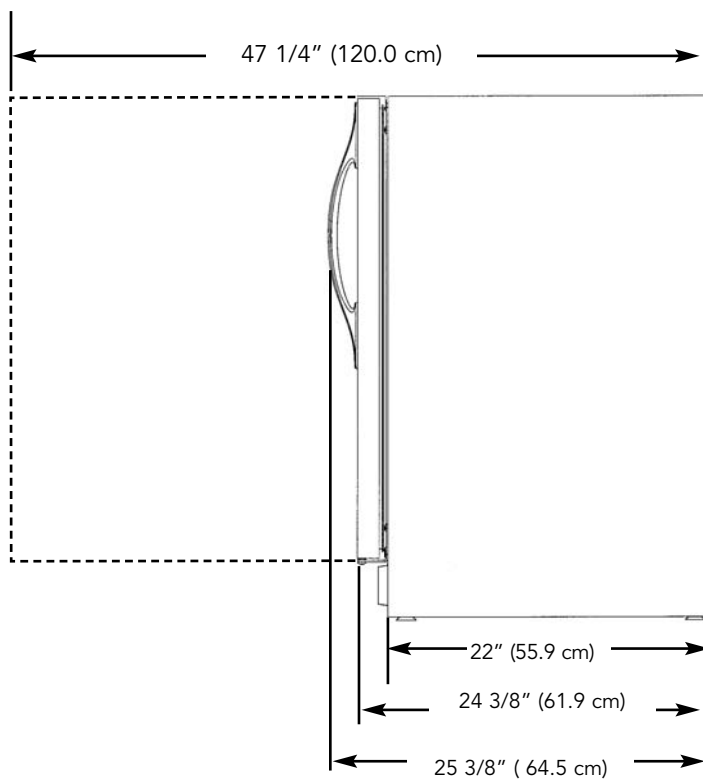

SELECTING AND PREPARING THE OVERLAY PANEL

FOR A 3-1/2" TOE KICK
(COVERS THE ENTIRE DOOR EXTRUSION)

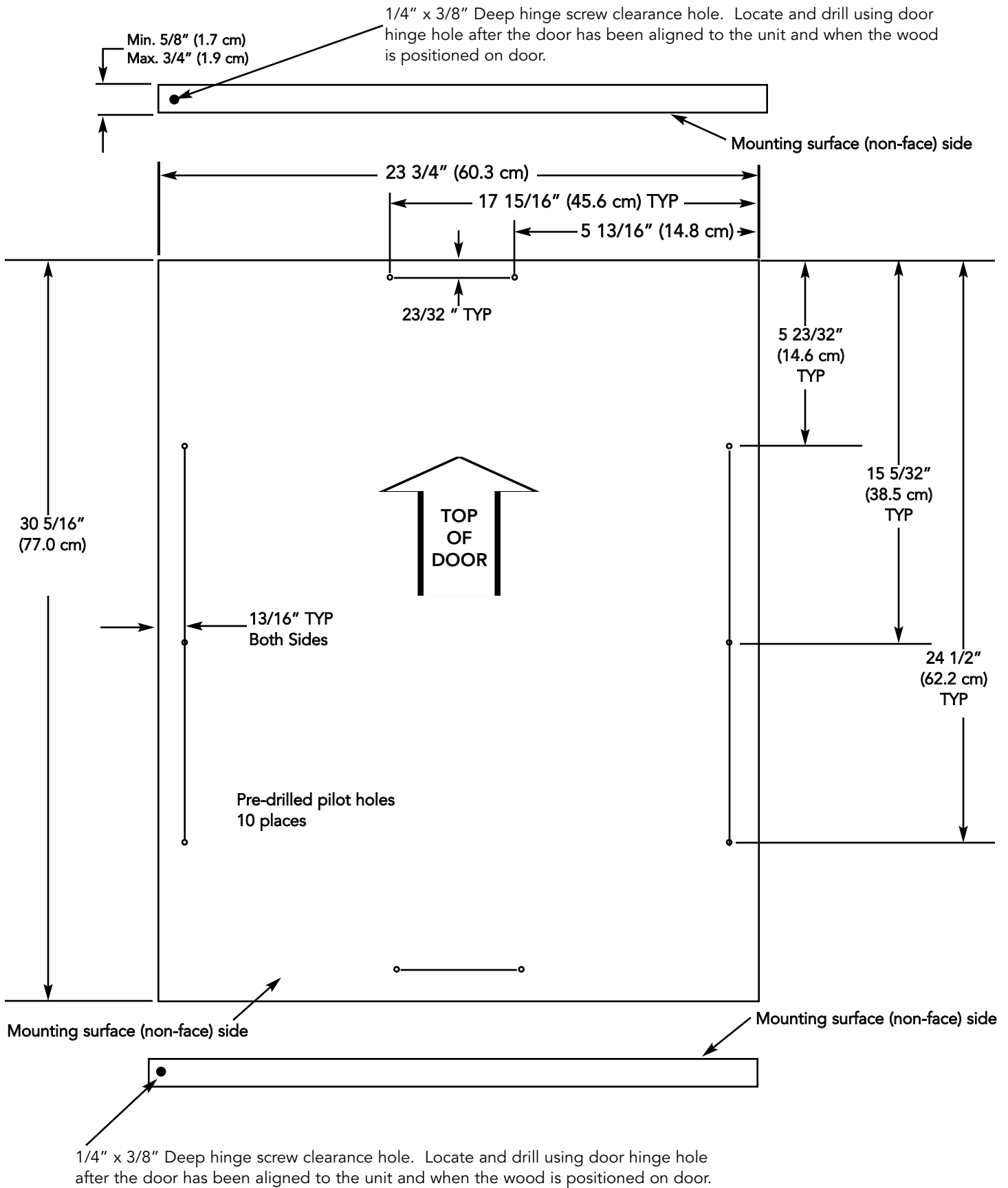

**OPTIONAL FOR 4" TOE KICK
TO MATCH EXISTING CABINETRY TOE KICK HEIGHT**

