

Viking Installation Guide



Freestanding Bottom-Mount/
French Door Bottom-Mount
Refrigerator/Freezer

Viking Range Corporation
111 Front Street
Greenwood, Mississippi 38930 USA

GENERAL INFORMATION

IMPORTANT - PLEASE READ AND FOLLOW

Make sure that incoming voltage is the same as unit rating. An electric rating plate specifying voltage, frequency, and amperage is attached to the product.

To reduce the risk of fire, electric shock, or injury to persons, installation work and electrical wiring must be done by qualified people in accordance with all applicable codes and standards, including fire-rated construction.

The installer should leave these instructions with the consumer who should retain them for local inspector's use and for future reference.

IMPORTANT SAFETY INSTRUCTIONS



Your safety and the safety of others is very important.

We have provided many important safety messages in this manual and on your appliance. Always read and obey all safety messages.



This is the safety alert symbol. This symbol alerts you to hazards that can kill or hurt you and others. All safety messages will be preceded by the safety alert symbol and the word "DANGER", "WARNING" or "CAUTION".

These words mean:

 DANGER	Immediate hazards which WILL result in severe personal injury or death
 WARNING	Hazards or unsafe practices which COULD result in severe personal injury or death.
 CAUTION	Hazards or unsafe practices which COULD result in minor personal injury or property damage.

All safety messages will identify the hazard, tell you how to reduce the chance of injury, and tell you what can happen if the instructions are not followed.

WARNING

To reduce the risk of fire, electric shock, serious injury or death when using your refrigerator, follow these basic precautions, including the following:

- Read all instructions before using the refrigerator.
- Observe all local codes and ordinances. Install refrigerator according to Installation Instructions. All connections for water, electrical power and grounding must comply with local codes and be made by licensed personnel when required.
- Do not modify plug on power cord. If plug does not fit electrical outlet, have proper outlet installed by a qualified technician. Replace worn power cords and/or loose plugs.
- Do not ground to a gas line or cold-water pipe.
- Do not remove warning tag from power cord
- Refrigerator is designed to operate on a separate 115 volt, 15 amp., 60 cycle line.
- Do not tamper with refrigerator controls.
- Do not service or replace any part of refrigerator unless specifically recommended in Use & Care or Installation Instructions. Do not attempt service if instructions are not understood or if they are beyond personal skill level.
- Always disconnect refrigerator from electrical supply before attempting to change light bulbs, clean, or service the refrigerator. Disconnect the power cord by grasping the plug, not the cord.
- Always read and follow manufacturer's storage and ideal environment instructions for items being stored in refrigerator.
- Never allow children to operate, play with, crawl inside or stand on any part the refrigerator.
- Never clean refrigerator parts with flammable fluids. The fumes can create a fire hazard or explosion.
- Clean up spills or water leakage associated with water installation.
- Keep your refrigerator in good condition. Bumping or dropping refrigerator can damage refrigerator or cause refrigerator to malfunction or leak. If damage occurs, have refrigerator checked by qualified service technician.

-SAVE THESE INSTRUCTIONS-

! DANGER
Risk of Child Entrapment
BEFORE YOU THROW AWAY YOUR OLD REFRIGERATOR OR FREEZER:

- Take off the doors.
- Leave the shelves in place so that children may not easily climb inside.

IMPORTANT: Child entrapment and suffocation are not problems of the past. Junked or abandoned refrigerators are still dangerous... even if they will sit for "just a few days."

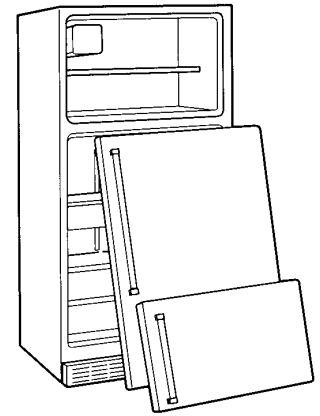

! WARNING

ELECTRICAL SHOCK HAZARD
 Plug into a grounded 3-prong outlet.
DO NOT remove ground plug.
DO NOT use an adapter.
DO NOT use an extension cord.
 Failure to follow these instructions could result in fire or electrical shock.

Power cord with 3-prong grounding plug

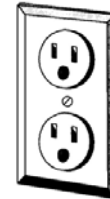
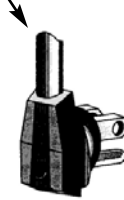

Grounding-type wall receptacle

It is the customer's responsibility to:

- contact a qualified electrical installer.
- assure that the electrical installation is adequate and in conformance with the National Electrical Code, ANSI/NFPA 70-latest edition or Canadian Electrical Code C22.1-1998 and C22.2 No. 0-M91 (or latest edition), and all local codes and ordinances. (115 volt, 60-Hz, 15 amp, fused, electrical supply is required. It is required that a separate circuit serving only this appliance be provided. This appliance is equipped with a power supply cord having a 3-prong grounding plug. To minimize possible shock hazard, the cord must be plugged into a mating 3-prong, grounding-type wall receptacle. If a 2-prong receptacle is encountered, the customer must contact a qualified electrical installer to have it replaced with a properly grounded 3-prong receptacle. **Do not use an extension cord or adapter plug.**)

BASIC SPECIFICATIONS AND DIMENSIONS

Freestanding Bottom Mount/French Door Bottom Mount

DESCRIPTION	VC/DDBF/VC/DDFF	
Overall Width	35 5/8" (90.5 cm)	
	Addition of side panels:	35 7/8" (91.1 cm)
Overall Height from Bottom	70 1/8" (178.1 cm)	
	Addition of tops/grilles:	71 7/8" (182.6 cm)
Overall Depth from Rear	To front of door:	26 3/4" (67.9 cm)
Cutout Width	36" (91.4 cm)	
Cutout Height	70 1/2" (179.0 cm)	
	Addition of tops/grilles	72" (182.9 cm)
Cutout Depth	24" (61.0 cm)	
Electrical Requirements	115 volt, 60 Hz, 15 amp dedicated circuit; 3-wire cord with grounded 3-prong plug attached to product.	
Maximum Amp Usage	7.9 amps	
Inlet Water Requirements	1/4" copper tubing inlet waterline; minimum 35 psi; maximum 100 psi	
Overall Interior Capacities	<u>Bottom Mount</u>	<u>French Door Bottom Mount</u>
•Refrigerator	14.4 cu. ft. (407 liters)	14.1 cu. ft. (399 liters)
•Freezer	5.5 cu. ft. (156 liters)	5.5 cu. ft. (156 liters)
•Total Capacity	19.9 cu. ft. (563 liters)	19.6 cu. ft. (555 liters)
Approximate Shipping Weight	327 lbs. (148.7 kg)	

**When installing into a cutout, the edge of the door must be 2 7/8" (7.3 cm) from the adjacent countertop cabinet.*

INSTALLATION

Your refrigerator was packed carefully for shipment. Remove and discard all packaging and tape. Do not remove the model/serial number label.

Location

- Do not install refrigerator near oven, radiator or other heat source. If not possible, shield refrigerator with cabinet material.
- Do not install where the temperature falls below 55°F (13°C) or rises above 110°F (43°C). Malfunction may occur at these temperatures.
- Refrigerator is designed for indoor household application only.

Measuring the Opening

When installing your refrigerator, measure carefully. Allow 1/2" (1.3 cm) space at top and 1/2" (1.3 cm) behind the machine compartment cover (located in the rear) for proper air circulation. Sub-flooring or floor coverings (i.e. carpet, tile, wood floors, rugs) may make your opening smaller than anticipated. Some clearance may be gained by using the leveling procedure under "LEVELING".

Transporting Your Refrigerator

- NEVER** transport refrigerator on its side. If an upright position is not possible, lay refrigerator on its back. Allow refrigerator to sit upright for approximately 30 minutes before plugging it in to assure oil returns to the compressor. Plugging the refrigerator in immediately may cause damage to internal parts.
- Use an appliance dolly when moving refrigerator. **ALWAYS** truck refrigerator from its side or back - **NEVER** from its front.
- Protect outside finish of refrigerator during transport by wrapping cabinet in blankets or inserting padding between the refrigerator and dolly.
- Secure refrigerator to dolly firmly with straps or bungee cords. Thread straps through handles when possible. Do not overtighten. Overtightening restraints may dent or damage outside finish.

Door and Drawer Removal

Some installations require door/drawer removal to transport the refrigerator to its final location.

<p>⚠ DANGER</p> <p>To avoid electrical shock which can cause severe personal injury or death, observe the following:</p> <ul style="list-style-type: none">•Disconnect power to refrigerator before removing doors or drawer. Connect power only after replacing doors or drawer.•Green ground wire must be attached to top hinge while performing door removal and replacement.•Tape decorative panels (select models) securely into place before removing door handles.	<p>⚠ CAUTION</p> <p>To avoid damage to walls and flooring observe the following:</p> <ul style="list-style-type: none">•Protect vinyl or other flooring with cardboard, rugs or other protective material, prior to moving refrigerator.•Do Not adjust refrigerator to be any shorter than 68 1/2" tall (minus hinge and cap). Doing so may damage underside components.
--	---

Bottom Mount Door Removal

1. Unplug power cord from power source.
2. Remove toe grille.
3. Remove top hinge cover from refrigerator door by removing Phillips screw and retain screw and cover for later use.
4. Unscrew 5/16" hex head screws from top hinge to remove hinge and retain all screws for later use.
5. Lift refrigerator door from center hinge pin.
6. Remove plastic sleeve, if present.
7. See page 6 for drawer removal instructions

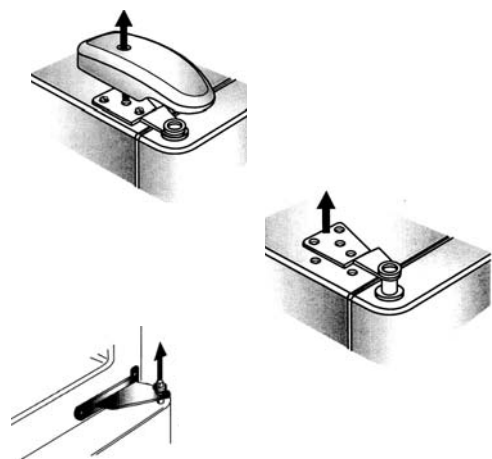

INSTALLATION

French-Door Bottom Mount Door Removal

1. Unplug power cord from power source.
2. Remove toe grille.
3. Remove top hinge covers from refrigerator doors by removing Phillips screw and retain screw and cover for later use.
4. Unscrew 5/16" hex head screws from top hinge to remove hinge and retain all screws for later use.
5. Lift right side refrigerator door from center hinge pin. Remove door closure from center hinge pin on the right side and retain for later use.
6. Disconnect wire harness on top of left side refrigerator door top hinge. Release two-pin connector by pressing junction point with a flat blade screwdriver or fingernail. Green ground wire remains attached to the hinge.

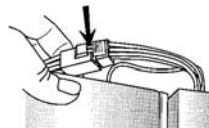
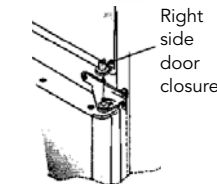
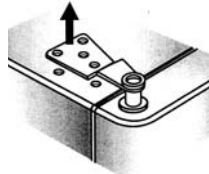
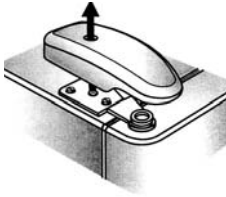

7. Unscrew 5/16" hex head screws from top hinge to remove hinge and retain all screws for later use. Lift left side refrigerator door, along with top hinge, from center hinge pin.
8. Remove phillips screws to remove right and left hinges and retain all screws for later use.

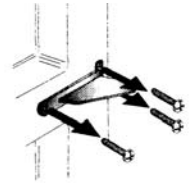

Pullout Freezer Drawer Removal

DANGER

To prevent accidental child entrapment or suffocation risk, do not remove the divider in the top freezer basket.

1. Pull drawer open to full extension.
2. Tilt the lower basket forward and lift to remove.
3. Lift top of drawer front to unhook the drawer from the slides. Lift door front out to remove.

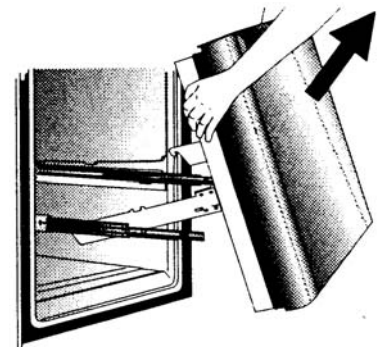

CAUTION

To avoid possible injury, product, or property damage, you will need two people to perform the following instructions.

INSTALLATION

Pullout Freezer Drawer Reinstallation

1. Pull both rails out to full extension.
2. While supporting door front, hook supports into slots located on inside of each slide.
3. Lower door front into final position.
4. Place the basket cradles back onto the drawer slides.
5. Tilt the lower basket front down and set it down into the basket cradles.

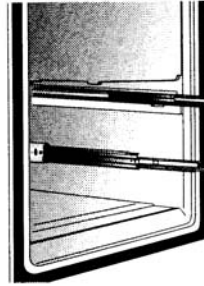

NOTE: All four drawer bracket supports must be in the proper slots for the drawer to function properly.

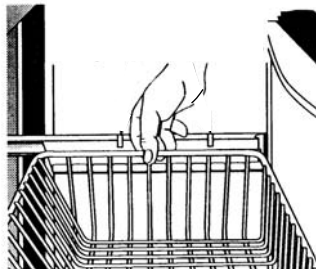
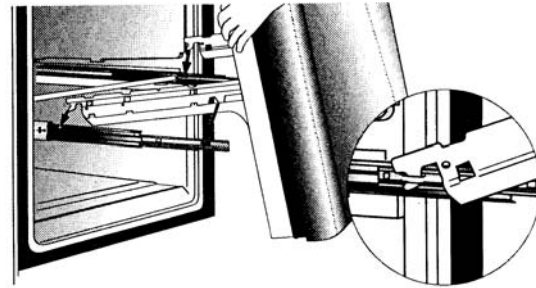

Bottom Mount Door Reinstallation

Install hinge assemblies

1. Install top hinge loosely with 5/16" hex head screws.
2. Install center hinge with phillips screws.
3. Place hinge side of refrigerator door on center hinge pin.
4. While holding refrigerator door upright, tighten down top hinge with 5/16" hex head driver and replace hinge cover.

French-Door Bottom Mount Door Reinstallation

1. Install hinge assemblies. Install center hinge with phillips screws.
2. Place hinge side of refrigerator door on center hinge pin. Install top hinge with 5/16" hex head screws.
3. While holding refrigerator door upright, tighten down top hinge with 5/16" hex head driver.
4. Reconnect two-pin connector.
5. Replace top hinge covers.

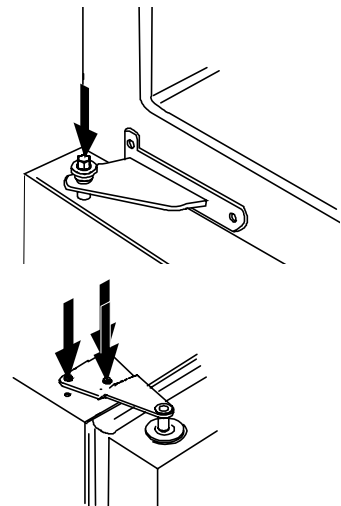

INSTALLATION

Opening and Closing the Refrigerator Doors - French-Door Bottom Mount Models

⚠ WARNING

To avoid electrical shock which can cause severe personal injury or death, **DO NOT** attempt to remove the hinged seal from the fresh food section.

Your new refrigerator is uniquely designed with two refrigerator doors. Either door can be opened or closed independently of one another. There is a vertically-hinged section on the left fresh food door. When the left door is closed, the hinged section automatically forms a seal between the two doors when both doors are closed. When the left door is opened, the hinged seal automatically folds inward so that it is out of the way.

⚠ CAUTION

To avoid possible product damage, **ALWAYS** verify that the hinged seal is folded against the edge of the door prior to closing.

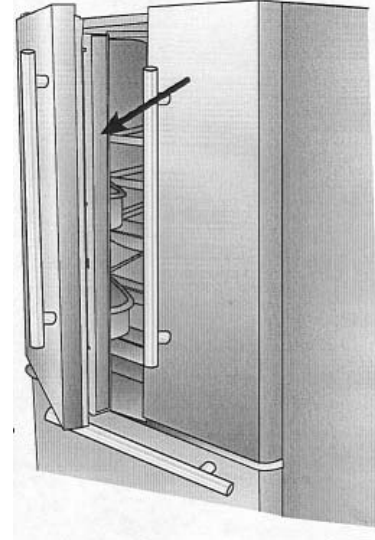

Connecting the Water Supply

⚠ WARNING

To reduce the risk of injury or death, follow basic precautions including the following:

- Do not attempt installation if instructions are not understood or if they are beyond personal skill level.
- Do not service ice maker
- Observe all local codes and ordinances.
- Water damage due to an improper water connection may cause mold/mildew growth. Clean up spills or leakage immediately.

Materials Needed

- 1/4" outer diameter flexible copper tubing
- Shut-off valve (requires a 1/4" hole to be drilled into water supply line before valve attachment)
- (2) Adjustable wrenches
- 1/4" hex nut driver

⚠ CAUTION

To avoid property damage or possible injury, follow basic precautions, including the following:

- Consult a plumber to connect 1/4" O.D. copper tubing to household plumbing to assure compliance with local codes and ordinances.
- Confirm water pressure to water valve is between 35 and 100 pounds per square inch, 20 pounds per square inch without a filter.
- Do not use a self-piercing, or 3/16" saddle valve. Both reduce water flow, can become clogged over time, and may cause leaks if repair is attempted.
- Tighten nuts by hand to prevent cross threading. Finish tightening nuts with pliers and wrenches. **DO NOT** overtighten.
- Wait two to three hours before placing refrigerator into final position to check and correct any water leaks. Recheck for leaks after 24 hours.
- Verify the copper tubing under the sleeve is smooth and free from defects. Do not reuse an old sleeve

NOTE:

- Use copper tubing only for installation. Plastic is less durable and can cause damage.
- Add 8 feet to tubing length needed to reach water supply for creation of service loop.

INSTALLATION

Connecting the Water Supply

1. Create service loop with copper tubing (minimum 2 feet diameter). Avoid kinks in the copper tubing when bending the service loop. Do not use plastic tubing. See figure 1
2. Remove plastic cap from water valve inlet port. See figure 2.
3. Place brass nut (A) and sleeve (B) on copper tube end as illustrated. **Remember:** Do not use old sleeve. The nut and the sleeve are provided in the consumer literature packet. See figure 3
4. Place end of copper tubing into water valve inlet port. Shape tubing slightly. Do not kink - so that tubing feeds straight into inlet port. See figure 4.
5. Slide brass nut over sleeve and screw nut into inlet port. Place adjustable wrench on nut "1" attached to plastic waterline and maintain position. Using second adjustable wrench, turn the lower nut "2" counterclockwise and fully tighten the upper nut in place. **IMPORTANT:** Do not overtighten. Cross threading may occur. See figure 5
6. Pull on tubing to confirm connection is secure. Connect tubing to frame with tubing clamp (C) and turn on water supply . See figure 6. Check for leaks and correct if necessary. Continue to observe the water supply connection for two or three hours prior to moving the refrigerator to its permanent location.
7. Monitor water connection for 24 hours. Correct leaks, if necessary.

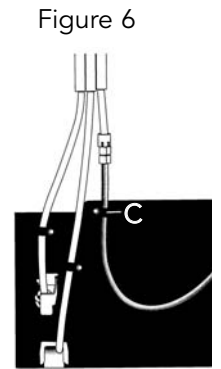
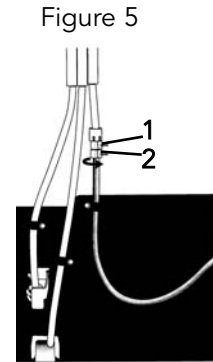
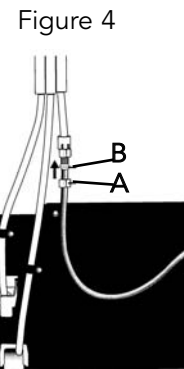
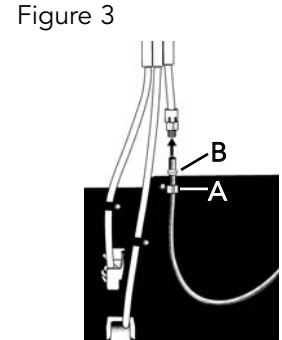
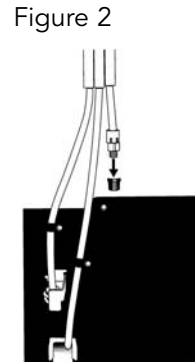
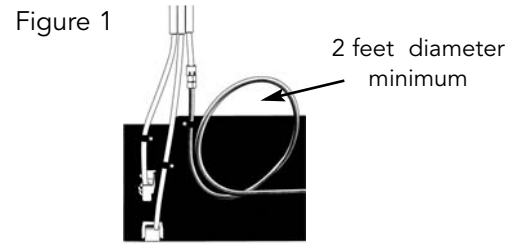

Leveling

Materials Needed

- 3/8" hex head driver
- Carpenter's level

CAUTION

To protect property and refrigerator from damage, observe the following:

- Protect vinyl or other flooring with cardboard, rugs, or other protective material.
- Do not use power tools when performing leveling procedure.

To enhance the appearance and maintain performance, the refrigerator should be level.

NOTE: Complete any required panel installation and/or water supply connection before leveling. Refrigerator should be in permanent location prior to leveling.

1. Remove toe grille. Grasp firmly and pull outward to unclip. See figure 7.
2. Using hex head driver, turn the front adjustment screws "A" on each side to raise or lower the front of the refrigerator.
3. Using the hex head driver, turn each of the adjustment screws "B" to raise or lower the rear of the refrigerator.
4. Using the carpenter's level, make sure front of refrigerator is 1/4" (.06 cm) or approximately 1/2 bubble higher than back of refrigerator and that the refrigerator is level from side to side.
5. Turn stabilizing legs "C" clockwise until firmly against floor.
6. Turn adjustment screws "A" counterclockwise to allow the full weight of the refrigerator to rest on the stabilizing legs.
7. Replace the toe grille. Align the toe grille mounting clips with the lower cabinet slots. Push the toe grille firmly until it snaps into place.

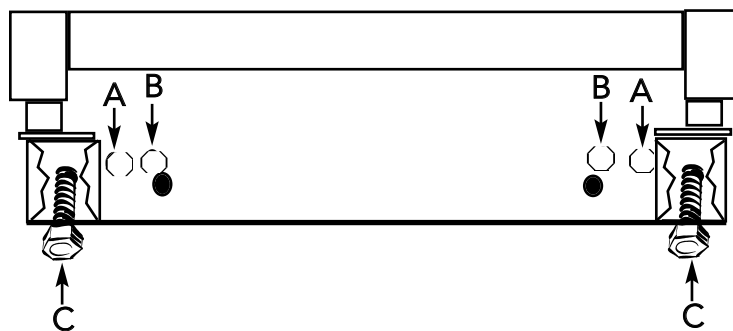
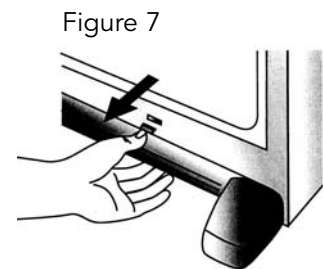

OPERATING SOUNDS

SOUND	POSSIBLE CAUSE	SOLUTION
Clicking	<ul style="list-style-type: none"> Freezer control clicks when starting or stopping compressor. Motorized device sounds like an electric clock and snaps in and out. 	<ul style="list-style-type: none"> Normal operation Normal operation
Air rushing or whirring	<ul style="list-style-type: none"> Freezer fan and condenser fan make this noise while operating. 	<ul style="list-style-type: none"> Normal operation
Gurgling or boiling sound	<ul style="list-style-type: none"> Evaporator and heat exchanger refrigerant makes this noise when flowing. 	<ul style="list-style-type: none"> Normal operation
Thumping	<ul style="list-style-type: none"> Ice cubes from ice maker (select models) drop into ice bucket. 	<ul style="list-style-type: none"> Normal operation
Vibrating noise	<ul style="list-style-type: none"> Compressor makes a pulsating sound while running. Refrigerator is not level. 	<ul style="list-style-type: none"> Normal operation See Installation Instructions for details on how to level your refrigerator.
Buzzing	<ul style="list-style-type: none"> Ice maker water valve hookup (select models) buzzes when ice maker fills with water. 	<ul style="list-style-type: none"> Normal operation
Humming	<ul style="list-style-type: none"> Ice maker is in the 'on' position without water connection. 	<ul style="list-style-type: none"> Stop sound by raising ice maker arm to OFF position
Hissing or popping	<ul style="list-style-type: none"> Compressor can make a high-pitched hum while operating. Defrost heater hisses, sizzles or pops when operational. 	<ul style="list-style-type: none"> Normal operation Normal operation

Troubleshooting

Problem	Possible Cause	What To Do
Freezer control and lights are on, but compressor is not operating	Refrigerator is in defrost mode.	Normal operation. Wait 40 minutes to see if compressor restarts.
Temperature-controlled drawers are too warm	Control settings are too low.	See use and care manual to adjust controls.
	Freezer controls are set too low.	See use and care manual to adjust controls.
	Drawer is improperly positioned.	See use and care manual to verify drawer positioning.
Refrigerator does not operate	Refrigerator is not plugged in.	Plug in refrigerator.
	Touch temperature controls are set to "OFF"	See use and care manual to set controls.
	Fuse is blown or circuit breaker needs to be reset.	Replace any blown fuses. Check circuit breaker and reset, if necessary.
	Power outage has occurred .	Call local power company to report outage.
Refrigerator still will not operate	Refrigerator is malfunctioning .	Unplug refrigerator and transfer food to another refrigerator. If another refrigerator is not available, place dry ice in freezer section to preserve food. Warranty does not cover food loss. Contact service for assistance.
Food temperature is too cold	Condenser coils are dirty.	Clean coils according to use and care manual.
	Refrigerator or freezer controls are set too high.	Properly adjust controls.
Food temperature is too warm	Door is not closing properly.	Check for internal obstructions that are keeping door from is too closing properly. Refrigerator is not level. See installation instructions for details on how to level your refrigerator. Check gaskets for proper seal, clean if necessary.
	Controls need to be adjusted.	See use and care manual to adjust your controls.
	Condenser coil is dirty.	Clean coils according to use and care manual.
	Rear air grille is blocked.	Check the positioning of food items in refrigerator to make sure grille is not blocked. Rear air grilles are located under produce drawers.
	Door has been opened frequently , or has been opened for long periods of time.	Reduce the time door is open. Organize food items efficiently to assure door is open for as short a time as possible.
	Food has recently been added.	Allow time for recently added food to reach refrigerator or freezer temperature.

Troubleshooting

Problem	Possible Cause	What To Do
Refrigerator has an odor	Odor producing foods should be covered. The interior needs cleaning.	Clean according to instructions in use and care
Water droplets form outside of door	Door gaskets are not sealing properly.	Clean gaskets according to instructions in use and care.
	Humidity levels are high.	Hot, humid weather can increase condensation.
	Controls require adjustment.	See use and care to adjust controls.
Water droplets form on inside of refrigerator	Humidity levels are high or door has been opened frequently.	Reduce time door is open. Organize food items efficiently to assure door is open for as short a time as possible.
Refrigerator or ice maker makes unfamiliar sounds or seems too loud	Normal operation	See operating sounds.
Temperature-controlled drawers do not close freely	Contents of drawer or positioning of items in compartments is obstructing drawer.	Reposition food and containers to avoid interference with the drawers.
	Drawer is not in proper position	See use and care instructions for proper placement.
	Drawer channels are dirty or need treatment.	Clean drawer channels with warm, soapy water. Rinse dry thoroughly. Apply thin layer of petroleum jelly to drawer channels.
Refrigerator runs too frequently	Door has been opened frequently or has been opened for long periods of time.	Reduce time door is open. Organize food items efficiently to assure door is open for shortest time.
	Humidity levels too high.	Normal operation
	Food has recently been added.	Allow time for added food to reach refrigerator or freezer temperature.
	Refrigerator is exposed to heat by environment or appliances nearby.	Evaluate refrigerator's environment. Refrigerator may need to be moved to run more efficiently.
	Condenser coils are dirty.	Clean coils according to instructions in use and care.
	Controls need to be adjusted.	See use and care manual to adjust controls.
	Door is not closing properly.	Check for internal obstructions that are keeping door from closing properly. Refrigerator is not level. See installation instructions for details on how to level your refrigerator. Check gaskets for proper seal, clean if necessary.
	Door gaskets are not sealing properly.	See use and care manual for cleaning instructions.
Ice and Water Ice maker is not producing ice.	Ice maker arm is up	Confirm ice maker arm is down. See Automatic Ice Maker instructions in use and care
	Water supply is not reaching water valve.	See Connecting the Water Supply instructions.
	Copper tubing has kinks	Turn off water supply and remove kinks. If kinks cannot be removed, replace tubing.
	Water pressure is too low	Low water pressure must be between 35 to 100 pounds per square inch to function properly. A minimum pressure of 35 pounds per square inches recommended for refrigerators with water filters.
	Check freezer temperature	See Temperature Controls in use and care manual to adjust controls. Freezer must be between 0° - 2° F (-18° to -17°C)/
	Ice bin is not installed properly	See Ice and Water instructions in use and care manual.
	Improper water valve was installed.	See Connecting the Water Supply instructions. Self-piercing and 3/16" saddle valves cause low water pressure and may clog the line over time.*
	Water filter indicator light is red	Water filter needs to be replaced.
Filter indicator sensor needs to be reset		See Filter Status Indicator Light in use and care manual.
Refrigerator is leaking water	Plastic tubing was used for water connection	The manufacturer recommends using copper tubing. Plastic is less durable and can cause leakage*.
	Improper water valve installed	Check water connection procedure in installation instructions. Self piercing and 3/16" saddle valves cause low water pressure and may clog the line over time.*

*Manufacturer is not responsible for property damage due to improper installation or water connection.

Troubleshooting

Problem	Possible Cause	What To Do
Ice forms in inlet tube to ice maker	Water pressure is low	Water pressure must be between 35 - 100 pounds per square inch. A minimum pressure of 35 pounds per square inch is recommended for refrigerators with water filters.
	Improper water valve installed.	Check water connection procedure in installation instructions. Self piercing and 3/16" saddle valves cause low water pressure and may clog the line over time.*
	Copper tubing has kinks	Turn off water supply and remove kinks. If kinks cannot be removed, replace tubing.
	Saddle valve is not open completely.	Open saddle valve completely.
	Freezer temperature is too high	Adjust freezer controls. Freezer is recommended to be approximately 0°F (-18°C)/
Water flow is slower than normal	Water pressure is low	Water pressure must be between 35 - 100 pounds per square inch. A minimum pressure of 35 pounds per square inch is recommended for refrigerators with water filters.
	Saddle valve is not open completely.	Open saddle valve completely.
	Improper water valve installed.	Check water connection procedure in installation instructions. Self piercing and 3/16" saddle valves cause low water pressure and may clog the line over time.*
	Copper tubing has kinks	Turn off water supply and remove kinks. If kinks cannot be removed, replace tubing.
	Water filter needs to be changed	Change water filter. See use and care manual.
Dispenser water is not cold	Refrigerator has been recently installed. Water supply in holding tank has been used.	Allow approximately 12 hours for water in holding tank to chill.
Water appears cloudy	Air or bubbles in water.	This is normal when first using the dispenser and will disappear with use.
Particles in water and/or ice cubes	Carbon dust from water filter cartridge	Initial water ejected through cartridge may contain harmless carbon dust flushed from cartridge. Will disappear after first few uses.
	Concentration of minerals in water will form particles when water becomes frozen and melts.	Particles are not harmful and naturally occur in water supplies.

*Manufacturer is not responsible for property damage due to improper installation or water connection.

WIRING DIAGRAM FREESTANDING BOTTOM MOUNT/ FRENCH DOOR BOTTOM MOUNT REFRIGERATOR/FREEZER

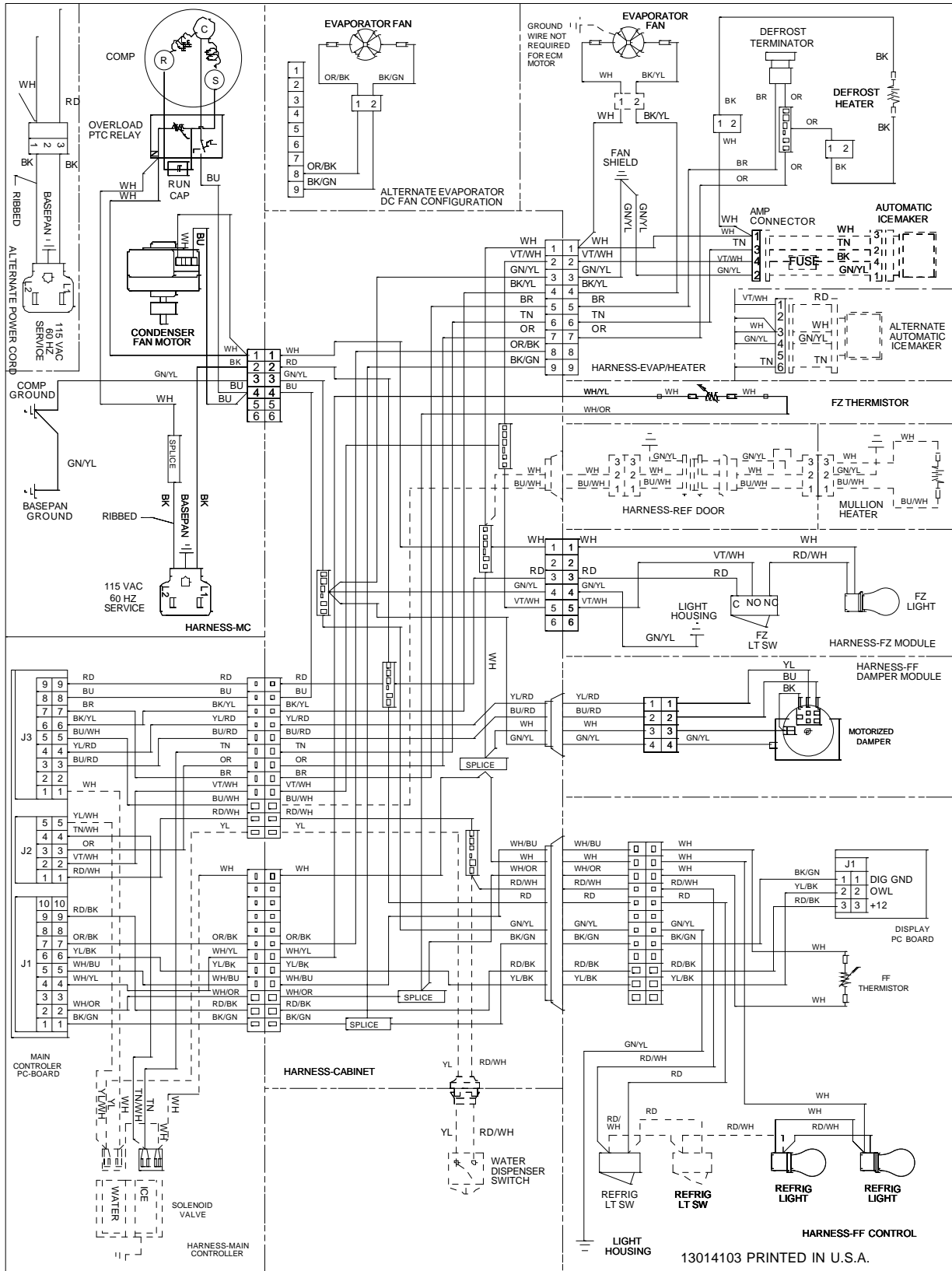

WARNING All electrical work must be performed by a qualified technician



VIKING RANGE CORPORATION
111 Front Street
Greenwood, Mississippi 38930 USA
(662) 455-1200

For product information
call 1-888-VIKING1 (845-4641)
or visit the Viking Web site at
vikingrange.com

Specifications subject to change without notice